

THIS MANUAL MAY NOT BE SOLD

# SHOP MANUAL

## HONDA

### S1

#### MANUAL TRANSMISSION MAINTENANCE AND REPAIR

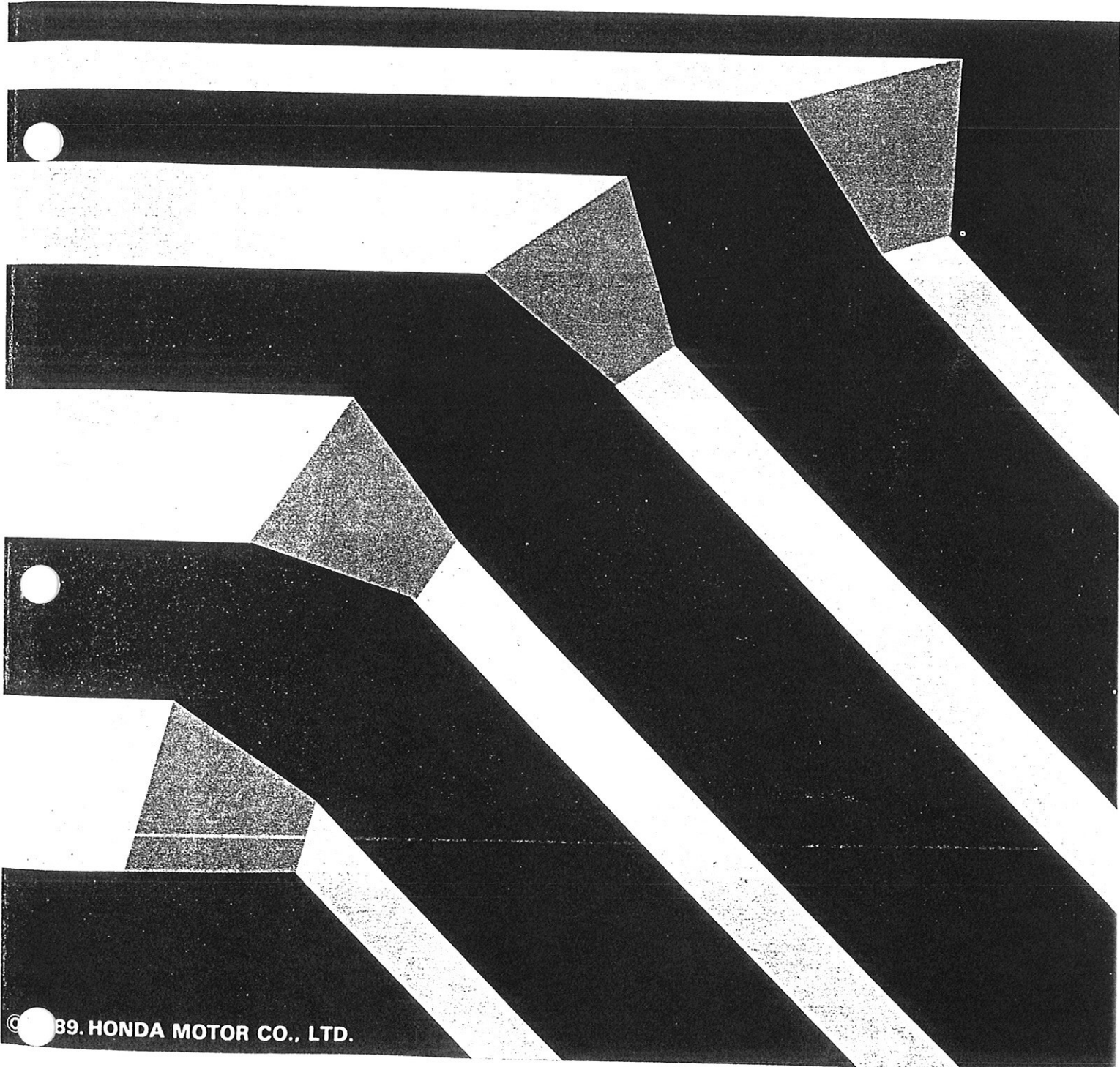

© 1989 HONDA MOTOR CO., LTD.



# INTRODUCTION

## How to Use This Manual

This manual contains information regarding repair procedures for the S1 type of Manual Transmission. For information regarding installation and removal of the transmission, and the shift mechanism, please consult the Chassis maintenance and repair manual for the vehicle concerned.

This manual is divided into 3 sections. The first page of each section is numbered with a black tab that lines up with one of the thumb index tabs on this page. You can quickly find the first page of each section without looking through a full table of contents.

Each section includes:

1. A table of contents, or an exploded view index showing:
  - Parts disassembly sequence.
  - Bolt torques and thread sizes.
  - Page references to descriptions in text.
2. Disassembly/assembly procedures and tools.
3. Inspection.
4. Repair.
5. Adjustments.

General Info

Transmission Overhaul

Differential

## Special Information

**▲ WARNING** Indicates a strong possibility of severe personal injury or loss of life if instructions are not followed.

**CAUTION:** Indicates a possibility of personal injury or equipment damage if instructions are not followed.

**NOTE:** Gives helpful information.

**CAUTION:** Detailed descriptions of *standard* workshop procedures, safety principles and service operations are not included. Please note that this manual does contain warnings and cautions against some specific service methods which could cause **PERSONAL INJURY**, or could damage a vehicle or make it unsafe. Please understand that these warnings cannot cover all conceivable ways in which service, whether or not recommended by Honda Motor, might be done, or of the possible hazardous consequences of each conceivable way, nor could Honda Motor investigate all such ways. Anyone using service procedures or tools, whether or not recommended by Honda Motor, *must satisfy himself thoroughly* that neither personal safety nor vehicle safety will be jeopardized.

All information contained in this manual is based on the latest product information available at the time of printing. We reserve the right to make changes at any time without notice. No part of this publication may be reproduced, stored in retrieval system, or transmitted, in any form by any means, electronic, mechanical, photocopying, recording, or otherwise, without the prior written permission of the publisher. This includes text, figures and tables.

HONDA MOTOR CO., LTD.  
Service Publication Office





## General Information

Preparation of Work .....	1-2
Symbol Marks .....	1-3

# General Information

## Preparation of Work

1. Work safely and give your work your undivided attention. Exchange signals as frequently as possible when a work involves two or more workers.
2. Prior to removing or disassembling parts, they must be inspected carefully to isolate the cause for which the service is called for. Observe all safety notes and precautions and follow the proper procedures as described in this manual.

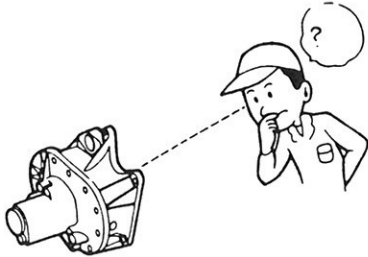

- Mark or place all removed parts in order in a parts rack so they can be placed back to their original places or parts from which they were removed or with which they were mated.
- Check each part for distortion, cracks, scratches, or other damages whenever it is removed.



3. Use special tool when use of such a tool is specified, or you may damage the parts or get injured.

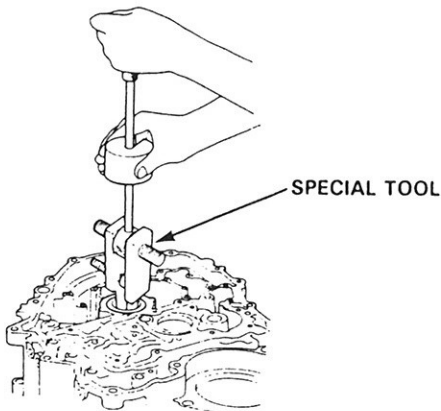

4. Parts must be assembled with the proper looseness or tightness according to the maintenance standards established.
5. When tightening bolts or nuts, begin on center or large diameter bolts and tighten them in crisscross pattern in two or more steps if necessary.

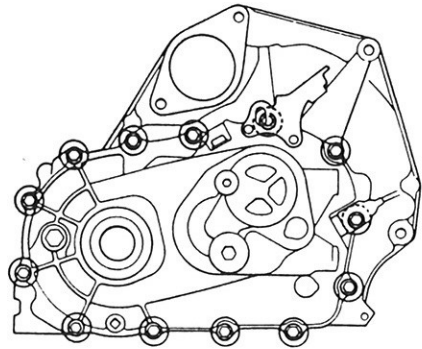

6. Use new packings, gaskets, O-rings and cotter pins whenever reassembling.

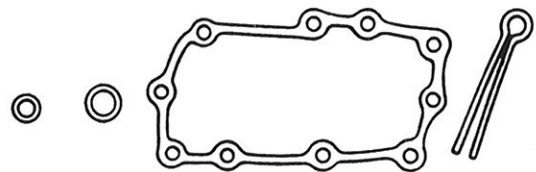

7. Use genuine HONDA parts and lubricants or those equivalent. When parts are to be reused, they must be inspected carefully to make sure they are not damaged or deteriorated and in good usable condition.
8. Coat or fill parts with specified grease. Clean all removed parts in or with solvent upon disassembly.

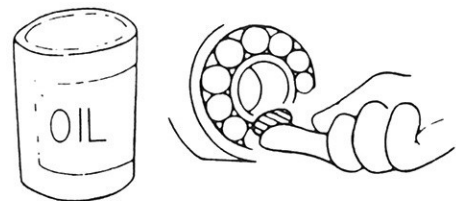

## Symbol Marks

The following symbols stand for:



: Apply engine oil.



: Apply grease.



## Transmission Overhaul

Service Specifications .....	2-2	Countershaft Bearing (Clutch Housing) Replacement.....	2-16
Special Tools .....	2-3	Mainshaft Bearing, Oil Seal (Clutch Housing) Replacement.....	2-17
Illustrated Index .....	2-4	Mainshaft Assembly Index .....	2-18
Transmission Housing Removal.....	2-6	Clearance Inspection.....	2-19
Reverse Shift Fork, 5th/Reverse Shift Piece Clearance Inspection.....	2-7	Disassembly .....	2-21
Reverse Shift Fork, Reverse Idler Gear Clearance Inspection.....	2-8	Inspection .....	2-22
Shift Arm, Shift Guide Clearance Inspection.....	2-9	Reassembly .....	2-23
Selector Arm, Interlock Clearance Inspection.....	2-9	Mainshaft Thrust Shim Adjustment .....	2-24
Shift Arm Holder Assembly Clearance Inspection.....	2-10	Countershaft Assembly Index .....	2-26
Removal.....	2-10	Clearance Inspection.....	2-27
Transmission Disassembly .....	2-11	Disassembly .....	2-28
Shift Arm, Shift Rod Guide Clearance Inspection.....	2-12	Inspection .....	2-29
Select Arm, Shift Rod Guide Clearance Inspection.....	2-12	Reassembly .....	2-30
Shift Arm Holder Assembly Disassembly/Reassembly .....	2-13	Synchro Ring, Gear Inspection .....	2-32
Shift Fork, 5th/Reverse Shift Piece and Shift Guide Clearance Inspection.....	2-14	Synchro Sleeve, Synchro Hub Inspection .....	2-33
Shift Fork, Synchro Sleeve Clearance Inspection.....	2-14	Installation .....	2-33
Shift Fork Shaft Assembly Disassembly/Reassembly .....	2-15	Transmission Reassembly .....	2-34

# Service Specifications

Unit of length: mm ( )

	MEASUREMENT	STANDARD (NEW)	SERVICE LIMIT
Transmission oil	Capacity ℓ (US qt, Imp qt)	2.2 (2.3, 1.9) after overhaul 2.1 (2.2, 1.8) at change	
Mainshaft	End play Diameter of ball bearing contact area, clutch housing side Diameter of 3rd gear contact area Diameter of ball bearing contact area, transmission housing side Runout	0.11 - 0.18 (0.004 - 0.007) 27.977 - 27.990 (1.1015 - 1.1020) 31.984 - 32.000 (1.2592 - 1.2598) 21.987 - 22.000 (0.8656 - 0.8661) below 0.02 (0.0008)	Adjust with a shim 27.930 (1.0996) 31.930 (1.2571) 21.940 (0.8638) 0.05 (0.0020)
Mainshaft 3rd gear and 4th gear	I.D. End play Thickness 3rd 4th	37.009 - 37.025 (1.4570 - 1.4577) 0.06 - 0.21 (0.003 - 0.008) 31.92 - 31.97 (1.2568 - 1.2587) 31.42 - 31.47 (1.237 - 1.239)	37.080 (1.4598) 0.30 (0.012) 31.85 (1.2539) 31.35 (1.234)
Mainshaft 5th gear	I.D. End play Thickness	37.009 - 37.025 (1.4570 - 1.4577) 0.06 - 0.21 (0.003 - 0.008) 29.42 - 29.47 (1.158 - 1.162)	37.080 (1.4598) 0.30 (0.012) 29.35 (1.156)
Countershaft	Diameter of needle bearing contact area Diameter of ball bearing contact area Diameter of low gear contact area Runout	33.000 - 33.015 (1.299 - 1.300) 24.987 - 25.000 (0.9837 - 0.9843) 36.984 - 37.000 (1.456 - 1.457) below 0.02 (0.0008)	32.950 (1.297) 24.940 (0.9819) 36.930 (1.454) 0.05 (0.0020)
Countershaft Low gear	I.D. End play, after tightening with specified torque	42.009 - 42.025 (1.654 - 1.655) 0.04 - 0.12 (0.0016 - 0.0047)	42.080 (1.657) Adjust with a shim
Countershaft 2nd gear	I.D. End play, after tightening with specified torque Thickness	47.009 - 47.025 (1.8507 - 1.8514) 0.05 - 0.12 (0.0020 - 0.0047) 32.42 - 32.47 (1.276 - 1.278)	47.080 (1.8535) Adjust with a collar 32.35 (1.274)
Spacer collar of countershaft 2nd gear	I.D. O.D. Length A B	34.995 - 35.005 (1.3778 - 1.3781) 41.989 - 42.000 (1.653 - 1.654) 32.56 - 32.58 (1.282 - 1.283) 32.59 - 32.61 (1.283 - 1.284)	35.015 (1.3785) 41.940 (1.651) — —
Spacer collar of mainshaft 4th gear and 5th gear	I.D. O.D. Length A B	25.002 - 25.012 (0.984 - 0.985) 31.989 - 32.000 (1.259 - 1.260) 57.95 - 58.05 (2.281 - 2.284) 27.03 - 27.08 (1.064 - 1.066)	25.060 (0.987) 31.940 (1.257) — —
Reverse idle gear	I.D. Gear-to-reverse shaft clearance	20.016 - 20.036 (0.788 - 0.789) 0.036 - 0.077 (0.001 - 0.003)	— 0.14 (0.006)
Synchro ring	Ring-to-gear clearance (ring pushed against gear)	0.85 - 1.10 (0.033 - 0.043)	0.40 (0.016)
Shift fork	Thickness of synchro sleeve contact area Fork-to-synchro sleeve clearance	7.40 - 7.50 (0.291 - 0.295) 0.45 - 0.65 (0.018 - 0.026)	— 1.00 (0.039)
Reverse shift fork	Groove width of reverse idle gear contact area Fork-to-reverse idler gear clearance "L" groove width at reverse gear side at 5th gear side Fork-to-5th/reverse shift shaft clearance at reverse gear side at 5th gear side	13.00 - 13.30 (0.512 - 0.524) 0.50 - 1.10 (0.020 - 0.043) 7.05 - 7.25 (0.278 - 0.285) 7.40 - 7.70 (0.291 - 0.303) 0.05 - 0.35 (0.002 - 0.014) 0.40 - 0.80 (0.016 - 0.031)	— 1.80 (0.071) — — 0.50 (0.020) 1.00 (0.039)
Shift rod guide	Groove width of shift arm contact area Shift rod guide-to-shift arm clearance	12.05 - 12.15 (0.474 - 0.478) 0.05 - 0.35 (0.002 - 0.014)	— 0.80 (0.031)
Shift guide	Groove width of shift arm contact area Shift rod guide-to-shift arm clearance I.D. Guide-to-shaft clearance Diameter of shift fork contact area Guide-to-shift fork clearance	8.10 - 8.20 (0.319 - 0.323) 0.10 - 0.30 (0.004 - 0.012) 14.000 - 14.068 (0.551 - 0.554) 0.011 - 0.092 (0.0004 - 0.0036) 11.90 - 12.00 (0.469 - 0.472) 0.20 - 0.50 (0.008 - 0.020)	— 0.60 (0.024) — 0.150 (0.0059) — 0.80 (0.032)
Selector arm	Diameter of shift rod guide contact area Arm-to-shift rod guide clearance Groove width of interlock contact area Arm-to-interlock clearance	11.90 - 12.00 (0.469 - 0.472) 0.05 - 0.25 (0.002 - 0.010) 10.05 - 10.15 (0.396 - 0.400) 0.05 - 0.25 (0.002 - 0.010)	— 0.50 (0.020) — 0.50 (0.020)



# Special Tools

## Special Tools

Ref. No.	Tool No.	Description	Qty	Remarks
①	07744-0010200	Pin Driver, 3.0 mm	1	
②	07744-0010400	Pin Driver, 5.0 mm	1	
③	07JAC-PH80000	Adjustable Bearing Remover Set	1	
③-1	07JAC-PH80100	Bearing Remover Attachment	(1)	} Component Tools
③-2	07JAC-PH80200	Remover Handle Assembly	(1)	
③-3	07741-0010201	Remover Weight	(1)	
④	07749-0010000	Outer Handle A	1	
⑤	07746-0010400	Outer Driver, 52 x 55 mm	1	
⑥	07746-0010200	Outer Driver, 37 x 40 mm	1	
⑦	07746-0041100	Pilot Driver, 28 x 12 mm	1	
⑧	07GAJ-PG20102	Mainshaft Clearance Inspection Tools Set	1	
⑧-1	07GAJ-PG20110	Mainshaft Holder	(1)	} Component Tools
⑧-2	07GAJ-PG20130	Mainshaft Base	(1)	
⑨	07979-PJ40001	Magnet Stand Base	1	
⑩	07746-0010300	Outer Driver, 42 x 47 mm	1	



①

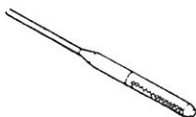

②

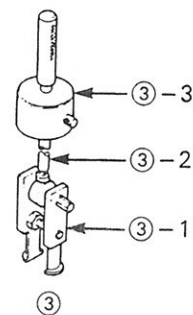

③

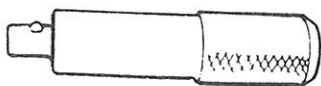

④

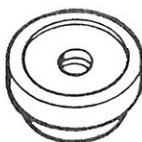

⑤

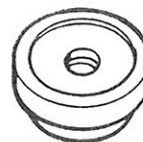

⑥



⑦

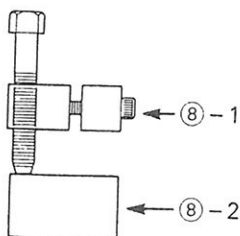

⑧

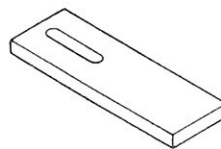

⑨

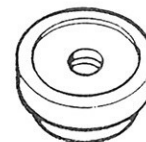

⑩

# Illustrated Index

 Prior to reassembling, clean all the parts in solvent, dry them and apply lubricant to any contact parts.

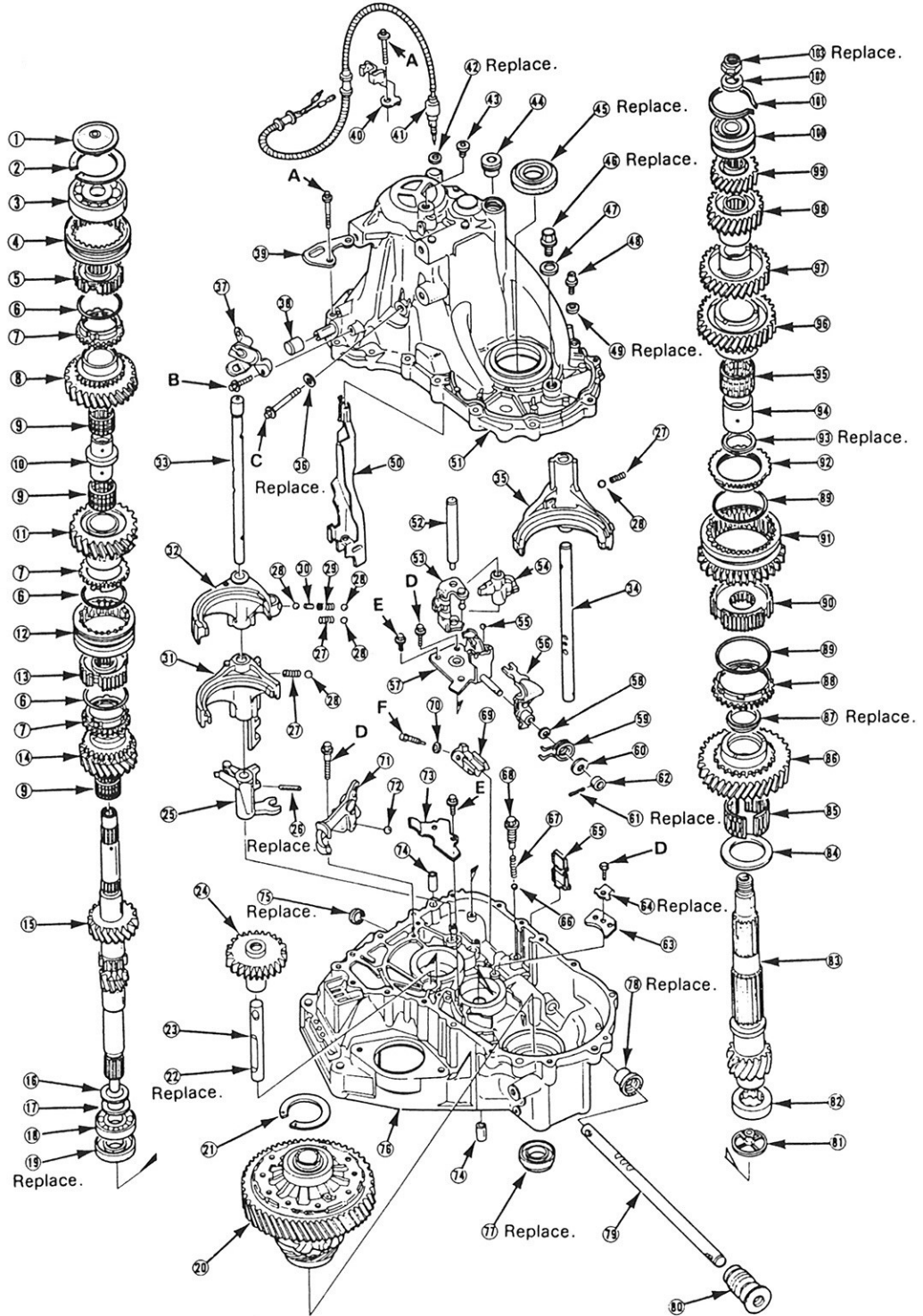

## Torque Value

A	—28 N·m (2.8 kg-m, 20 lb-ft)
B	—24 N·m (2.4 kg-m, 17 lb-ft)
C	—55 N·m (5.5 kg-m, 40 lb-ft)
D	—15 N·m (1.5 kg-m, 11 lb-ft)
E	—12 N·m (1.2 kg-m, 9 lb-ft)
F	—30 N·m (3.0 kg-m, 22 lb-ft)

NOTE: Always clean the magnet (65) whenever the transmission housing is disassembled.

- |   |   |  |
|---|---|--|
| <p>① OIL GUIDE PLATE</p> <p>② THRUST SHIM 70 mm<br/>Selection, page 2-24</p> <p>③ BALL BEARING<br/>Removal, page 2-21<br/>Installation, page 2-23</p> <p>④ 5th SYNCHRO SLEEVE</p> <p>⑤ 5th SYNCHRO HUB<br/>Removal, page 2-21<br/>Installation, page 2-23</p> <p>⑥ SYNCHRO SPRING</p> <p>⑦ SYNCHRO RING</p> <p>⑧ 5th GEAR</p> <p>⑨ NEEDLE BEARING 32 x 37 x 27 mm</p> <p>⑩ SPACER COLLAR</p> <p>⑪ 4th GEAR</p> <p>⑫ 3rd/4th SYNCHRO SLEEVE</p> <p>⑬ 3rd/4th SYNCHRO HUB<br/>Removal, page 2-21<br/>Installation, page 2-23</p> <p>⑭ 3rd GEAR</p> <p>⑮ MAINSHAFT<br/>Measurement, page 2-22</p> <p>⑯ THRUST WASHER 28 mm</p> <p>⑰ SPRING WASHER 28 mm</p> <p>⑱ BALL BEARING<br/>Removal, page 2-17<br/>Installation, page 2-17</p> <p>⑲ OIL SEAL<br/>Installation, page 2-17</p> <p>⑳ DIFFERENTIAL ASSEMBLY<br/>See Section 15</p> <p>㉑ THRUST SHIM 80 mm<br/>Selection, See Section 3</p> <p>㉒ SPRING PIN 4 x 8 mm</p> <p>㉓ REVERSE IDLER GEAR SHAFT</p> <p>㉔ REVERSE IDLER GEAR</p> <p>㉕ 5th/REVERSE SHIFT PIECE</p> <p>㉖ SPRING PIN 5 x 22 mm</p> <p>㉗ SHIFT FORK SPRING</p> <p>㉘ STEEL BALL</p> <p>㉙ SHIFT FORK SPRING</p> <p>㉚ ROLLER</p> <p>㉛ 3rd/4th SHIFT FORK</p> <p>㉜ 5th SHIFT FORK</p> <p>㉝ 5th/REVERSE SHIFT FORK SHAFT</p> <p>㉞ 1st/2nd SHIFT FORK SHAFT</p> <p>㉟ 1st/2nd SHIFT FORK</p> | <p>㊱ WASHER 10 mm</p> <p>㊲ CLUTCH CABLE BRACKET</p> <p>㊳ BREATHER CAP</p> <p>㊴ TRANSMISSION HANGER</p> <p>㊵ HARNESS CLAMP</p> <p>㊶ BACK-UP LIGHT SWITCH<br/>25 N·m (2.5 kg-m, 18 lb-ft)</p> <p>㊷ WASHER 14 mm</p> <p>㊸ SEALING BOLT 16 mm</p> <p>㊹ SEALING BOLT 32 mm<br/>25 N·m (2.5 kg-m, 18 lb-ft)</p> <p>㊺ OIL SEAL<br/>Installation, See Section 3</p> <p>㊻ OIL FILLER PLUG<br/>45 N·m (4.5 kg-m, 33 lb-ft)</p> <p>㊼ WASHER 20 mm</p> <p>㊽ OIL DRAIN PLUG<br/>40 N·m (4.0 kg-m, 29 lb-ft)</p> <p>㊾ WASHER 14 mm</p> <p>㊿ OIL GUTTER PLATE</p> <p>① TRANSMISSION HOUSING</p> <p>② SHIFT GUIDE SHAFT</p> <p>③ INTERLOCK PLATE</p> <p>④ SHIFT GUIDE</p> <p>⑤ STEEL BALL</p> <p>⑥ SELECT ARM</p> <p>⑦ SHIFT ARM HOLDER</p> <p>⑧ THRUST SHIM 10 mm<br/>Selection, page 2-10</p> <p>⑨ RETURN SPRING</p> <p>⑩ WASHER 10 mm</p> <p>⑪ SPRING PIN 3 x 16 mm</p> <p>⑫ COLLAR</p> <p>⑬ BEARING RETAINER PLATE</p> <p>⑭ LOCK WASHER</p> <p>⑮ MAGNET</p> <p>⑯ STEEL BALL</p> <p>⑰ SPRING</p> <p>⑱ SPRING BOLT<br/>22 N·m (2.2 kg-m, 16 lb-ft)</p> <p>⑲ SHIFT ROD GUIDE</p> <p>㉑ SPRING WASHER 8 mm</p> <p>㉒ REVERSE SHIFT FORK</p> <p>㉓ STEEL BALL</p> <p>㉔ BREATHER CHAMBER PLATE</p> <p>㉕ DOWEL PIN</p> <p>㉖ DUST SEAL</p> <p>㉗ CLUTCH HOUSING</p> | <p>㉘ OIL SEAL<br/>Installation, See Section 3</p> <p>㉙ OIL SEAL</p> <p>㉚ SHIFT ROD</p> <p>㉛ BOOT</p> <p>㉜ OIL GUIDE PLATE</p> <p>㉝ ROLLER BEARING<br/>Removal, page 2-16<br/>Installation, page 2-16</p> <p>㉞ COUNTERSHAFT<br/>Measurement, page 2-29</p> <p>㉟ WASHER 40 x 54 mm<br/>Selection, page 2-27</p> <p>① NEEDLE BEARING 37 x 42 x 27.5 mm</p> <p>② 1st GEAR</p> <p>③ FRICTION DAMPER<br/>Removal, page 2-26</p> <p>④ SYNCHRO RING</p> <p>⑤ SYNCHRO SPRING</p> <p>⑥ 1st/2nd SYNCHRO HUB</p> <p>⑦ REVERSE GEAR 1st/2nd SYNCHRO SLEEVE</p> <p>⑧ SYNCHRO RING</p> <p>⑨ FRICTION DAMPER<br/>Removal, page 2-26</p> <p>⑩ SPACER COLLAR<br/>Selection, page 2-27</p> <p>⑪ NEEDLE BEARING 42 x 47 x 27.5 mm</p> <p>⑫ 2nd GEAR</p> <p>⑬ 3rd GEAR<br/>Removal, page 2-28<br/>Installation, page 2-30</p> <p>⑭ 4th GEAR<br/>Removal, page 2-28<br/>Installation, page 2-30</p> <p>⑮ 5th GEAR<br/>Removal, page 2-28<br/>Installation, page 2-30</p> <p>⑯ BALL BEARING<br/>Removal, page 2-28<br/>Installation, page 2-30</p> <p>⑰ SNAP RING</p> <p>⑱ SPRING WASHER 23 mm</p> <p>⑲ LOCKNUT<br/>110→0→110 N·m (11.0→0→11.0 kg-m,<br/>80→0→80 lb-ft)</p> |
|---|---|--|

# Transmission Housing

## Removal

NOTE: Place the clutch housing on two pieces of lumber thick enough to keep the mainshaft from hitting the workbench.

1. Remove the back-up light switch.
  2. Remove the clutch cable bracket.
  3. Remove the reverse idle gear shaft bolt.
  4. Remove the 32 mm sealing bolt.
  5. Remove the transmission housing attaching bolts.
- NOTE: It is not necessary to remove the 16 mm sealing bolt on disassembly.

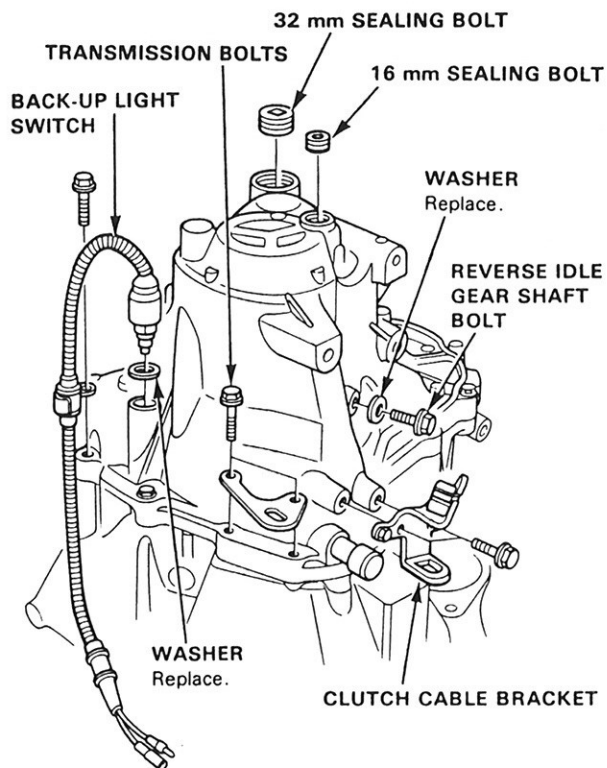

6. Expand the snap ring on the countershaft ball bearing and remove it from the groove using a pair of snap ring pliers.

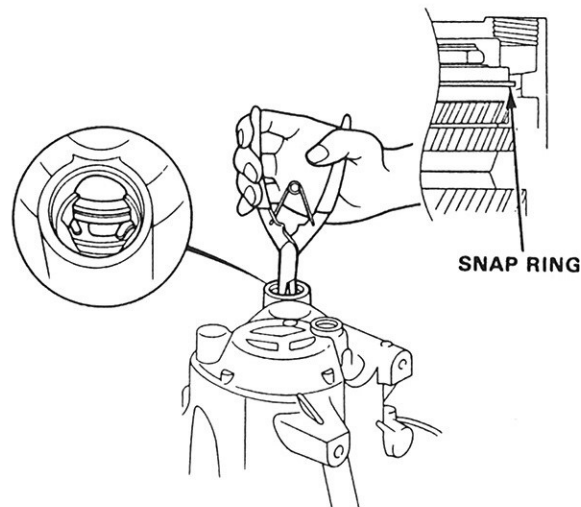

7. Separate the clutch housing from the transmission housing. Clean the mating surfaces thoroughly.
8. Remove the thrust shim and oil guide plate from the transmission housing.

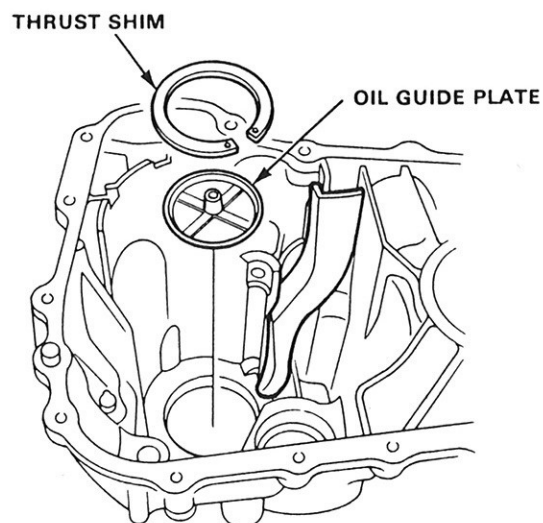

# Reverse Shift Fork, 5th/Reverse Shift Piece

## Clearance Inspection

1. Measure the bottom clearance between the reverse shift fork and 5th/reverse shift piece pin.

Standard: 0.05–0.35 mm (0.002–0.014 in.)  
 Service Limit: 0.5 mm (0.020 in.)

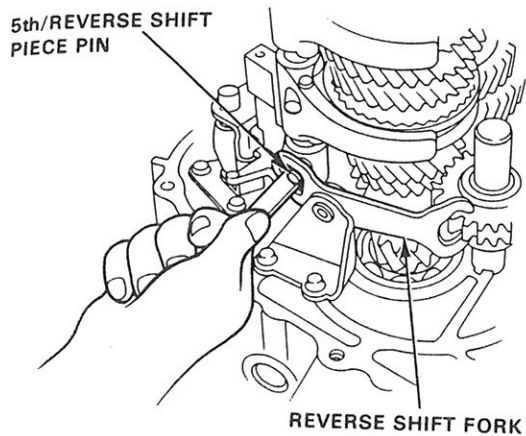

2. Measure the side clearance between the reverse shift fork and 5th/reverse shift piece pin.

Standard: 0.4–0.8 mm (0.016–0.031 in.)  
 Service Limit: 1.0 mm (0.039 in.)

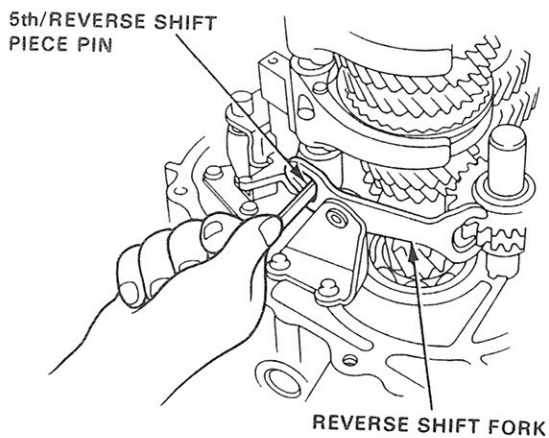

3. If the clearance exceeds the service limit, measure the width of the L-groove in the reverse shift fork.

Standard: 7.05–7.25 mm (0.278–0.285 in.)

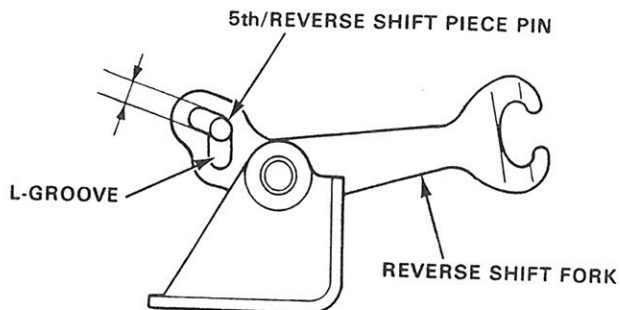

Replace the reverse shift fork with a new one if the width exceeds 7.25 mm (0.285 in.)

Standard: 7.4–7.7 mm (0.291–0.303 in.)

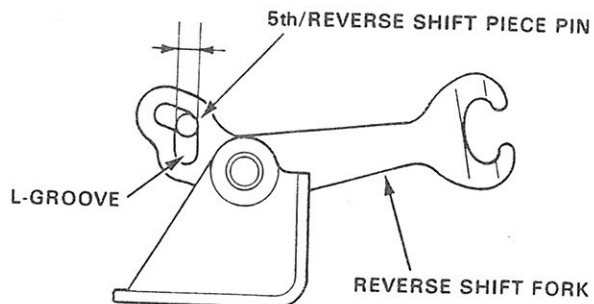

Replace the reverse shift fork with a new one if the width exceeds 7.7 mm (0.303 in.)

# Reverse Shift Fork, Reverse Idle Gear

## Clearance Inspection

1. Measure the clearance between the reverse idle gear and reverse shift fork.

**Standard:** 0.5–1.1 mm (0.020–0.043 in.)  
**Service Limit:** 1.8 mm (0.071 in.)

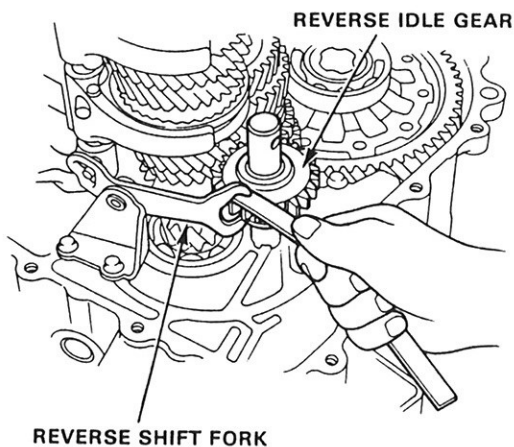

2. If the clearance exceeds the service limit, measure the width of the reverse shift fork pawl groove.

**Standard:** 13.0–13.3 mm (0.512–0.524 in.)

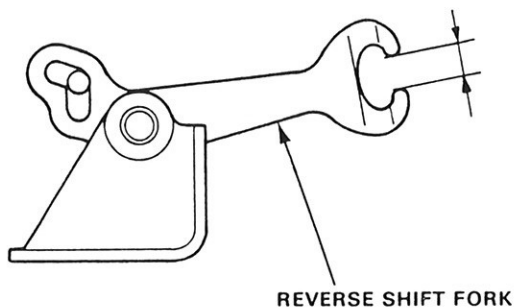

Replace the reverse shift fork with a new one if the width exceeds 13.3 mm (0.524 in.).

## Removal

1. Remove the reverse shift fork from the clutch housing.

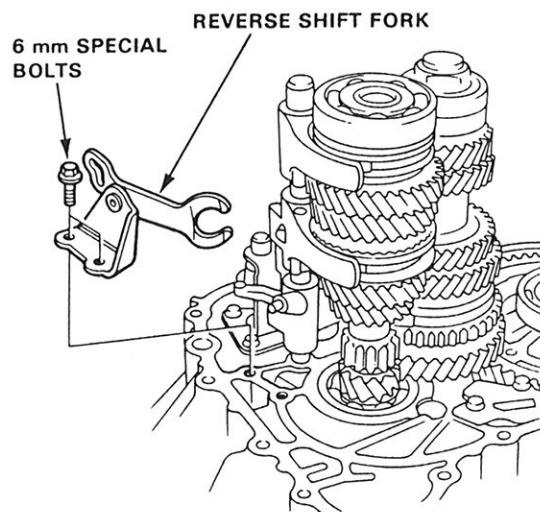

2. Remove the reverse idle gear shaft and reverse idle gear from the clutch housing together.

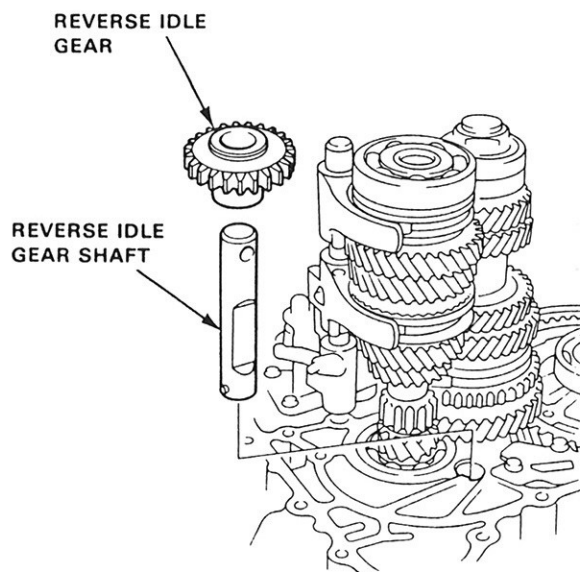



## Shift Arm, Shift Guide

### Clearance Inspection

1. Measure the clearance between the shift arm and shift guide.

**Standard:** 0.1–0.3 mm (0.004–0.012 in.)  
**Service Limit:** 0.6 mm (0.024 in.)

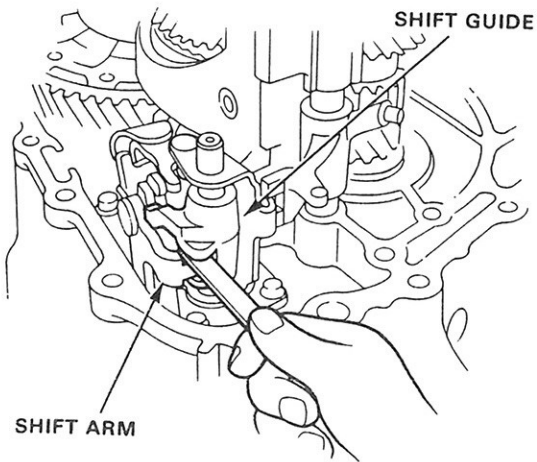

2. If the clearance exceeds the service limit, measure the width of the groove in the shift guide.

**Standard:** 8.1–8.2 mm (0.319–0.323 in.)

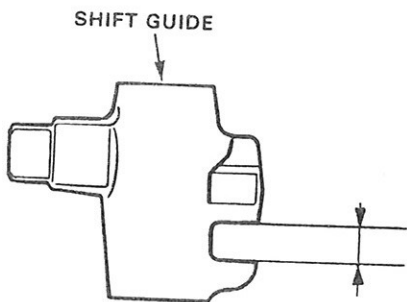

Replace the shift guide with a new one if the width exceeds 8.2 mm (0.323 in.)

## Selector Arm, Interlock

### Clearance Inspection

1. Measure the clearance between the selector arm and interlock.

**Standard:** 0.05–0.25 mm (0.002–0.01 in.)  
**Service Limit:** 0.5 mm (0.02 in.)

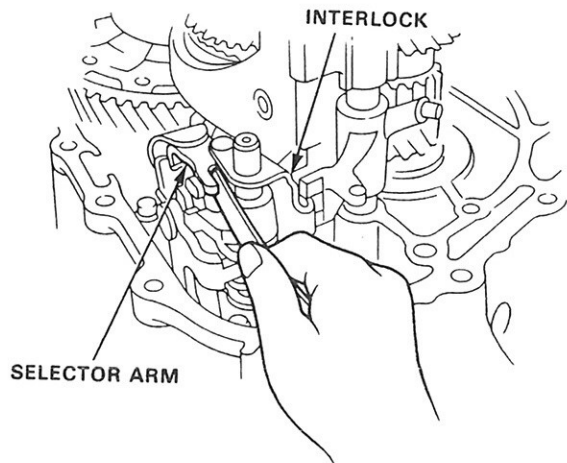

2. If the clearance exceeds the service limit, measure the width of the groove in the selector arm.

**Standard:** 10.05–10.15 mm (0.396–0.4 in.)

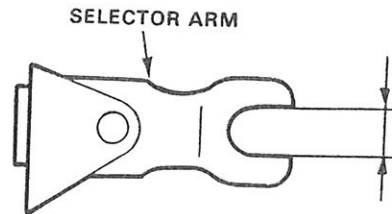

Replace the selector arm with a new one if the width exceeds 10.15 mm (0.4 in.)

# Shift Arm Holder Assembly

## Clearance Inspection

1. Measure the clearance between the 10 mm washer and the 10 mm thrust shim.

Standard: 0.01–0.2 mm (0.0003–0.008 in.)

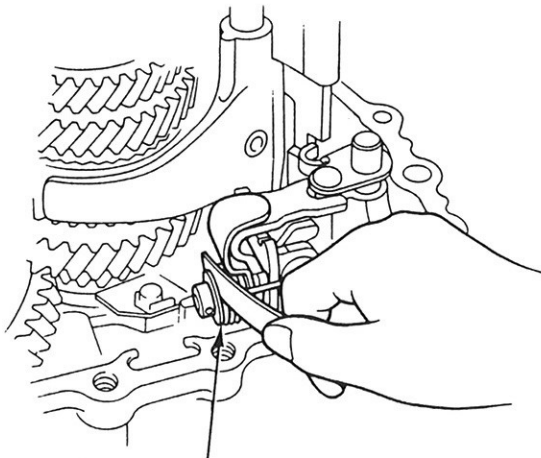

10 mm WASHER

2. If the clearance exceeds the standard, select the appropriate 10 mm thrust shim for the correct clearance from the chart below.

	PART NUMBER	THICKNESS
A	24435-689-000	0.8 mm (0.032 in.)
B	24436-689-000	1.0 mm (0.039 in.)
C	24437-689-000	1.2 mm (0.047 in.)
D	24438-689-000	1.4 mm (0.055 in.)
E	24439-689-000	1.6 mm (0.063 in.)

## Removal

1. Remove the shift guide shaft, then remove the shift guide and interlock from the clutch housing.

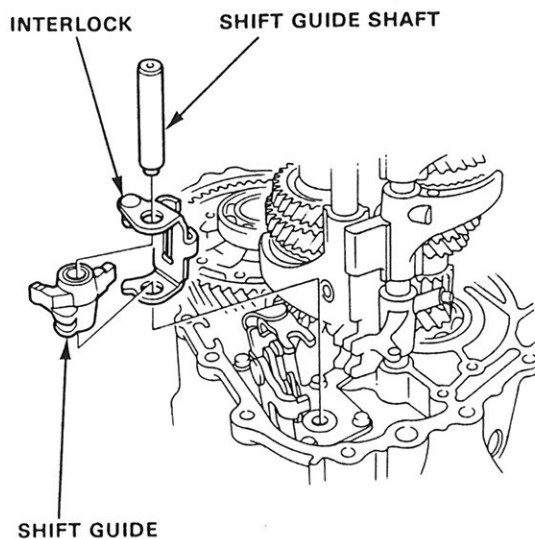

SHIFT GUIDE

2. Remove the shift arm holder assembly from the clutch housing.

6 mm SPECIAL BOLTS

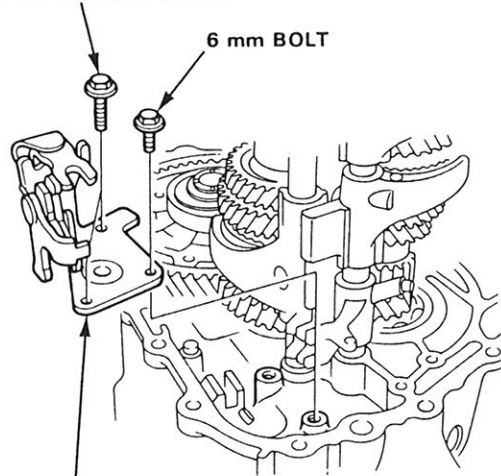

SHIFT ARM HOLDER

# Transmission

## Disassembly

1. Remove the mainshaft assembly and countershaft assembly with the shift fork from the clutch housing.  
NOTE: Tape the mainshaft spline to protect it before removing the mainshaft and countershaft assemblies.

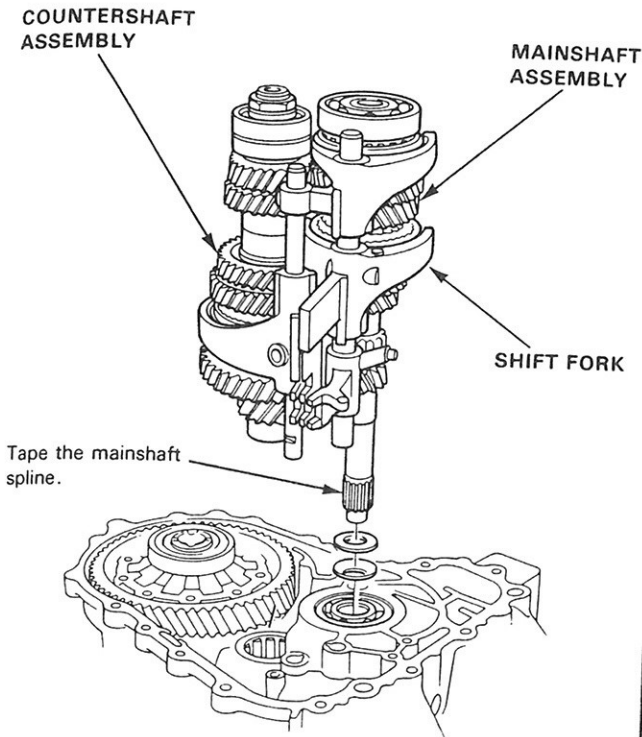

2. Remove the differential assembly from the clutch housing.

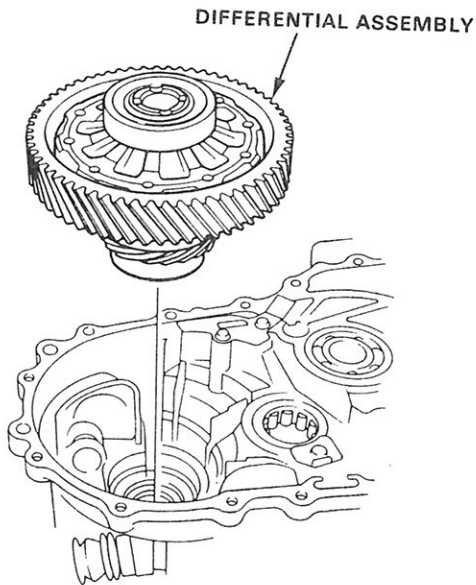

3. Remove the bolt and washer which hold the shift rod guide.
4. Remove the bolt, steel ball and spring from the clutch housing.

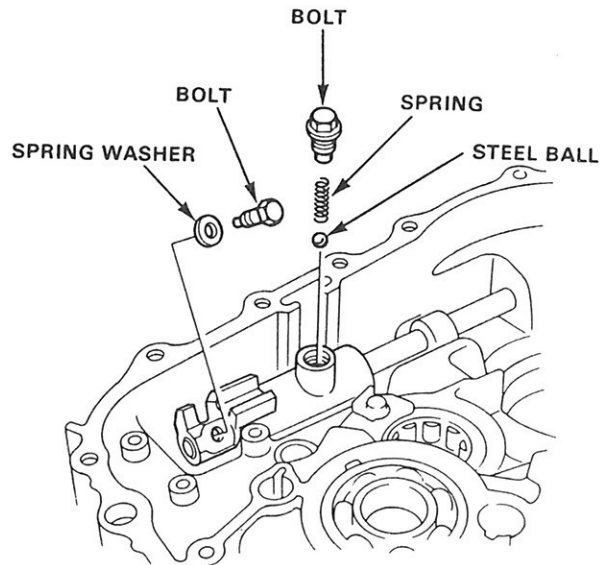

5. Remove the boot and shift rod, then remove the shift rod guide and oil seal from the clutch housing.

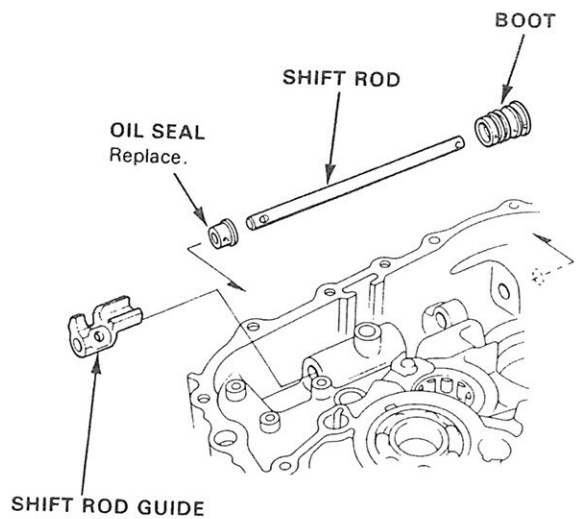

## Shift Arm, Shift Rod Guide

### Clearance Inspection

1. Measure the clearance between the shift arm and shift rod guide.

**Standard:** 0.05–0.35 mm (0.002–0.014 in.)  
**Service Limit:** 0.8 mm (0.032 in.)

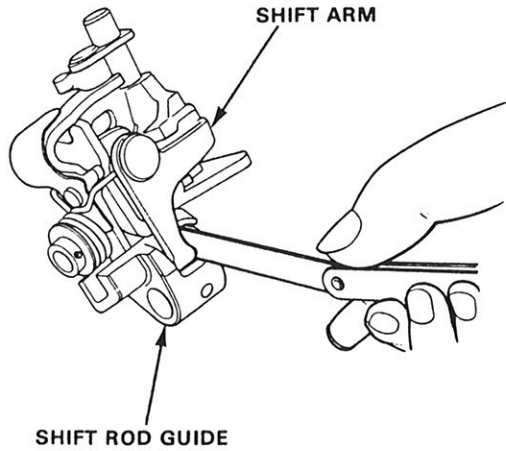

2. If the clearance exceeds the service limit, measure the width of the groove in the shift rod guide.

**Standard:** 12.05–12.15 mm (0.474–0.478 in.)

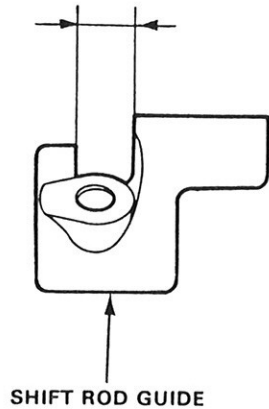

If the width of the groove exceeds the standard, replace the shift rod guide with a new one.

## Select Arm, Shift Rod Guide

### Clearance Inspection

1. Measure the clearance between the select arm and shift rod guide.

**Standard:** 0.05–0.25 mm (0.002–0.010 in.)  
**Service Limit:** 0.5 mm (0.020 in.)

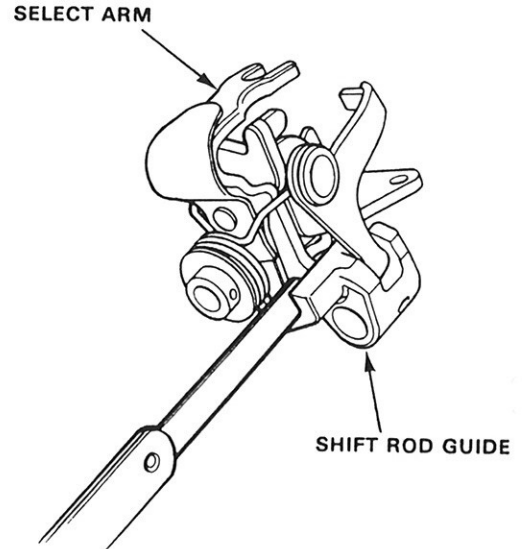

2. If the clearance exceeds the service limit, measure the width of the select arm.

**Standard:** 11.90–12.00 mm (0.469–0.472 in.)

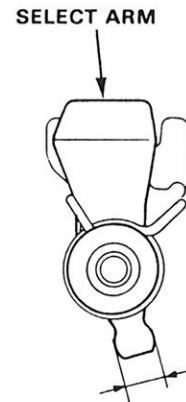

If the width exceeds the standard, replace the select arm with a new one.

# Shift Arm Holder Assembly

## Disassembly/Reassembly

To remove the selector arm from the shift arm holder for shimming or replacement, drive out the spring pin with the pin driver.

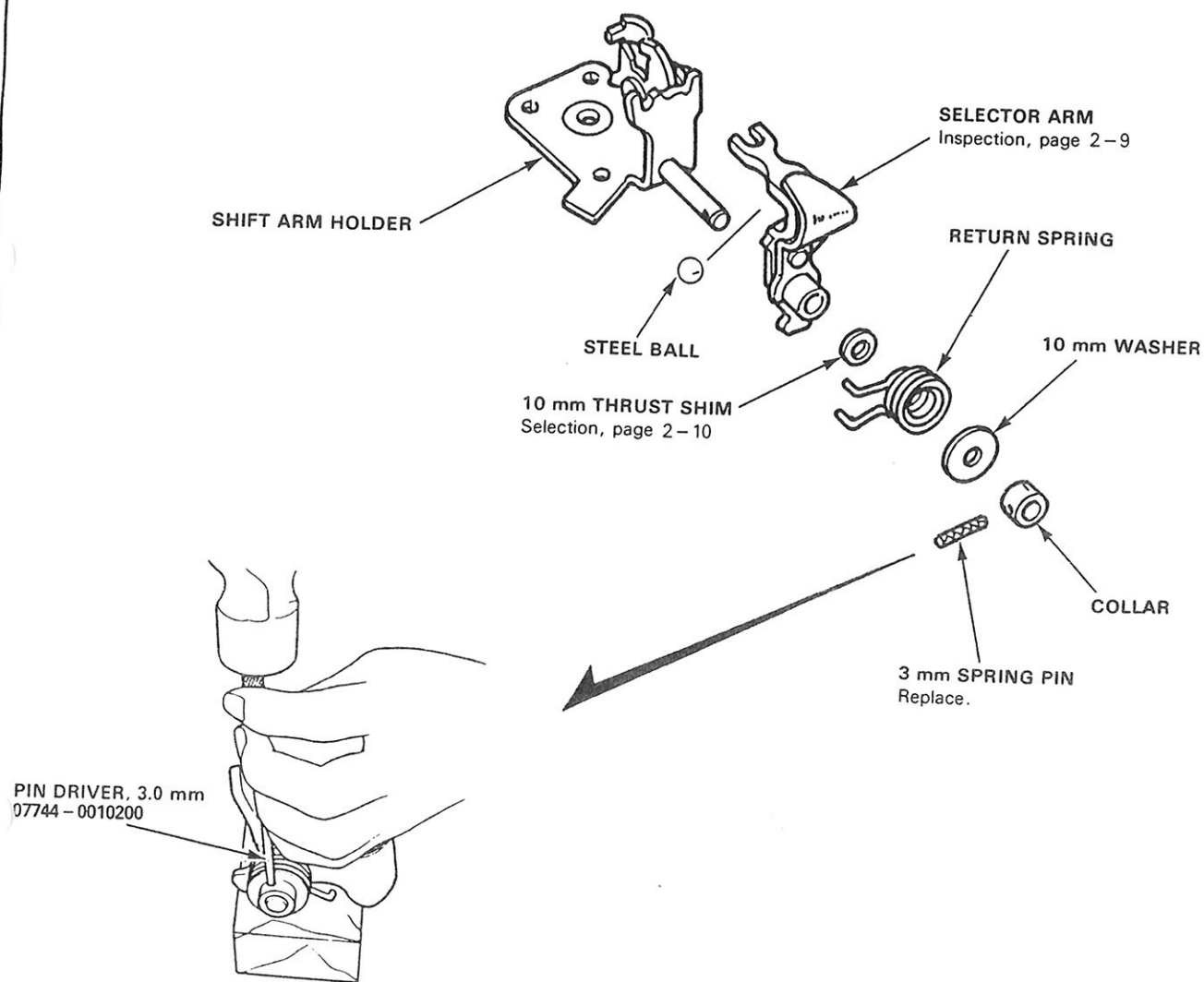

## Shift Fork, 5th Reverse Shift Piece and Shift Guide

### Clearance Inspection

1. Measure the clearance between the shift fork, the 5th/Reverse shift piece and shift guide.

**Standard:** 0.2–0.5 mm (0.008–0.020 in.)  
**Service Limit:** 0.8 mm (0.032 in.)

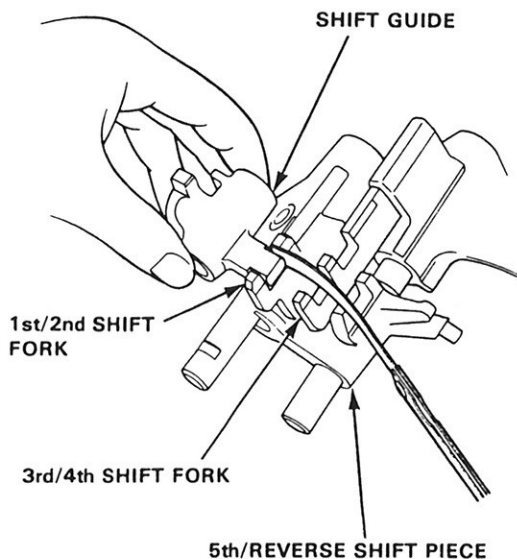

2. If the clearance exceeds the service limit, measure the width of the shift guide.

**Standard:** 11.9–12.0 mm (0.469–0.472 in.)

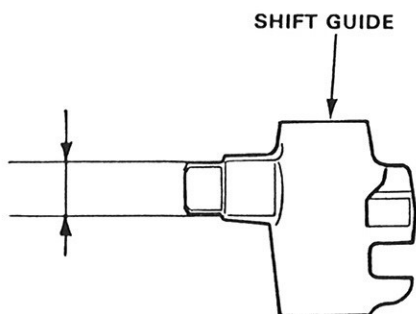

Replace the shift guide with a new one if the width exceeds the standard.

## Shift Fork, Synchro Sleeve

### Clearance Inspection

1. Check the clearance between each shift fork and its matching synchro sleeve.

**Standard:** 0.45–0.65 mm (0.018–0.026 in.)  
**Service Limit:** 1.00 mm (0.039 in.)

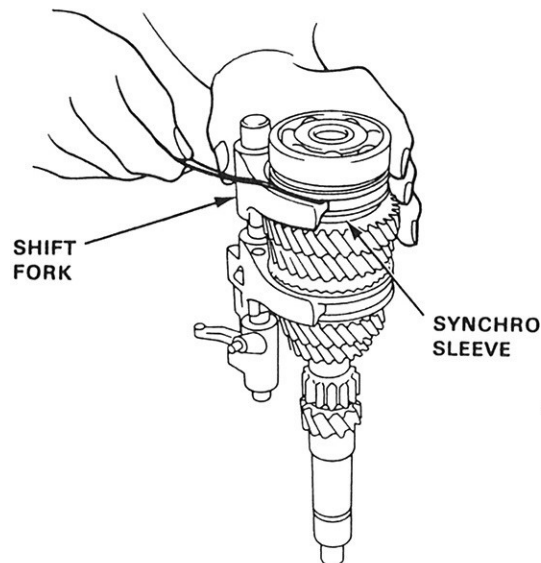

2. If the clearance exceeds the service limit, measure the width of the shift fork fingers.

**Standard:** 7.4–7.5 mm (0.291–0.295 in.)

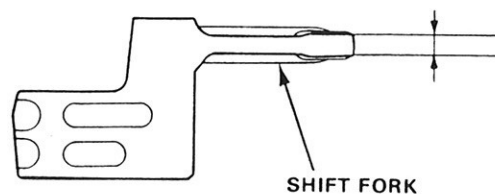

Replace the shift fork with a new one if the width exceeds the standard.



# Shift Fork Shaft Assembly

## Disassembly/Reassembly

**NOTE:**

- When disassembling, pay attention to the steel balls as the springs may force them out.
- When assembling, install the shift fork shaft with its detents facing the hole where the balls are inserted.



Prior to reassembling, clean all the parts in solvent, dry them and apply lubricant to any contact parts.

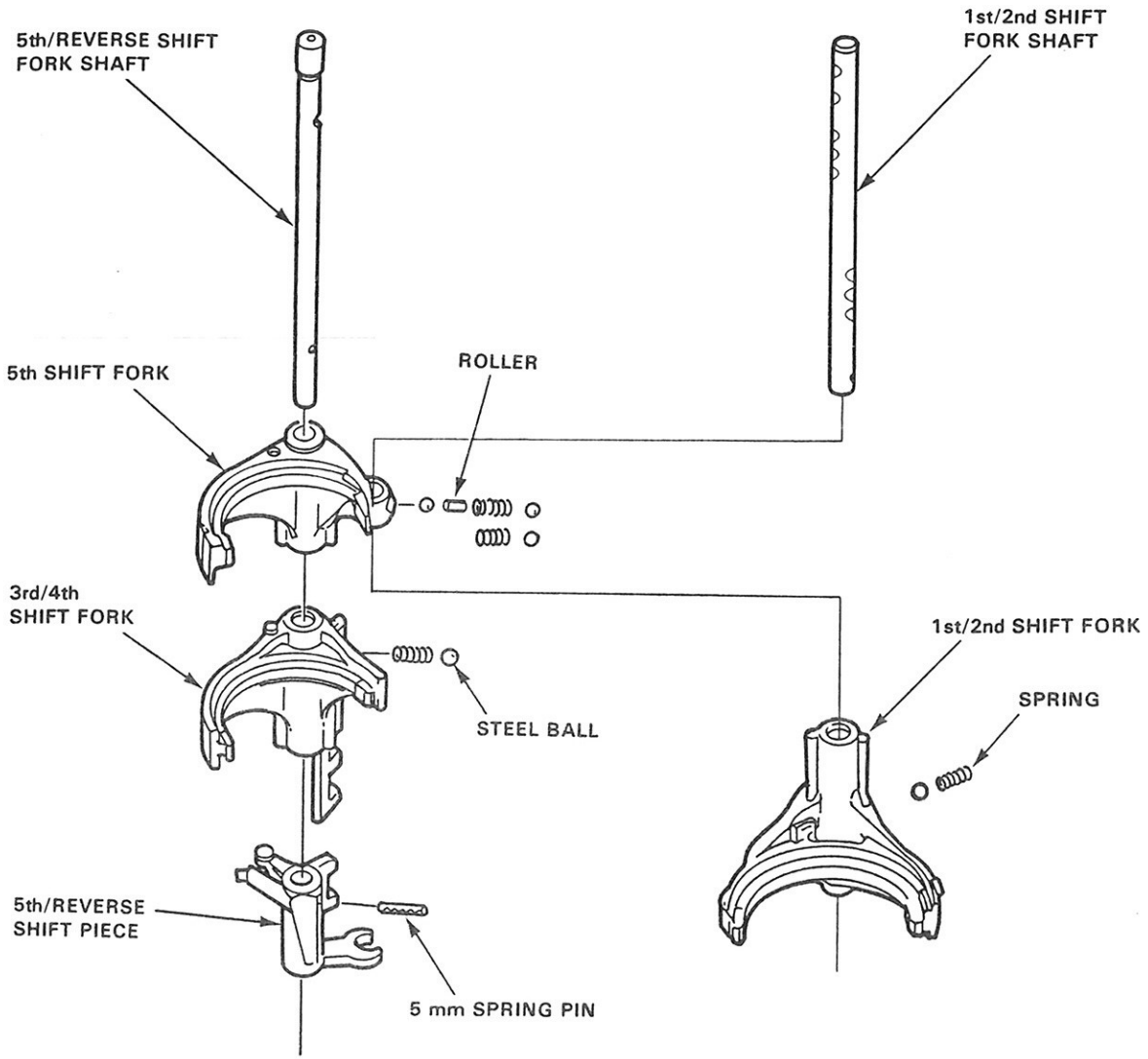

PIN DRIVER, 5.0 mm  
07744 - 0010400

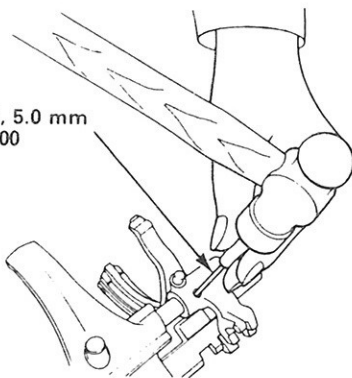

# Countershaft Bearing (Clutch Housing)

## Replacement

1. Bend the tab on the lock washer down, then remove the bolt and bearing retainer plate.

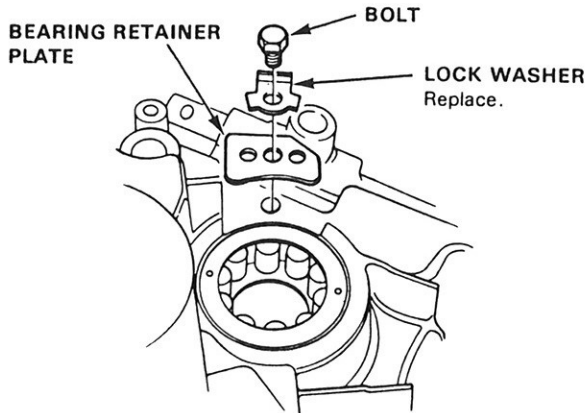

2. Remove the roller bearing with the special tool, then remove the oil guide plate.

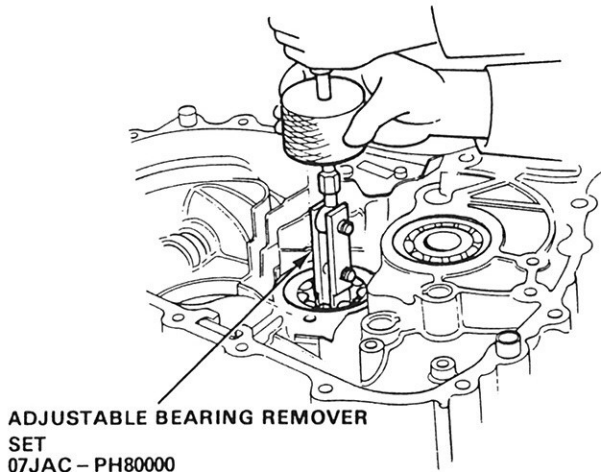

3. Position the oil guide plate and new roller bearing in the bore of the clutch housing.

NOTE: Position the roller bearing with the oil hole facing up.

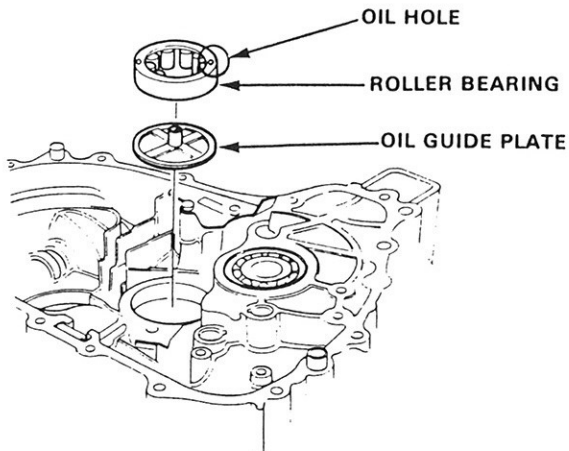

4. Drive the roller bearing in using the special tools.

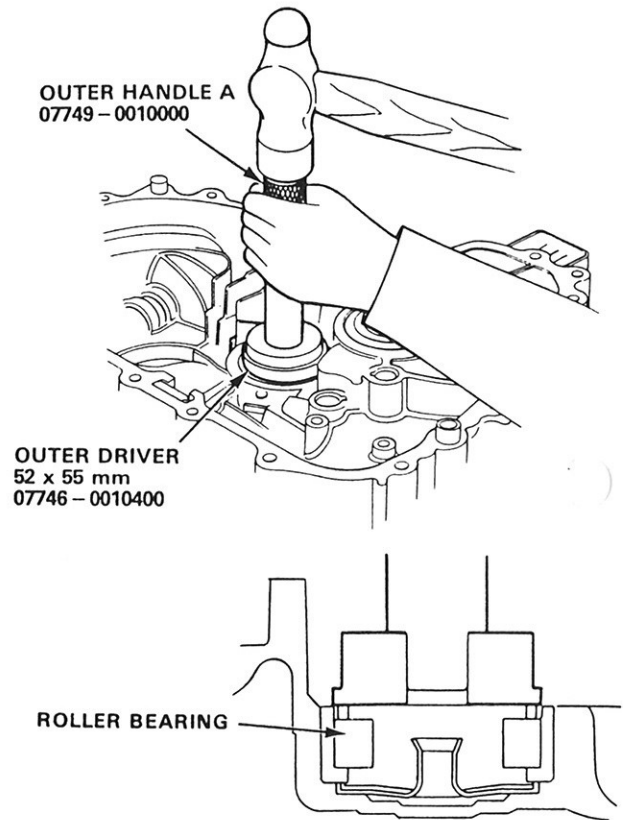

5. Install the bearing retainer plate and new lock washer, then bend the tab against the bolt head.

15 N·m (1.5 kg-m, 11 lb-ft)

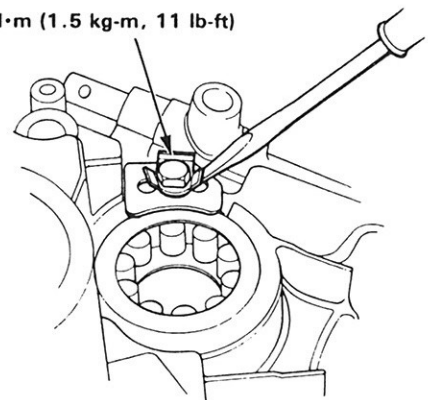

# Mainshaft Bearing, Oil Seal (Clutch Housing)

## Replacement

1. Remove the ball bearing with the special tool.

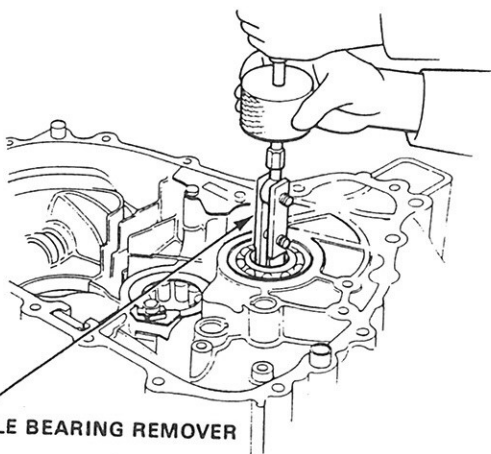

ADJUSTABLE BEARING REMOVER  
SET  
07JAC - PH80000

2. Remove the oil seal from the clutch side.

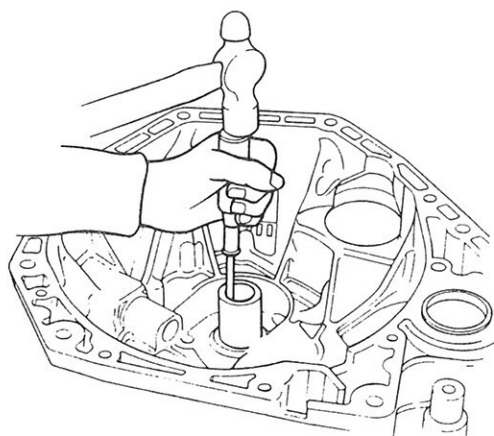

3. Drive in a new oil seal from the transmission side using the special tools.

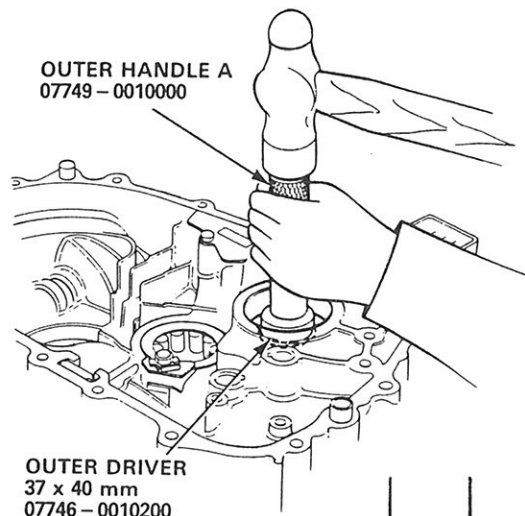

OUTER HANDLE A  
07749 - 0010000

OUTER DRIVER  
37 x 40 mm  
07746 - 0010200

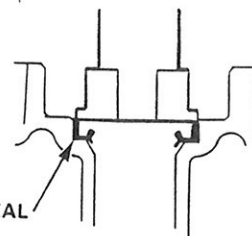

OIL SEAL

4. Drive in a new ball bearing using the special tools.

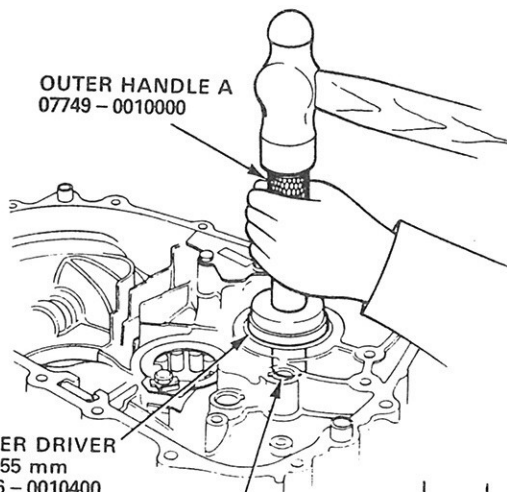

OUTER HANDLE A  
07749 - 0010000

OUTER DRIVER  
52 x 55 mm  
07746 - 0010400

PILOT DRIVER,  
28 x 12 mm  
07746 - 0041100

BALL BEARING

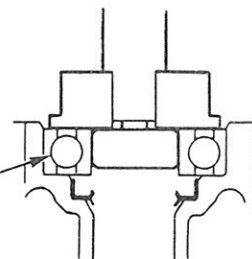

# Mainshaft Assembly

## Index

**NOTE:**

- The needle bearings are the same size.
- The synchro rings are the same size.
- The synchro springs are the same size.
- The 3rd/4th and 5th synchro hubs are installed with a press.

 Prior to reassembling, clean all the parts in solvent, dry them and apply lubricant to any contact parts. The 3rd/4th and 5th synchro hubs, however, should be installed with a press before lubricating them.

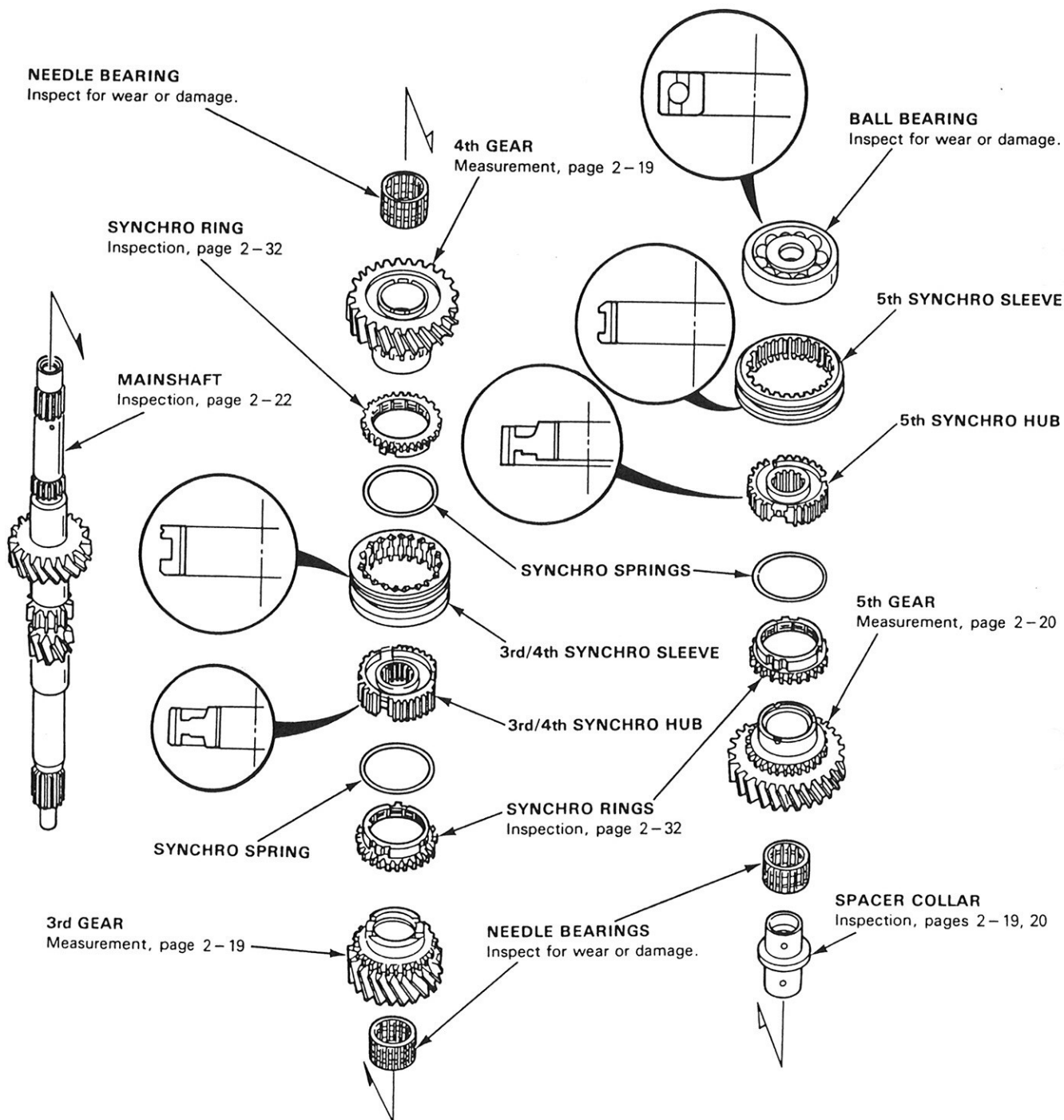

## Clearance Inspection

1. Measure the clearance between 2nd and 3rd gears.  
**3rd Gear Clearance:**  
**Standard:** 0.06–0.21 mm (0.002–0.008 in.)  
**Service Limit:** 0.3 mm (0.012 in.)

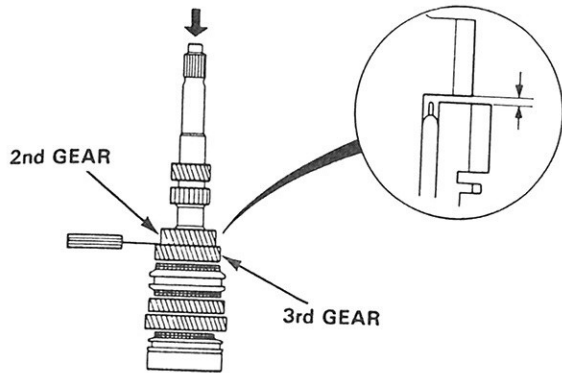

2. If the clearance exceeds the service limit, measure the thickness of 3rd gear.  
**3rd Gear Thickness:**  
**Standard:** 31.92–31.97 mm (1.257–1.259 in.)  
**Service Limit:** 31.85 mm (1.254 in.)

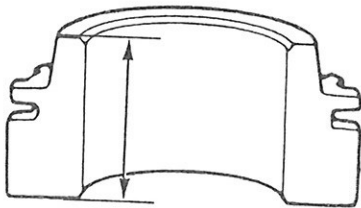

If the thickness of 3rd gear is less than the service limit, replace 3rd gear.  
 If 3rd gear is within the service limit, replace the 3rd/4th synchro hub.

3. Measure the clearance between 4th gear and the spacer collar.  
**Standard:** 0.06–0.21 mm (0.002–0.008 in.)  
**Service Limit:** 0.3 mm (0.012 in.)

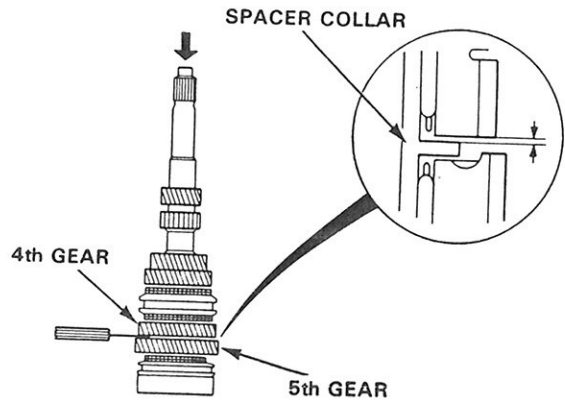

4. If the clearance exceeds the service limit, measure distance (A) on the spacer collar.  
**Standard:** 27.03–27.08 mm (1.064–1.066 in.)  
**Service Limit:** 27.01 mm (1.063 in.)

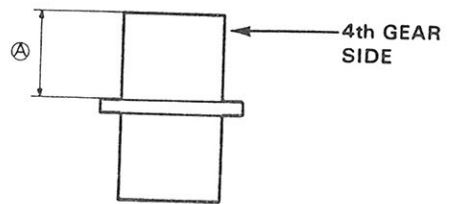

5. If distance (A) is less than the service limit, measure the thickness of 4th gear.  
**4th Gear Thickness:**  
**Standard:** 31.42–31.47 mm (1.237–1.239 in.)  
**Service Limit:** 31.35 mm (1.234 in.)

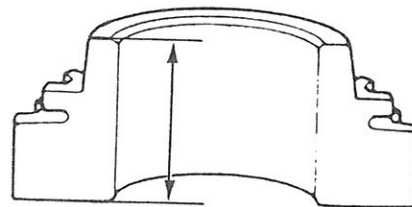

Replace 4th gear if its thickness is less than the service limit.  
 If 4th gear is within the service limit, replace the 3rd/4th synchro hub.

(cont'd)

# Mainshaft Assembly

## Clearance Inspection (cont'd)

6. Measure the clearance between 5th gear and the spacer collar.

**Standard:** 0.06–0.21 mm (0.002–0.008 in.)  
**Service Limit:** 0.33 mm (0.013 in.)

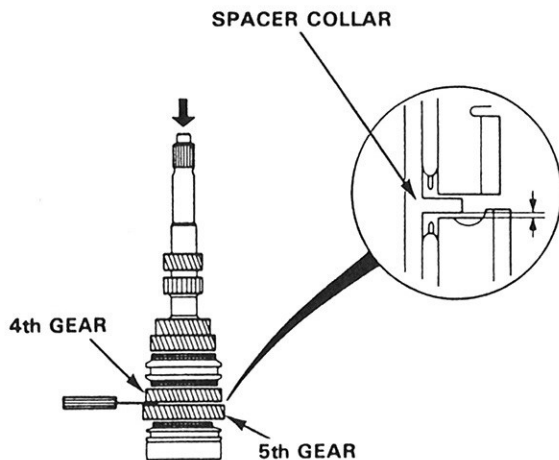

7. If the clearance exceeds the service limit, measure distance ⑧ on the spacer collar.

**Standard:** 27.03–27.08 mm (1.064–1.066 in.)  
**Service Limit:** 27.01 mm (1.063 in.)

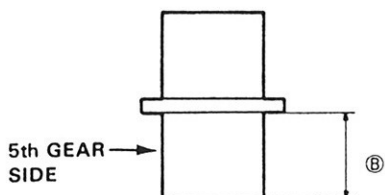

8. If distance ⑧ is less than the service limit, measure the thickness of 5th gear.

**5th Gear Thickness:**  
**Standard:** 29.42–29.47 mm (1.158–1.160 in.)  
**Service Limit:** 29.35 mm (1.156 in.)

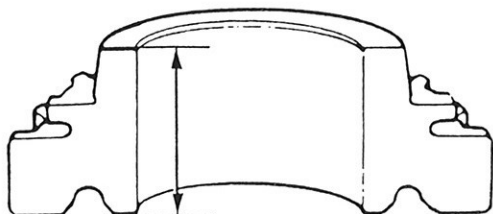

Replace 5th gear if its thickness is less than the service limit.

If the thickness of 5th gear is within the service limit, replace the 5th synchro hub.



## Disassembly

1. Remove the ball bearing using a bearing puller as shown.

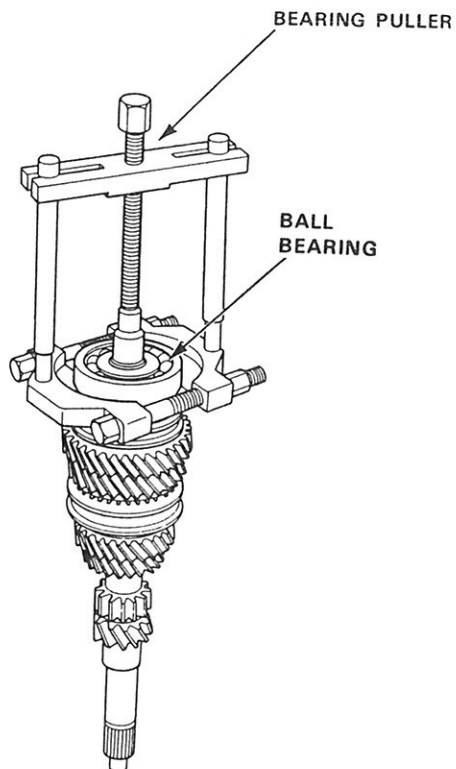

**CAUTION:** Remove the synchro hubs using a press and steel blocks as shown. Use of a jaw-type puller can cause damage to the gear teeth.

2. Support 4th gear on steel blocks as shown and press the shaft out of the 5th synchro hub.

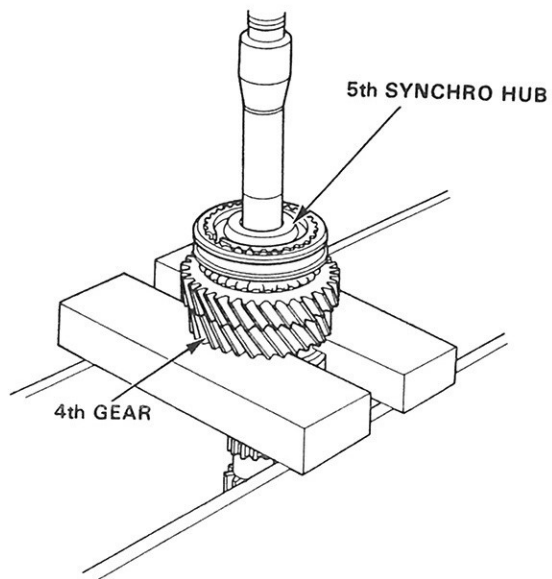

3. In the same manner as above, support the 3rd gear on steel blocks and press the shaft out of the 3rd/4th synchro hub.

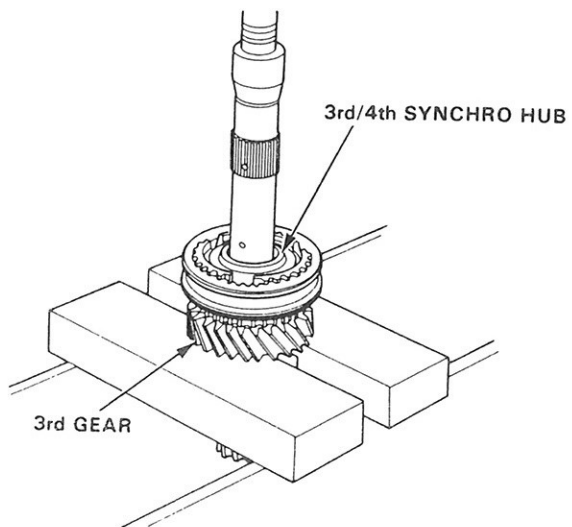

# Mainshaft Assembly

## Inspection

1. Measure the mainshaft at points A, B and C.

<b>Standards:</b>	<b>A: Ball bearing surface</b>
	27.977—28.990 mm (1.101—1.142 in.)
	<b>B: Needle bearing surface</b>
	31.984—32.000 mm (1.259—1.260 in.)
	<b>C: Ball bearing surface</b>
	21.987—22.000 mm (0.866—0.866 in.)
<b>Service Limits:</b>	<b>A: 27.93 mm (1.100 in.)</b>
	<b>B: 31.93 mm (1.257 in.)</b>
	<b>C: 21.94 mm (0.864 in.)</b>

Inspect oil passages for clogging.

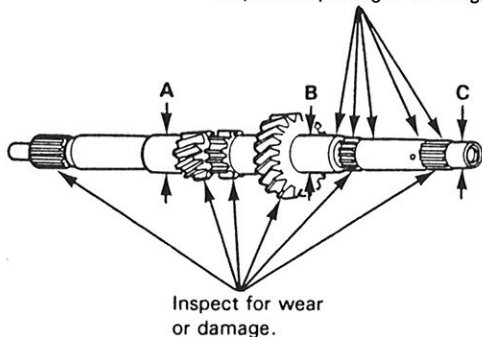

Replace the mainshaft if any part of it is less than the service limit.

2. Inspect for runout.

<b>Standard:</b>	0.02 mm (0.0008 in.)
<b>Service Limit:</b>	0.05 mm (0.0020 in.)

NOTE: Support the mainshaft at the A and B points as shown.

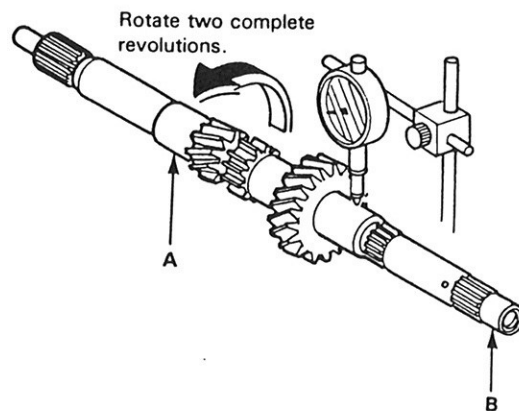

Replace the mainshaft if the runout exceeds the service limit.

## Reassembly

### CAUTION:

- Install the 3rd/4th and 5th synchro hubs using a press before applying any lubricant to them.
  - When installing the 3rd/4th and 5th synchro hubs, support the shaft on the steel blocks and install synchro hubs using a press.
  - Install the 3rd/4th and 5th synchro hubs by the pressure (stable load) of 2,000 kg.
1. Support 2nd gear on steel blocks as shown, then install the 3rd/4th synchro hub using a press.

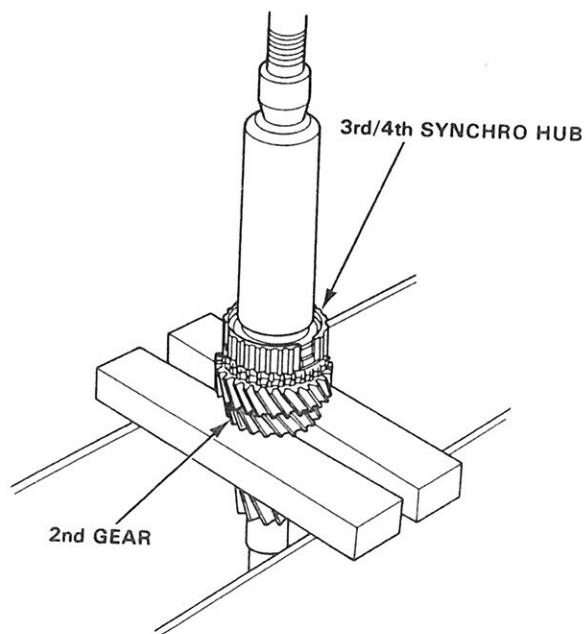

2. Install the 5th synchro hub using a press as shown.

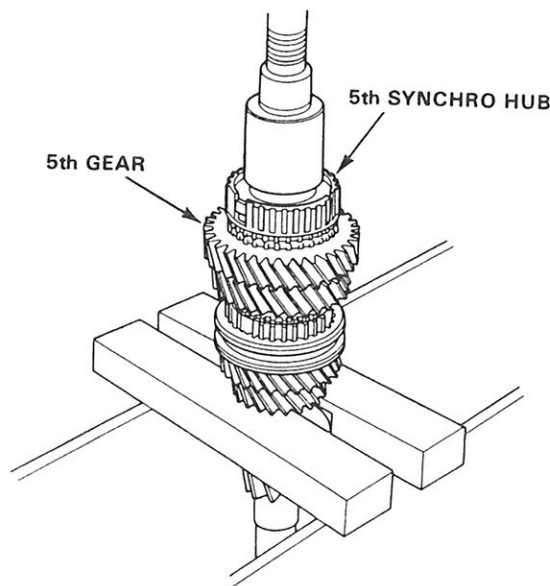

3. Install the ball bearing using a press as shown.

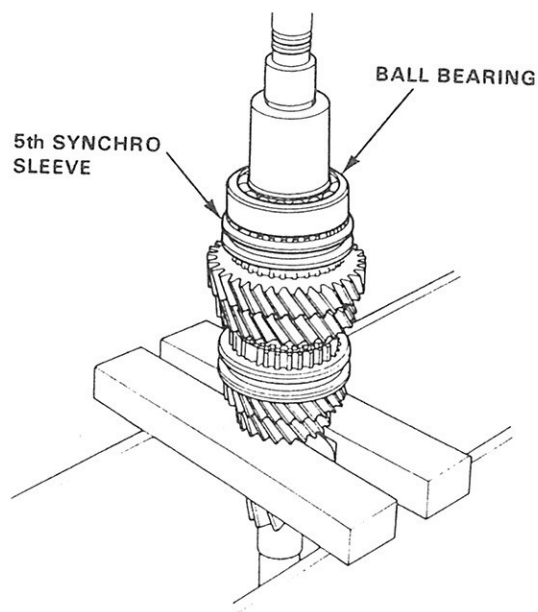

# Mainshaft Thrust Shim

## Adjustment

1. Remove the thrust shim and oil guide plate from the transmission housing (page 2-6).
2. Install the 3rd/4th synchro hub, spacer collar, 5th synchro hub, ball bearing and thrust washer on the mainshaft. Install the assembly in the transmission housing.
3. Measure distance B between the end of the transmission housing and thrust washer.

**NOTE:**

- Use a straight edge and feeler gauge.
- Measure at three locations and average the readings.

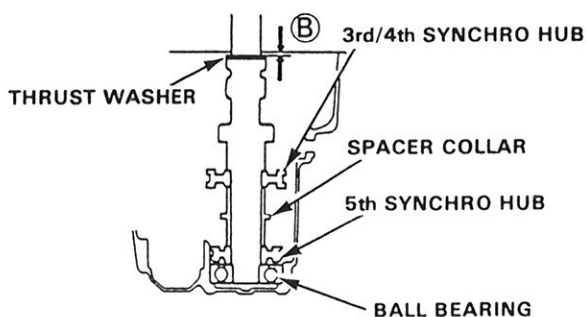

4. Measure distance C between the surfaces of the clutch housing and the bearing inner race.

**NOTE:**

- Use a straight edge and feeler gauge.
- Measure at three locations and average the readings.

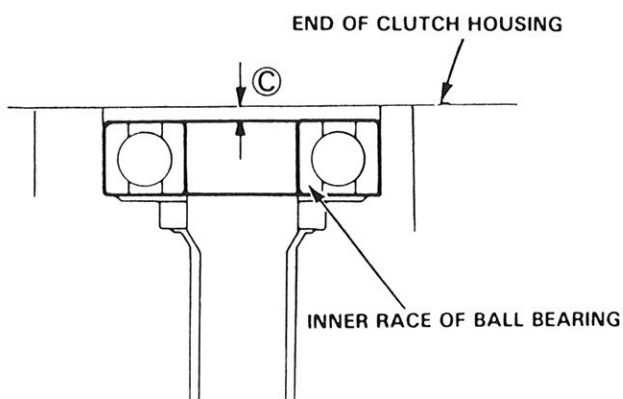

5. Select the proper shim on the basis of the following calculations:

**NOTE:** Do not use more than one shim.

(Basic Formula)

$$(B) + (C) - 1.00 = \text{shim thickness}$$

**Example of calculation:**

Distance B (2.05 mm) + Distance C (0.09 mm) = 2.14 mm  
 subtract the spring washer height (1.00 mm) = the required thrust shim (1.14 mm)

Select the thrust shim from chart below.

	PART NUMBER	THICKNESS
A	23931-PL3-B00	0.60 mm (0.0236 in.)
B	23932-PL3-B00	0.63 mm (0.0284 in.)
C	23933-PL3-B00	0.66 mm (0.0260 in.)
D	23934-PL3-B00	0.69 mm (0.0272 in.)
E	23935-PL3-B00	0.72 mm (0.0283 in.)
F	23936-PL3-B00	0.75 mm (0.0295 in.)
G	23937-PL3-B00	0.78 mm (0.0307 in.)
H	23938-PL3-B00	0.81 mm (0.0319 in.)
I	23939-PL3-B00	0.84 mm (0.0331 in.)
J	23940-PL3-B00	0.87 mm (0.0343 in.)
K	23941-PL3-B00	0.90 mm (0.0354 in.)
L	23942-PL3-B00	0.93 mm (0.0366 in.)
M	23943-PL3-B00	0.96 mm (0.0378 in.)
N	23944-PL3-B00	0.99 mm (0.0390 in.)
O	23945-PL3-B00	1.02 mm (0.0402 in.)
P	23946-PL3-B00	1.05 mm (0.0413 in.)
Q	23947-PL3-B00	1.08 mm (0.0425 in.)
R	23948-PL3-B00	1.11 mm (0.0437 in.)
S	23949-PL3-B00	1.14 mm (0.0449 in.)
T	23950-PL3-B00	1.17 mm (0.0461 in.)
U	23951-PL3-B00	1.20 mm (0.0472 in.)
V	23952-PL3-B00	1.23 mm (0.0484 in.)
W	23953-PL3-B00	1.26 mm (0.0496 in.)
X	23954-PL3-B00	1.29 mm (0.0508 in.)
Y	23955-PL3-B00	1.32 mm (0.0520 in.)
Z	23956-PL3-B00	1.35 mm (0.0531 in.)
AA	23957-PL3-B00	1.38 mm (0.0543 in.)
AB	23958-PL3-B00	1.41 mm (0.0555 in.)
AC	23959-PL3-B00	1.44 mm (0.0567 in.)
AD	23960-PL3-B00	1.47 mm (0.0579 in.)
AE	23961-PL3-B00	1.50 mm (0.0591 in.)
AF	23962-PL3-B00	1.53 mm (0.0602 in.)
AG	23963-PL3-B00	1.56 mm (0.0614 in.)
AH	23964-PL3-B00	1.59 mm (0.0626 in.)
AI	23965-PL3-B00	1.62 mm (0.0638 in.)
AJ	23966-PL3-B00	1.65 mm (0.0650 in.)
AK	23967-PL3-B00	1.68 mm (0.0661 in.)
AL	23968-PL3-B00	1.71 mm (0.0673 in.)
AM	23969-PL3-B00	1.74 mm (0.0685 in.)
AN	23970-PL3-B00	1.77 mm (0.0697 in.)
AO	23971-PL3-B00	1.80 mm (0.0709 in.)

6. Install the shim selected in the transmission housing as described below.

- a. Install the thrust washer and spring washer on the mainshaft.

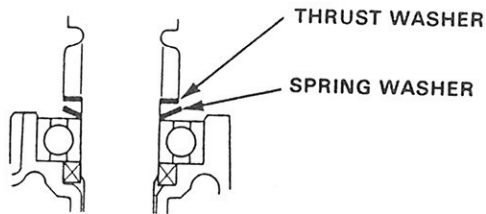

**NOTE:**

- Clean the thrust washer, spring washer and shim thoroughly before installation.
- Install the thrust washer, spring washer and shim properly.

- b. Install the mainshaft in the clutch housing.  
c. Place the transmission housing over the mainshaft and onto the clutch housing.  
d. Tighten the clutch and transmission housings with several 8 mm bolts.

7. Check the thrust clearance in the manner described below.

**NOTE:** Carry out the measurement at normal room temperature.

- a. Slide the mainshaft base over the mainshaft.

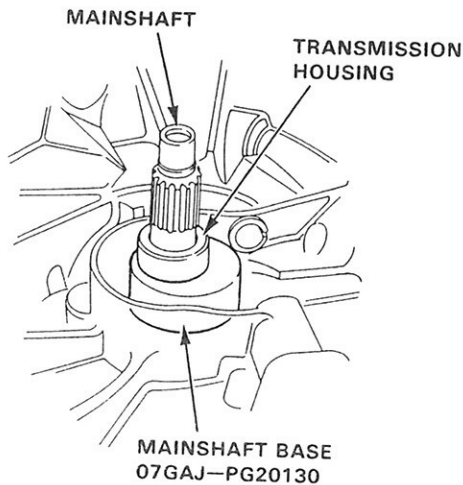

- b. Attach the mainshaft holder to the mainshaft as follows:

- Back-out the mainshaft holder bolt and loosen the two hex bolts.
- Fit the holder over the mainshaft so its lip is towards the transmission.
- Align the mainshaft holder's lip around the groove at the inside of the mainshaft splines, then tighten the hex bolts.

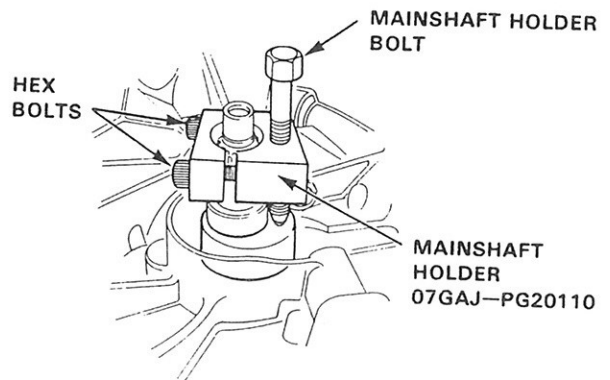

- c. Seat the mainshaft fully by tapping its end with a plastic hammer.  
d. Thread the mainshaft holder bolt in until it just contacts the wide surface of the mainshaft base.  
e. Zero a dial gauge on the end of the mainshaft.

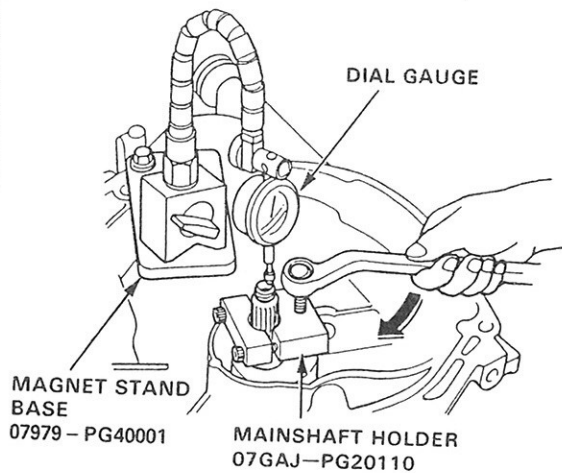

- f. Turn the mainshaft holder bolt clockwise; stop turning when the dial gauge has reached its maximum movement. The reading on the dial gauge is the amount of mainshaft end play.

**CAUTION:** Turning the shaft holder bolt more than 60 degrees after the needle of the dial gauge stops moving may damage the transmission.

- g. Clearance is correct if reading is between 0.11 – 0.18 mm (0.0043–0.0071 in).  
If not, recheck necessary shim thickness.

# Countershaft Assembly

## Index

### NOTE:

- The synchro springs are the same size.
- The 3rd, 4th and 5th gears are installed using a press.

 Prior to reassembling, clean all the parts in solvent, dry them and apply lubricant to any contact parts. The 3rd, 4th and 5th gears, should be installed using a press before lubricating them.

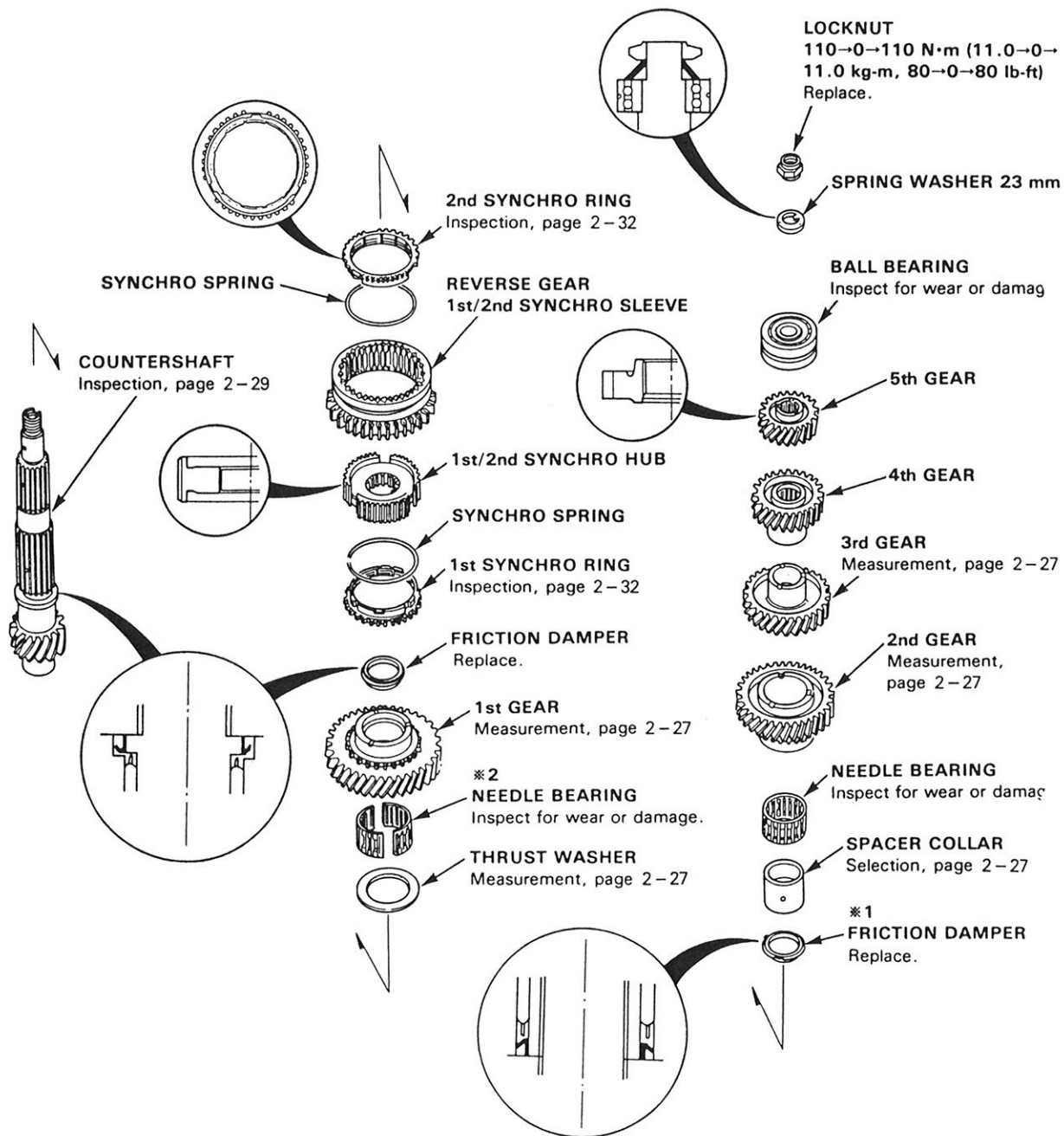

- ※1 Replace when removed from the distance collar.  
 ※2 Replace with a complete set of the same manufacturer.



## Clearance Inspection

1. Measure the clearance between 1st gear and the thrust washer.  
**Standard:** 0.04–0.12 mm (0.0016–0.0047 in.)  
**Service Limit:** 0.18 mm (0.0071 in.)

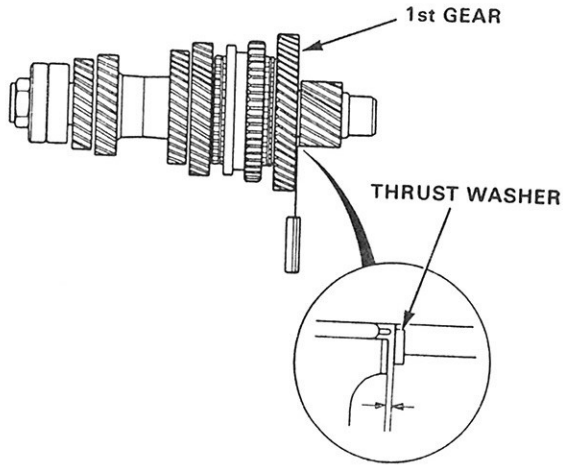

2. If the clearance exceeds the service limit, select the appropriate thrust washer for the correct clearance from the chart below.

	PART NUMBER	THICKNESS
A	23921-PK5-900	1.95 mm (0.0768 in.)
B	23922-PK5-900	1.96 mm (0.0772 in.)
C	23923-PK5-900	1.97 mm (0.0776 in.)
D	23924-PK5-900	1.98 mm (0.0780 in.)
E	23925-PK5-900	1.99 mm (0.0783 in.)
F	23926-PK5-900	2.00 mm (0.0787 in.)
G	23927-PK5-900	2.01 mm (0.0791 in.)
H	23928-PK5-900	2.02 mm (0.0795 in.)
I	23929-PK5-900	2.03 mm (0.0799 in.)
J	23930-PK5-900	2.04 mm (0.0803 in.)
K	23931-PK5-900	2.05 mm (0.0807 in.)
L	23932-PK5-900	2.06 mm (0.0811 in.)
M	23933-PK5-900	2.07 mm (0.0815 in.)
N	23934-PK5-900	2.08 mm (0.0819 in.)
O	23935-PK5-900	2.09 mm (0.0823 in.)
P	23936-PK5-900	2.10 mm (0.0827 in.)

3. Measure the clearance between the 2nd gear and 3rd gear.  
**Standard:** 0.05–0.12 mm (0.0020–0.0047 in.)  
**Service Limit:** 0.18 mm (0.0071 in.)

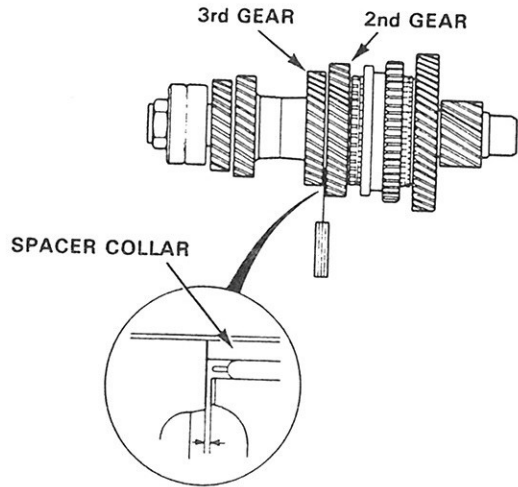

4. If the clearance exceeds the service limit, select the appropriate spacer collar for the correct clearance from the chart below.

	PART NUMBER	THICKNESS
A	23917-PS1-000	32.56–32.58 mm (1.2819–1.2827 in.)
B	23918-PS1-000	32.59–32.61 mm (1.2831–1.2839 in.)



# Countershaft Assembly

## Disassembly

1. Raise the locknut tab from the groove of the shaft and remove the locknut and the spring washer.

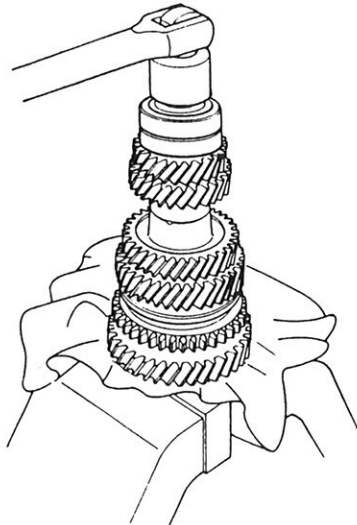

2. Remove the ball bearing using a bearing puller as shown.

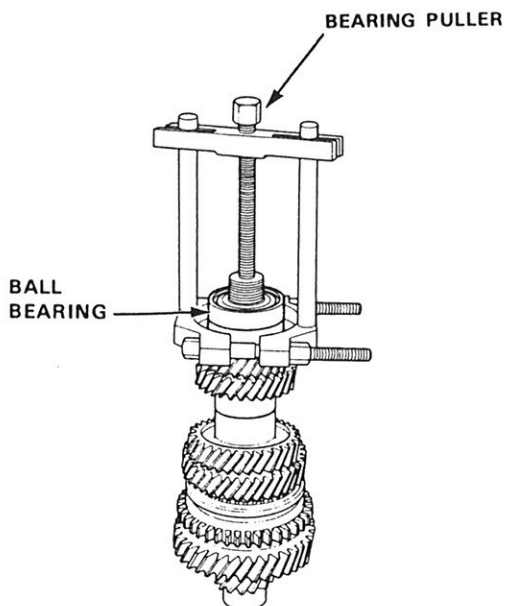

**CAUTION:** Remove the gears using a press and steel blocks as shown. Use of a jaw-type puller can cause damage to the gear teeth.

3. Support 4th gear on steel blocks as shown and press the shaft out of 4th and 5th gears.

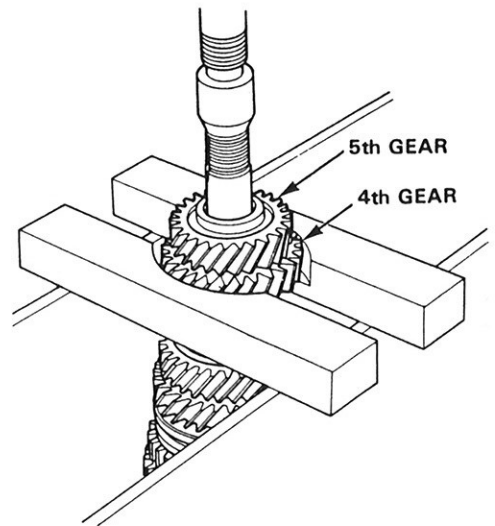

4. In the same manner as above, support 1st gear on steel blocks and press the shaft out of 3rd gear.

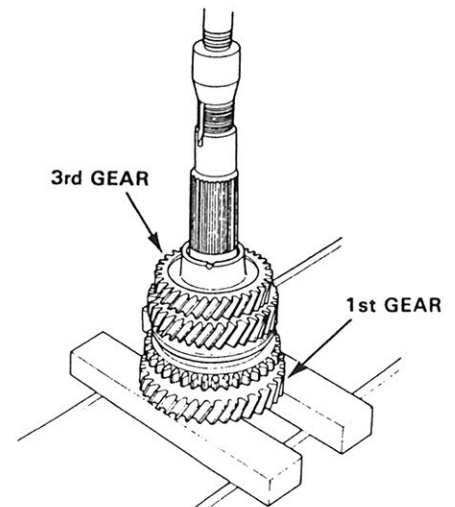

5. Using a press as shown, remove the friction damper from the spacer collar.

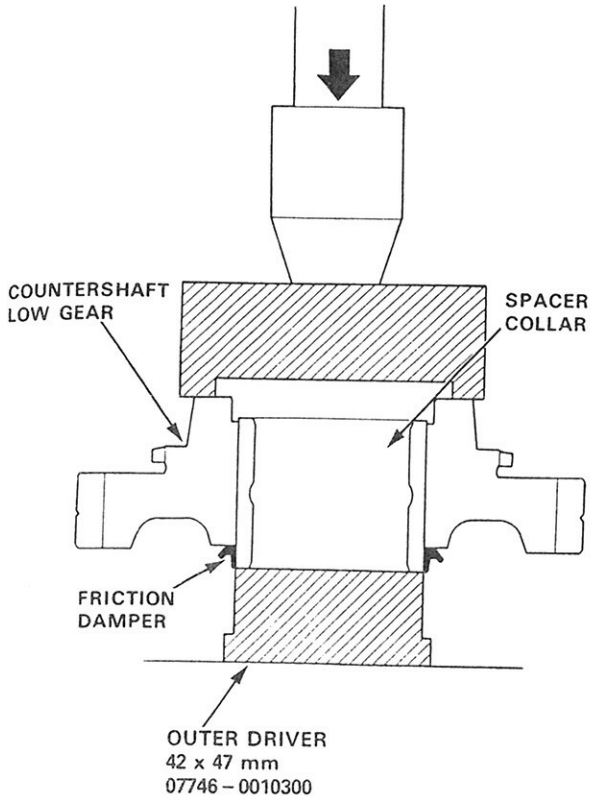

## Inspection

1. Measure the countershaft at points A, B and C.
- Standards:**
- A: Roller bearing surface**  
33.000–33.015 mm  
(1.299–1.300 in.)
  - B: Needle bearing surface**  
36.984–37.000 mm  
(1.456–1.457 in.)
  - C: Ball bearing surface**  
24.987–25.000 mm  
(0.984–0.984 in.)
- Service Limits:**
- A: 32.95 mm (1.297 in.)**
  - B: 36.93 mm (1.454 in.)**
  - C: 24.94 mm (0.982 in.)**

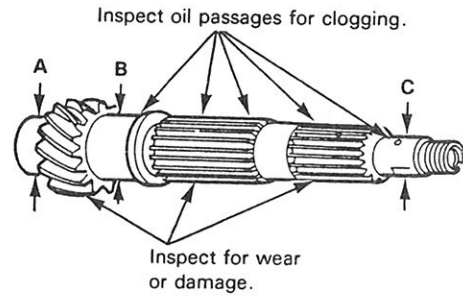

Replace the countershaft if any part of it is less than the service limit.

2. Inspect for runout.
- Standard:** 0.02 mm (0.0008 in.)
- Service Limit:** 0.05 mm (0.0020 in.)

**NOTE:** Support the countershaft at the A and B points as shown.

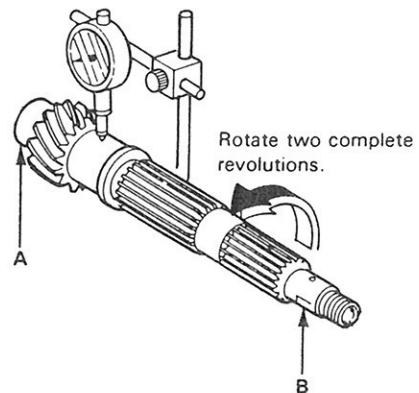

Replace the countershaft if the runout exceeds the service limit.

# Countershaft Assembly

## Reassembly

### CAUTION:

- Install the 3rd, 4th and 5th gears using a press before applying any lubricant to them.
- When installing the 3rd, 4th and 5th gears, support the shaft on steel blocks and install gears using a press.
- Install the 3rd, 4th and 5th gears by the pressure (stable load) of 2,600 kg.

1. Using a press, install the friction damper to the spacer collar.

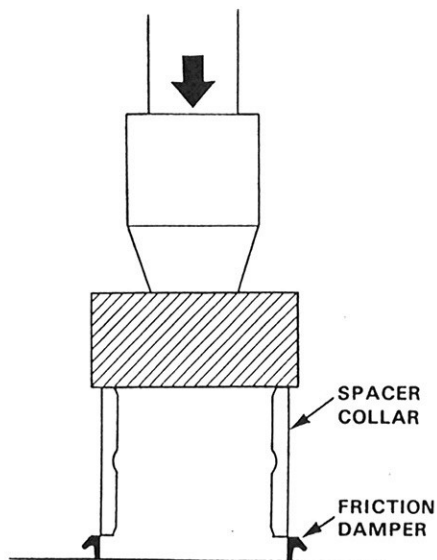

2. Support the countershaft on a steel block as shown and install 3rd gear using a press.

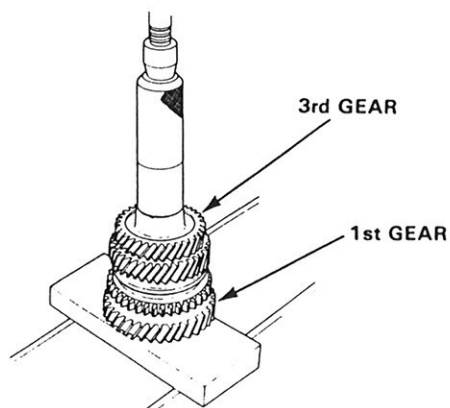

3. Install 4th gear using a press as shown.

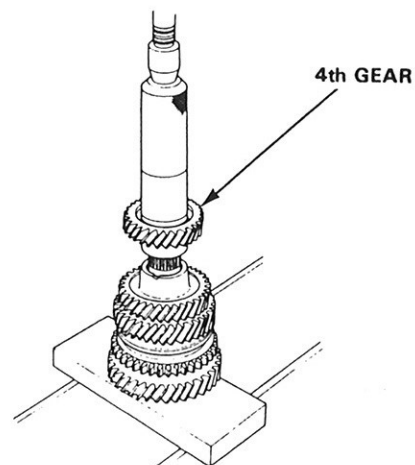

4. Install 5th gear using a press as shown.

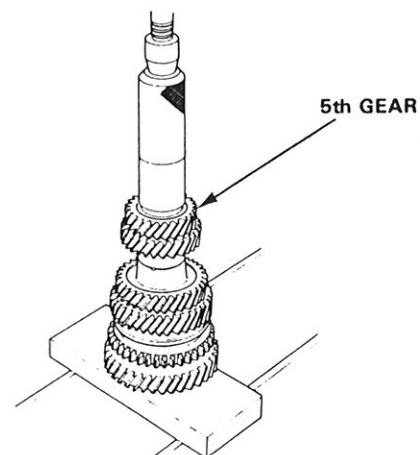

5. Install the ball bearing using a press as shown.

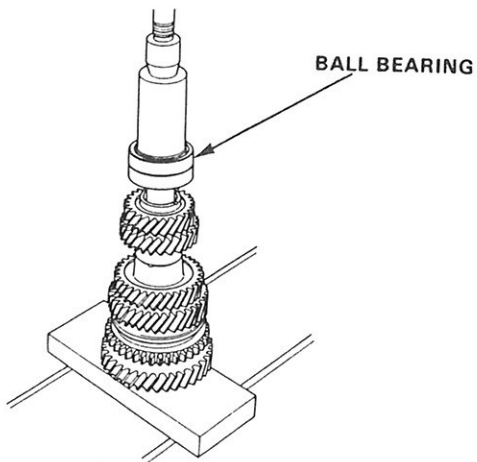

6. Install the spring washer, tighten the locknut and then stake the locknut tab into the groove.

**LOCKNUT**  
110 → 0 → 110 N·m (11.0 → 0 → 11.0 kg·m,  
80 → 0 → 80 lb-ft)

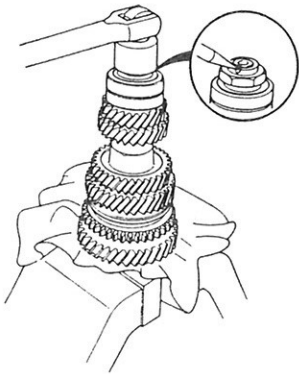

# Synchro Ring, Gear

## Inspection

1. Inspect the inside of the synchro ring for wear.
2. Inspect the synchro sleeve teeth and matching teeth on the synchro ring for wear (rounded off).



GOOD WORN

SYNCHRO RING

SYNCHRO SPRING

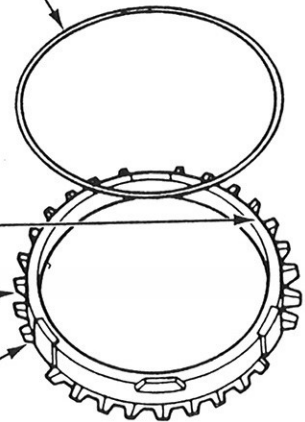

3. Inspect the synchro sleeve teeth and matching teeth on the gear for wear (rounded off).

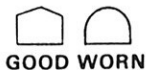

GOOD WORN

4. Inspect the gear hub thrust surface for wear.
5. Inspect the cone surface for wear or roughness.
6. Inspect the teeth on all gears for uneven wear, scoring, galling, cracks.

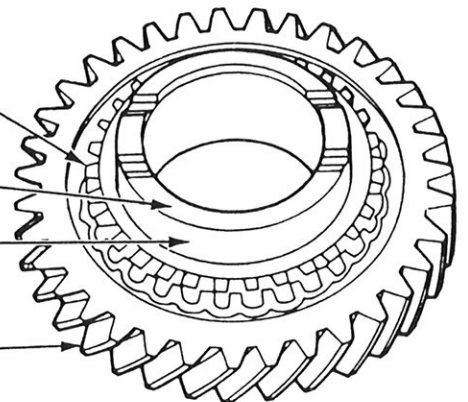

7. Coat the cone surface of the gear with oil and place the synchro ring on the matching gear. Rotate the ring, making sure that it does not slip.

Measure the clearance between the ring and gear all the way around.

NOTE: Hold the ring against the gear evenly while measuring the clearance.

### Ring-to-Gear Clearance

Standard: 0.85–1.1 mm (0.033–0.043 in.)

Service Limit: 0.4 mm (0.016 in.)

8. Separate the synchro ring and gear, then coat them with oil.
9. Install the synchro spring on the synchro ring, then set it aside for later reassembly.

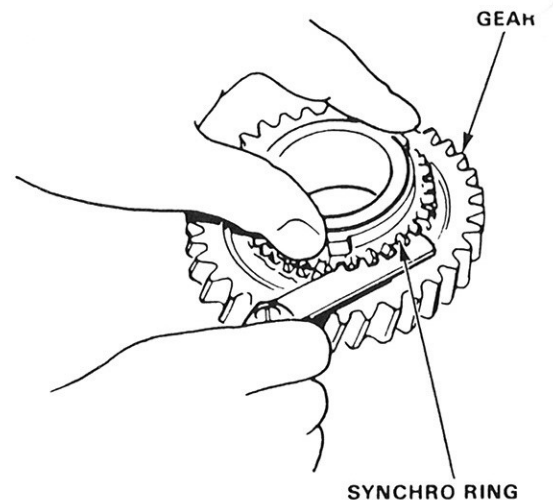

# Synchro Sleeve, Synchro Hub

## Inspection

1. Inspect gear teeth on all synchro hubs and sleeves for rounded off corners, which indicates wear.
2. Install each hub in its mating sleeve and check for freedom of movement.

NOTE: If replacement is required, always replace the synchro sleeve and hub as a unit.

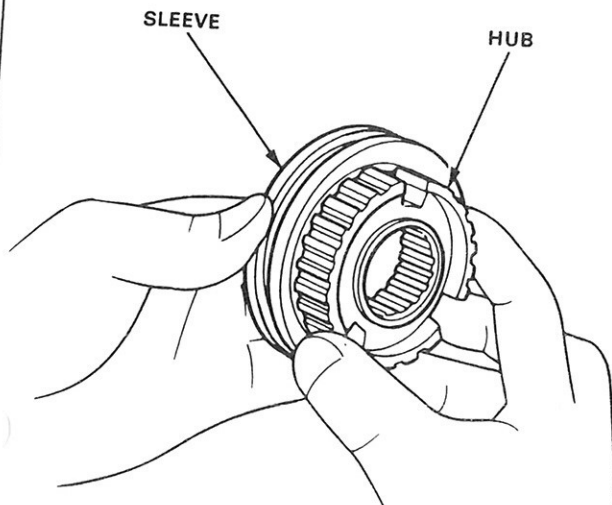

## Installation

Each synchro sleeve has three sets of longer teeth (120 degrees apart) that must be matched with the three sets of deeper grooves in the hub when assembled.

NOTE: Installing the synchro sleeve with its longer teeth in the 1st/2nd synchro hub slots will damage the spring ring.

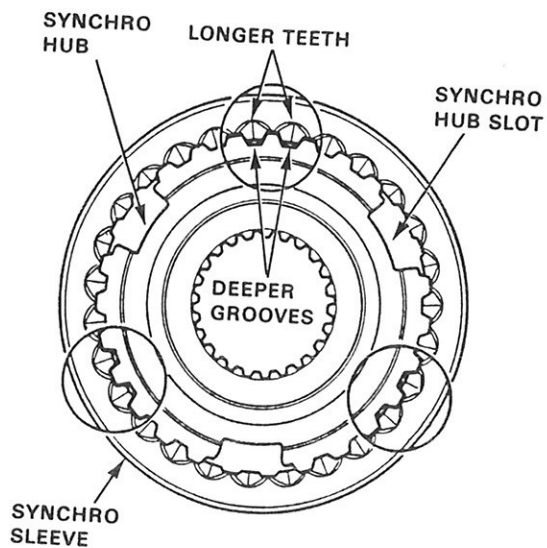

# Transmission

## Reassembly

1. Drive the oil seal into the clutch housing.
2. Set the shift rod guide, then install the shift rod with its detent hole up.
3. Install the boot so that its hole faces downward when the transmission is mounted on the vehicle.

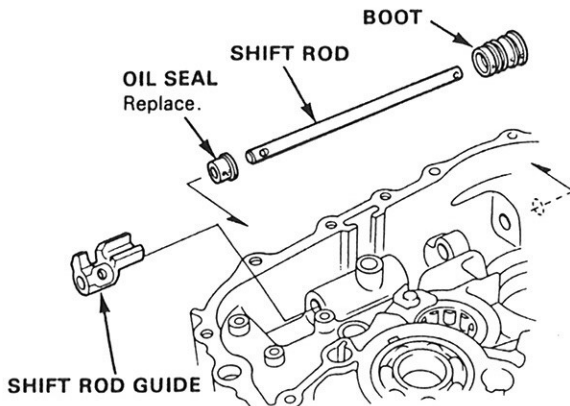

4. Grease the steel ball and spring, then install them.
5. Install the bolt and washer holding the shift rod guide.

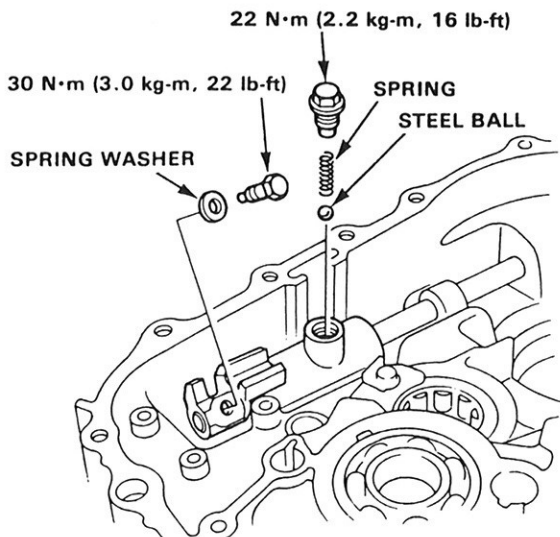

6. Install the differential assembly in the clutch housing.

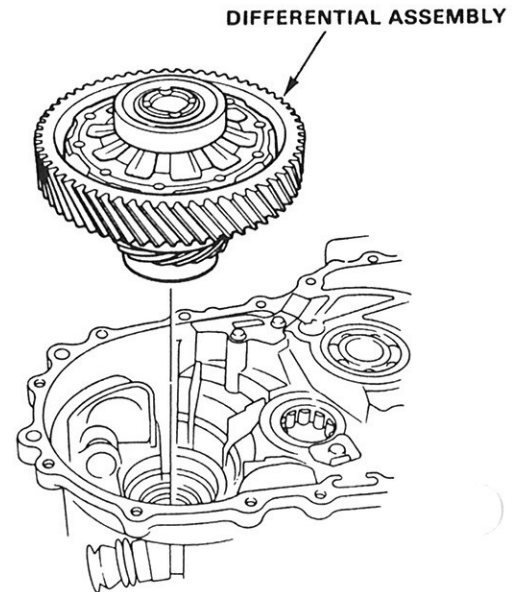

7. Install the spring washer and thrust washer with the angle against the clutch housing as shown below.
8. Insert the mainshaft and countershaft into the shift forks and install them as an assembly.

NOTE: Tape the mainshaft splines, before installation

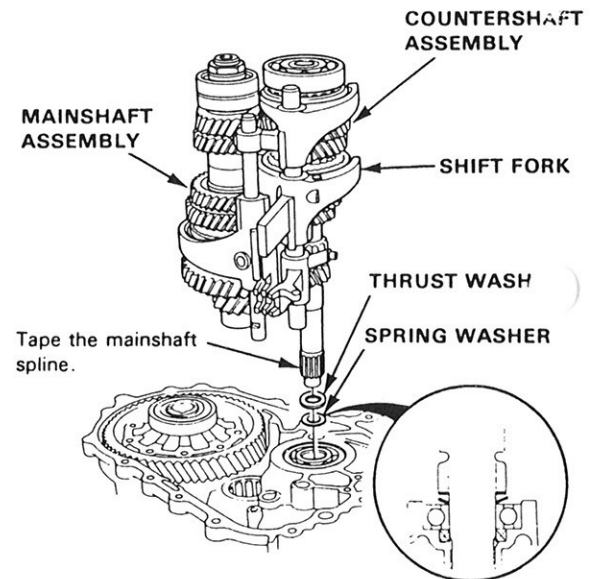



ch housing.

SEMBLY

9. Install the shift arm holder assembly in the clutch housing.

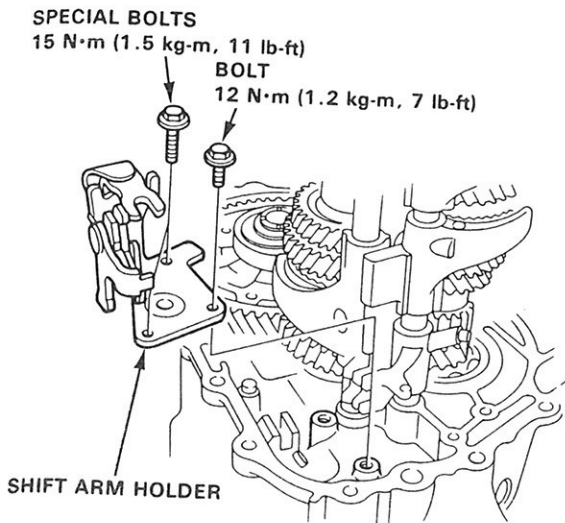

10. Assemble the shift guide and interlock, then insert the shift guide shaft.

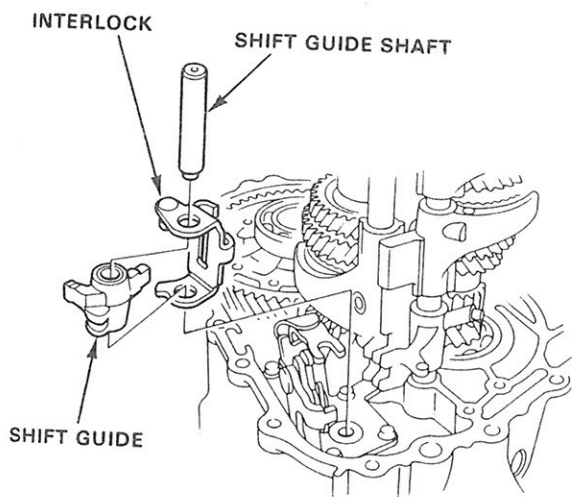

11. Measure the distance  $\textcircled{A}$  after mounting the shift guide shaft. If not correct, check installation.  
Distance A  
Standard: 11.9–12.3 mm  
(0.468–0.484 in)

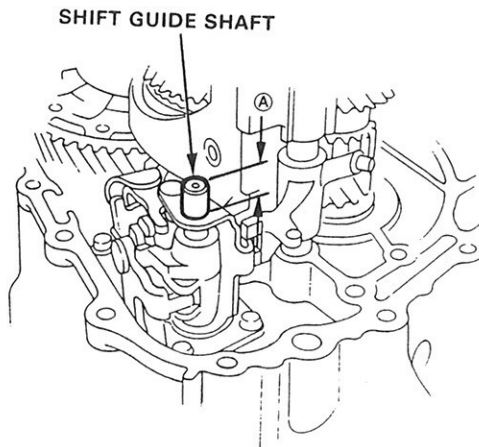

12. Install the reverse idle gear and idle gear shaft in the clutch housing.

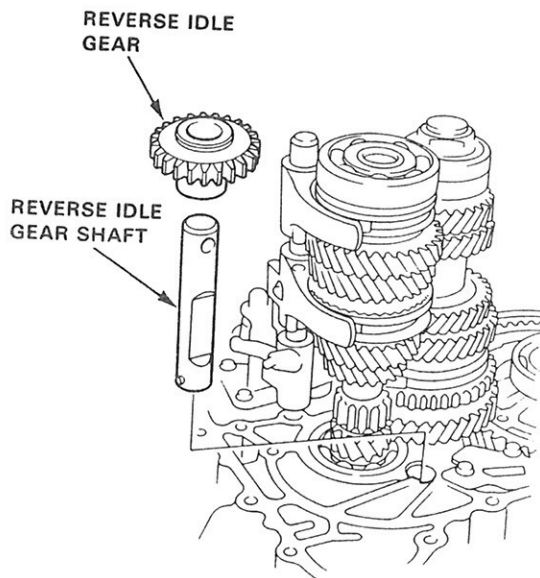

(cont'd)

with the  
low.  
he shift

illation.

AFT

K

# Transmission

## Reassembly (cont'd)

13. Install the reverse shift fork in the clutch housing with the 5th/reverse shift piece pin matching the L-groove of the reverse shift fork.

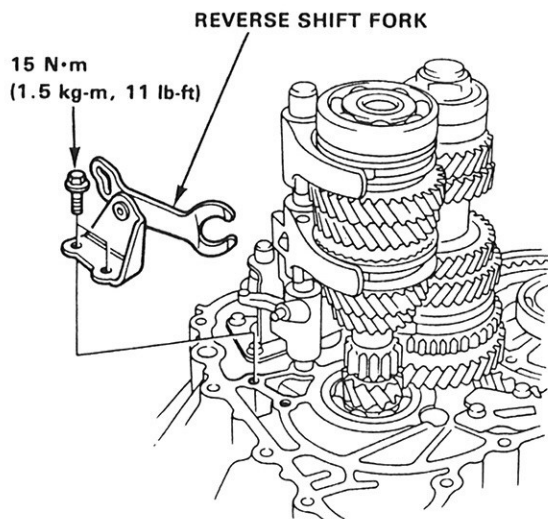

14. Install the oil guide plate and mainshaft thrust shim into the transmission housing.  
NOTE: Select the mainshaft thrust shim according to the measurements made on page 2-24.

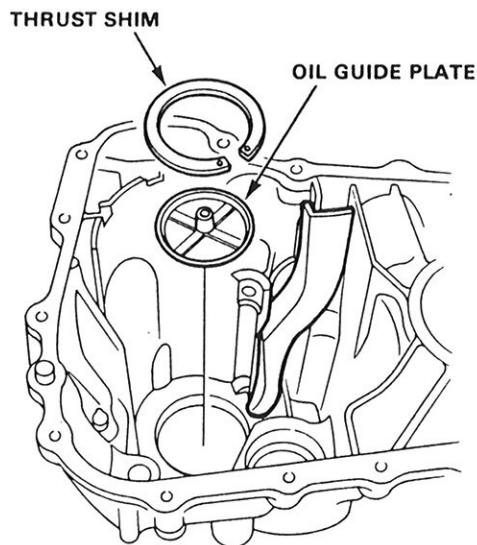

15. Apply liquid gasket to the transmission mating surface of the clutch housing.

NOTE: This transmission uses no gasket between the major housings; use Honda Genuine liquid gasket (P/N OY740-99986). Assemble the housings within 20 minutes after applying the liquid gasket and allow it to cure at least 30 minutes after assembly before filling it with oil.

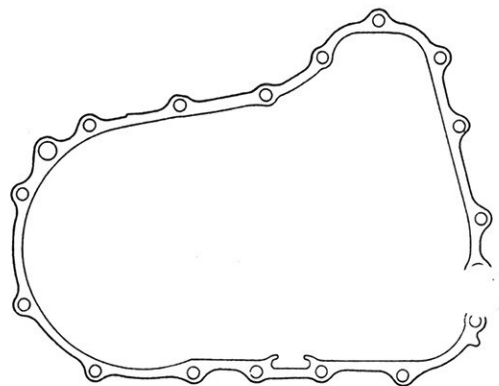

16. Install the dowel pins on the clutch housing.  
17. Place the transmission housing over the clutch housing, being careful to line up the shafts.

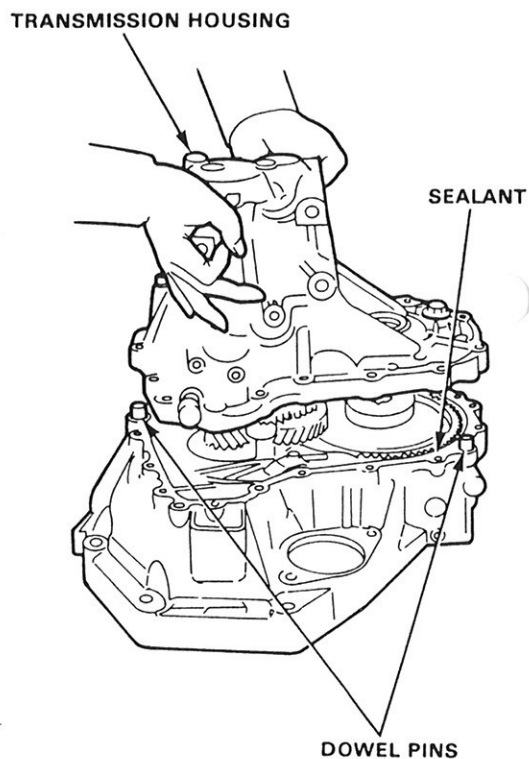

18. Lower the transmission housing with the snap ring expanded and set the snap ring in the groove of the countershaft bearing.

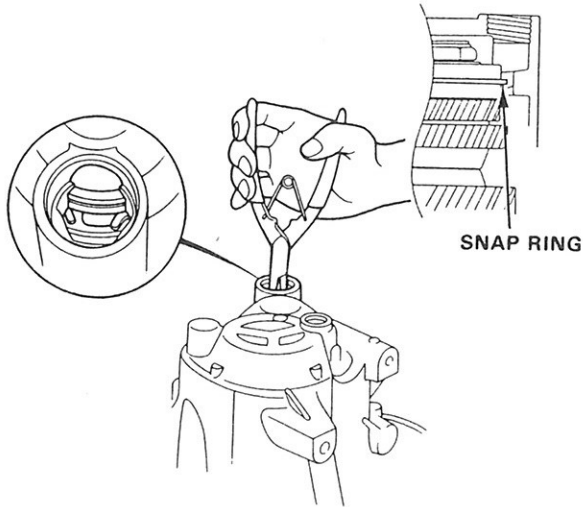

19. Check that the snap ring is securely seated in the groove of the countershaft bearing.

Dimension A as installed
4.56—9.71 mm (0.180—0.382 in.)

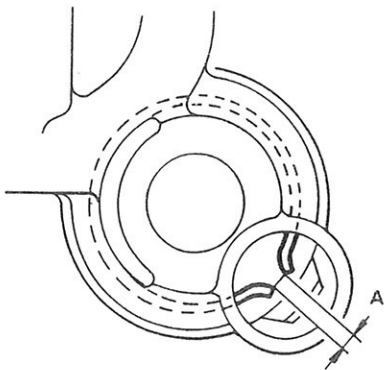

20. Torque the transmission housing attaching bolts in the numbered sequence shown below.  
 21. Install the 32 mm sealing bolt.  
 NOTE: Apply Honda Genuine liquid gasket (P/N OY740-99986) to the threads.  
 22. Install the reverse idle gear shaft bolt.  
 23. Install the clutch cable bracket.  
 24. Install the back-up light switch.

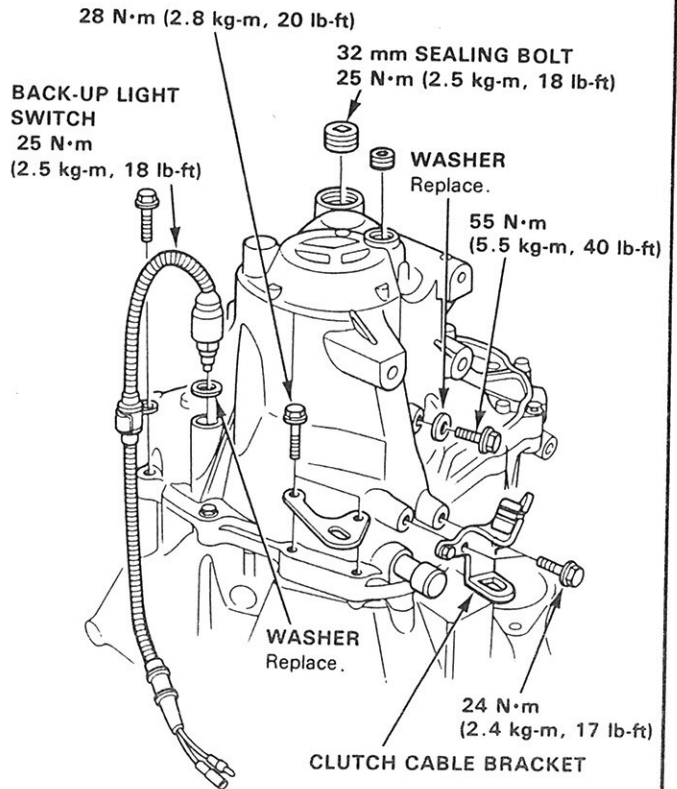

28 N·m (2.8 kg-m, 20 lb-ft)

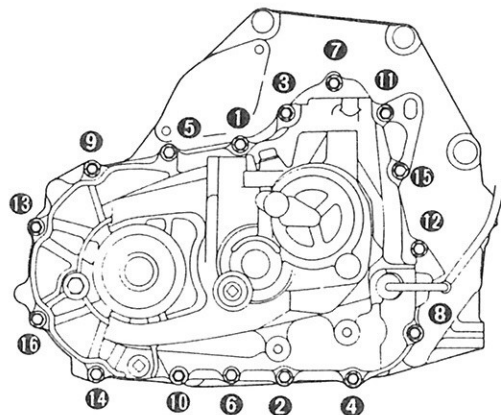

|

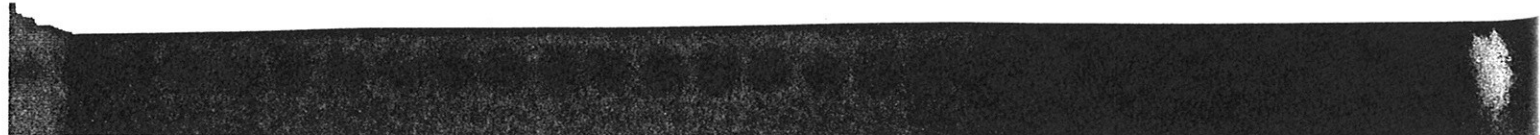

## Differential

### Service Specifications/Special Tools

Service Specifications .....	3-2
Special Tools .....	3-2

### Differential

Illustrated Index .....	3-3
Backlash Inspection .....	3-4
Bearing Replacement .....	3-4
Inspection/Disassembly .....	3-5
Reassembly .....	3-6
Oil Seal Removal .....	3-7
Thrust Shim Adjustment .....	3-8
Oil Seal Installation .....	3-9

# Service Specifications/Special Tools

Unit of length: r n.)

## Service Specifications

	MEASUREMENT	STANDARD (NEW)	SERVICE LIMIT
Ring gear	Backlash	0.085—0.142 (0.003—0.006)	0.200 (0.008)
Differential carrier	Pinion shaft bore diameter	18.000—18.016 (0.7087—0.7093)	—
	Carrier-to-pinion shaft clearance	0.017—0.045 (0.001—0.002)	0.100 (0.004)
	Driveshaft bore diameter	28.000—28.021 (1.102—1.103)	—
	Carrier-to-driveshaft clearance	0.020—0.062 (0.001—0.002)	0.120 (0.005)
	Carrier-to-intermediate shaft clearance	0.050—0.087 (0.002—0.003)	0.140 (0.006)
	Side clearance	below 0.10 (0.004)	Adjust with a shim
Differential pinion gear	Backlash	0.05—0.15 (0.002—0.006)	Adjust with a washer
	Pinion gear bore diameter	18.042—18.066 (0.710—0.711)	—
	Pinion gear-to-pinion shaft clearance	0.059—0.095 (0.002—0.004)	0.150 (0.006)

## Special Tools

Ref. No.	Tool No.	Description	Qty	Remarks
①	07746—0030100	Inner Handle C	1	
②	07944—SA00000	Pin Driver, 4.0 mm	1	
③	07749—0010000	Outer Handle A	1	
④	07947—SD90200	Oil Seal Driver Attachment	1	
⑤	07JAD—PH80400	Pilot Driver, 28 x 30 mm	1	
⑥	07GAD—PG40100	Oil Seal Driver	1	

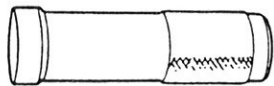

①



②



③

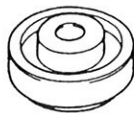

④



⑤

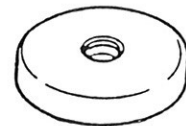

⑥

# Differential Illustrated Index

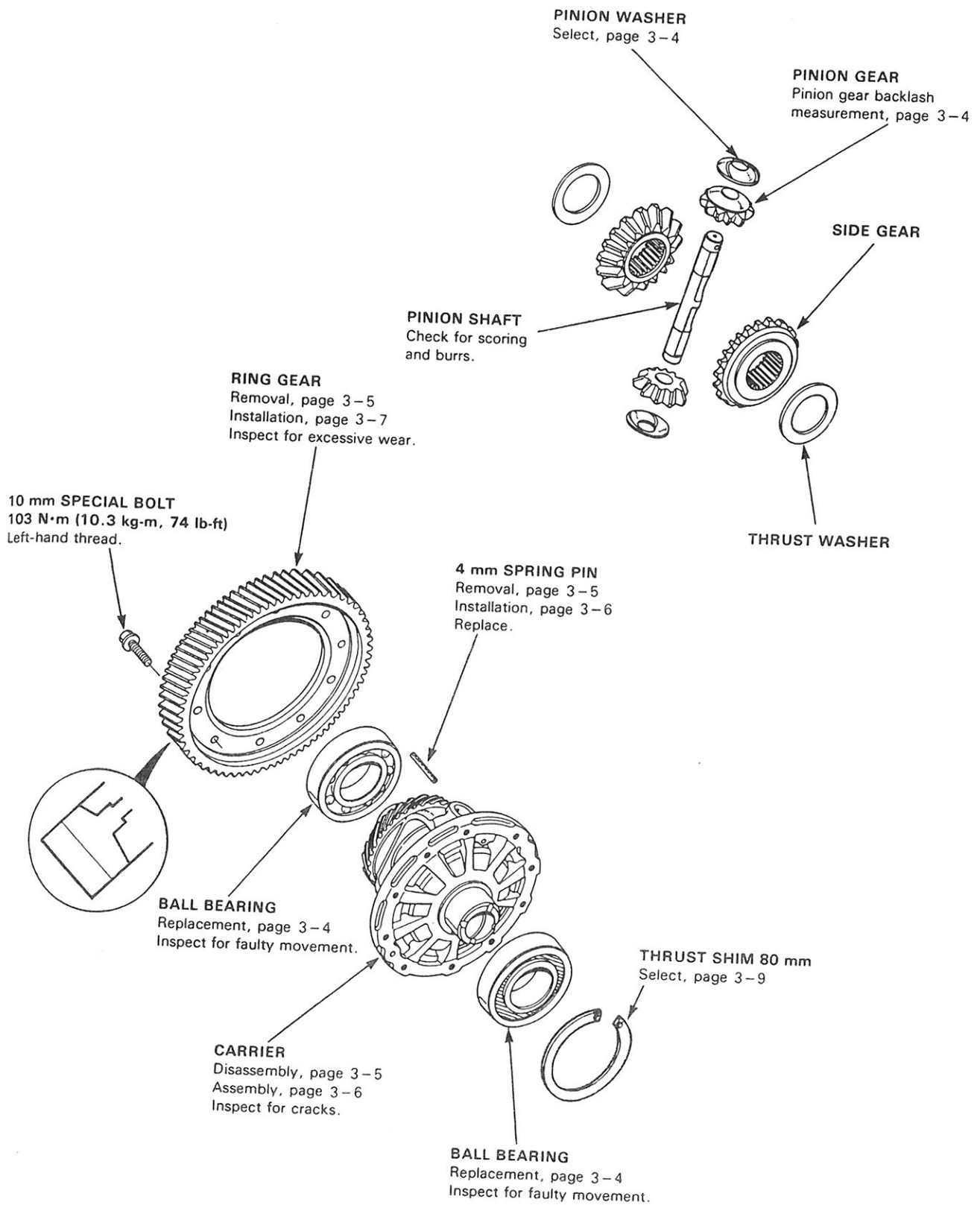



## Differential

### Backlash Inspection

1. Place the differential assembly on V-blocks and install both axles.
2. Check backlash of both pinion gears.

**Standard (New):** 0.05–0.15 mm  
(0.002–0.006 in.)

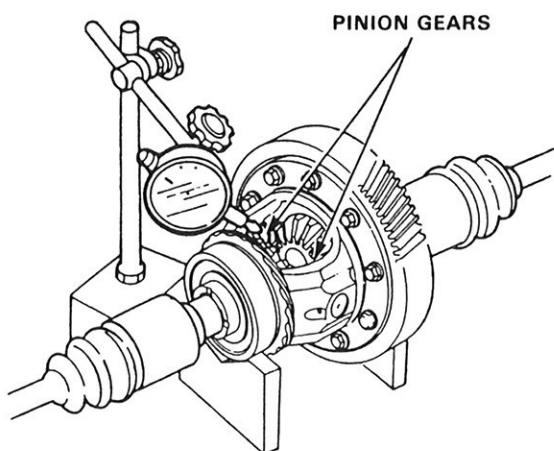

3. If out of tolerance, disassemble the differential and select new pinion washers from the table below.

PART NUMBER	THICKNESS
41351-689-000	0.7 mm (0.028 in.)
41352-689-000	0.8 mm (0.031 in.)
41353-689-000	0.9 mm (0.035 in.)
41354-689-000	1.0 mm (0.039 in.)
41355-PC8-000	0.75 mm (0.030 in.)
41356-PC8-000	0.85 mm (0.033 in.)
41357-PC8-000	0.95 mm (0.037 in.)

### Bearing Replacement

NOTE: Check the bearings for wear and rough rotation. If bearings are OK, removal is not necessary.

1. Remove bearing using a standard bearing puller.

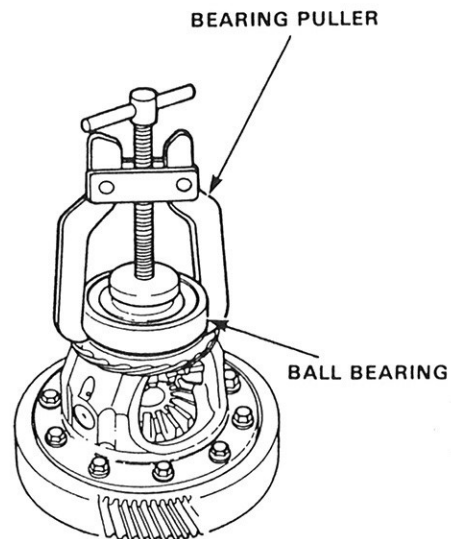

2. Install new bearing with the shielded side facing out using the special tool.

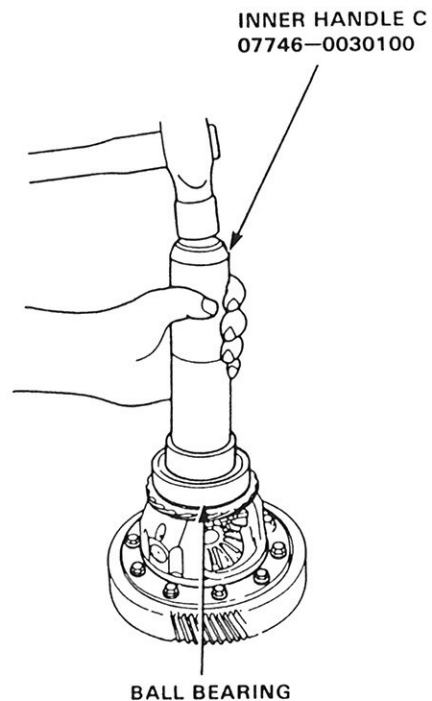

## Inspection/Disassembly

1. Remove ring gear and inspect teeth for wear or damage.

**CAUTION:** The ring gear bolts have left-hand threads.

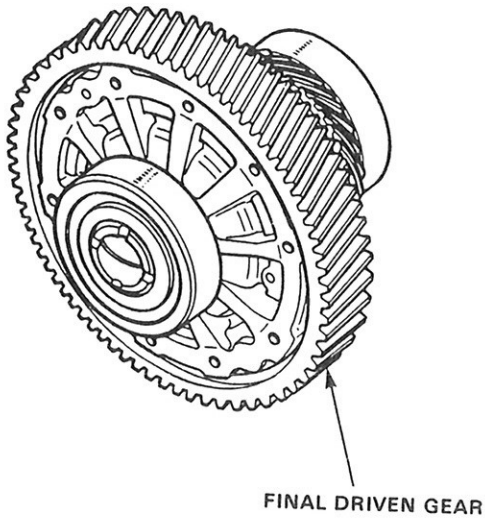

2. Drive out 4 mm spring pin with the pin driver.

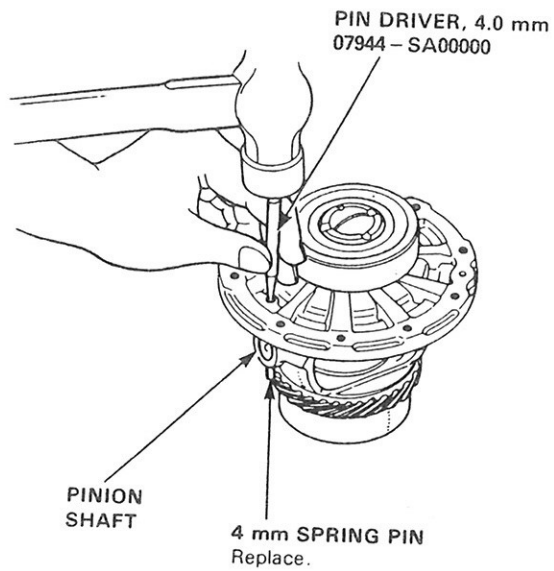

3. Remove the pinion shaft, pinion gears, washers, side gears and thrust washers.

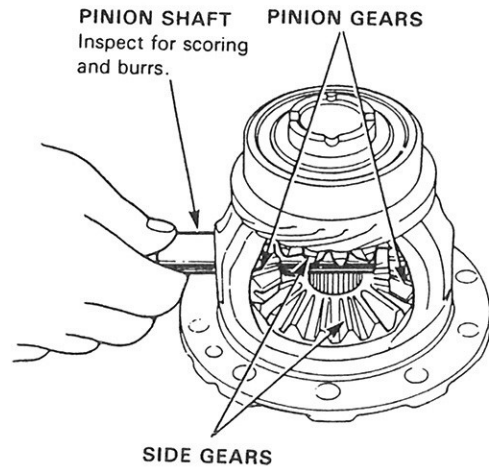

4. Wash the parts thoroughly in solvent and dry them with compressed air. Inspect all parts for wear or damage and replace any that are defective.

# Differential

## Reassembly

1. Install the side gears and thrust washers in the differential carrier.

**CAUTION:** Coat all gears with molybdenum disulfide grease on all sides.

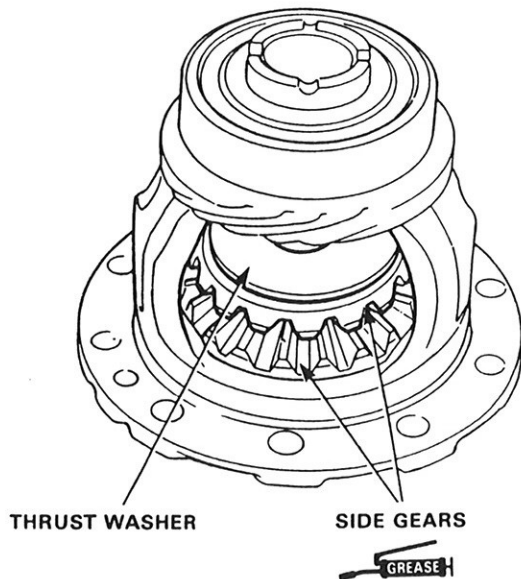

2. Set pinion gears in place exactly opposite each other in mesh with side gears, then install a pinion washer behind each one. Washers must be of equal thickness.

**NOTE:** Select the correct pinion washer from the table on page 3-4.

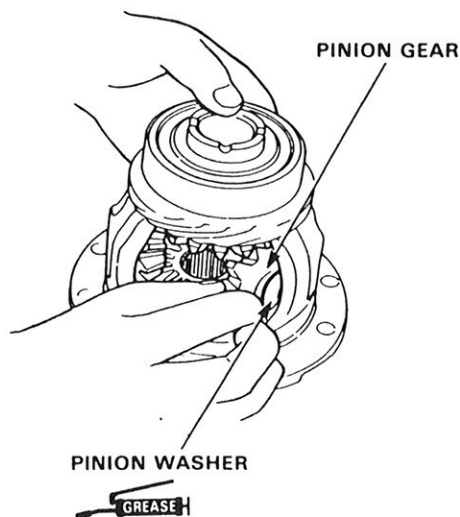

3. Rotate gears as shown until shaft holes in pinion gears line up with shaft holes in carrier.
4. Insert pinion shaft and align spring pin holes in one end with matching hole in carrier.

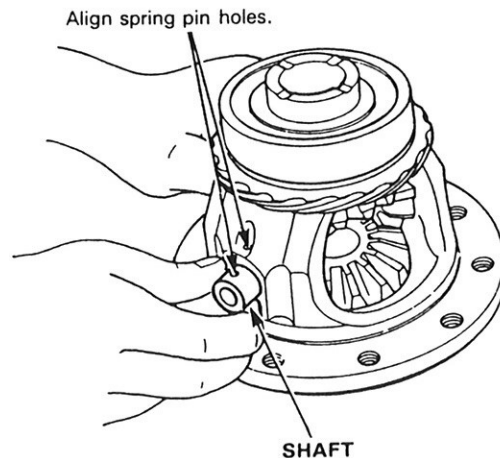

5. Drive in a new 4 mm spring pin with the pin driver.

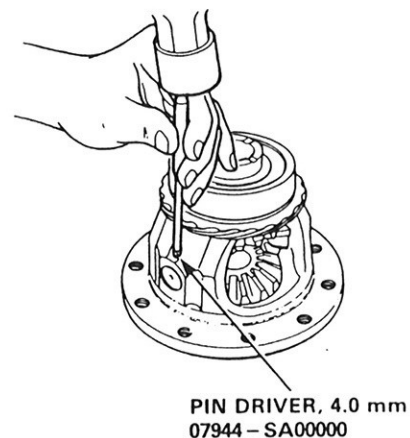

6. Check backlash of both pinion gears again.

**Standard (New):** 0.05–0.15 mm  
(0.002–0.006 in.)

- If still out of tolerance, replace both pinion gears, then recheck backlash.
- If still out of tolerance, replace side gears, and recheck backlash.
- If still out of tolerance, replace carrier assembly.

7. Install the ring gear. Torque the bolts to 103 N·m (10.3 kg-m, 74 lb-ft).

**CAUTION:** The ring gear bolts have left-hand threads.

Chamfer on inside diameter of ring gear faces carrier.

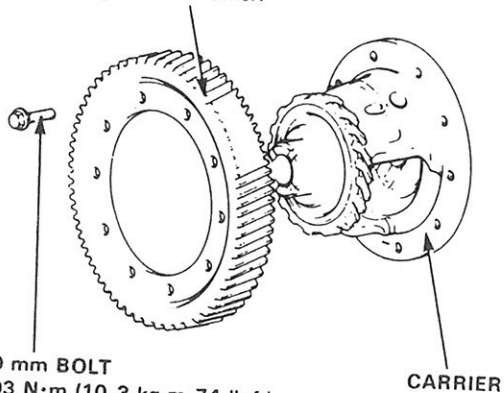

10 mm BOLT  
103 N·m (10.3 kg-m, 74 lb-ft)  
Left-hand threads.

## Oil Seal Removal

1. Remove the thrust shim from the transmission housing.

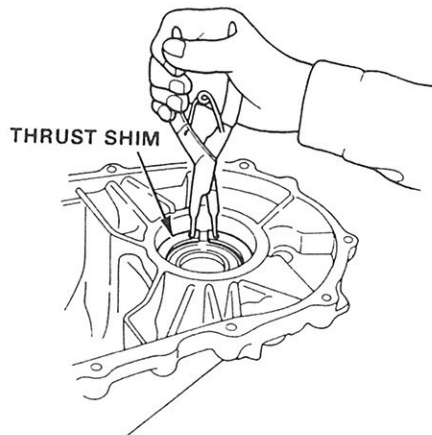

2. Remove the oil seal from the transmission housing.

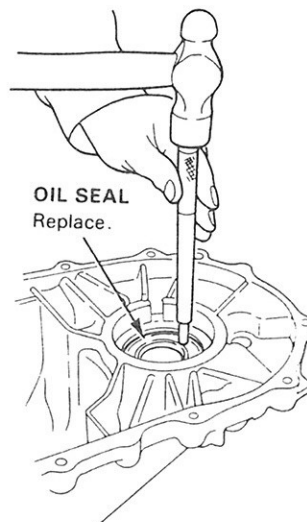

3. Remove the oil seal from the clutch housing.

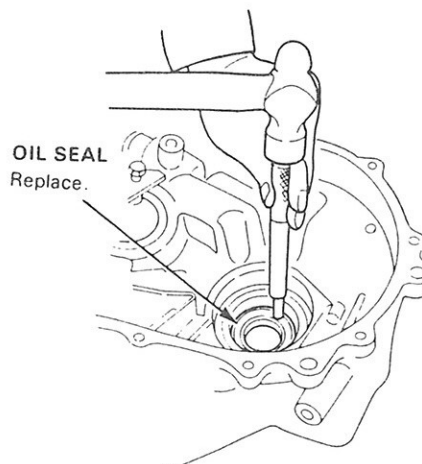

# Differential

## Thrust Shim Adjustment

1. Install the differential assembly into clutch housing using the special tool.

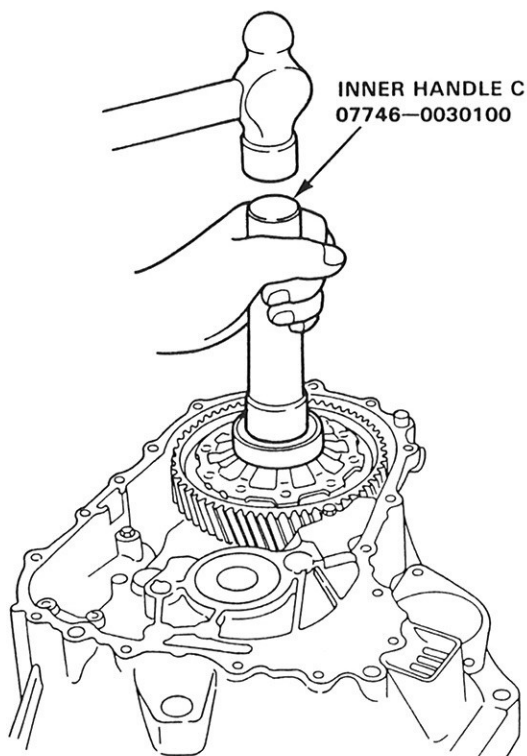

2. First try a 1.00 mm (0.03937 in) thrust shim.

**CAUTION:** Do not use more than two shims.

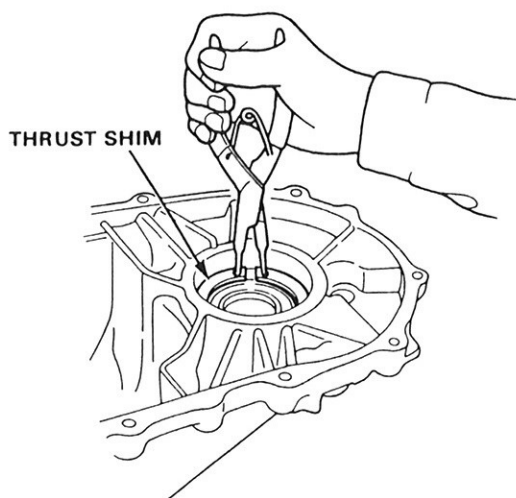

3. Install the transmission housing (see section 2).  
NOTE: Do not apply liquid gasket to the mating surface of the clutch housing yet.
4. Tighten the transmission bolts (see section 2).
5. Bottom the differential assembly in clutch housing using the special tool.

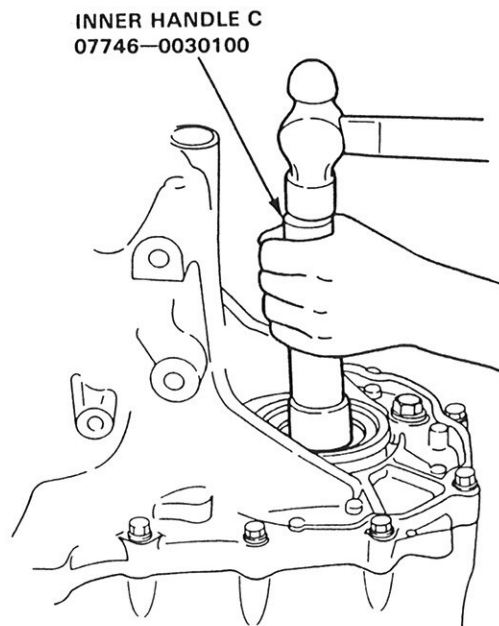

6. Measure clearance between thrust shim and outer race of bearing in transmission housing.

**Side Clearance: 0.10 mm (0.03937 in.) Max.**

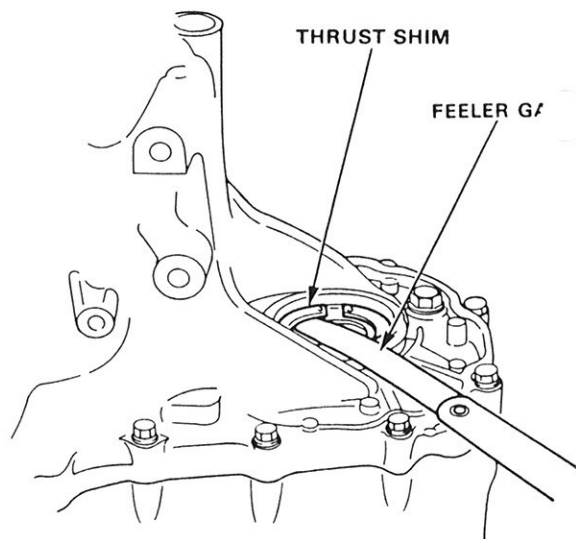

If out of tolerance, select a new thrust shim from the following table and install:

**80 mm Thrust Shim**

PART NUMBER	THICKNESS
41441-PL3-B00	1.0 mm (0.03937 in.)
41442-PL3-B00	1.1 mm (0.04331 in.)
41443-PL3-B00	1.2 mm (0.04724 in.)
41444-PL3-B00	1.3 mm (0.05118 in.)
41445-PL3-B00	1.4 mm (0.05512 in.)
41446-PL3-B00	1.5 mm (0.05906 in.)
41447-PL3-B00	1.6 mm (0.06299 in.)
41448-PL3-B00	1.7 mm (0.06693 in.)
41449-PL3-B00	1.8 mm (0.07087 in.)
41450-PL3-B00	1.05 mm (0.04134 in.)
41451-PL3-B00	1.15 mm (0.04528 in.)
41452-PL3-B00	1.25 mm (0.04921 in.)
41453-PL3-B00	1.35 mm (0.05315 in.)
41454-PL3-B00	1.45 mm (0.05709 in.)
41455-PL3-B00	1.55 mm (0.06102 in.)
41456-PL3-B00	1.65 mm (0.06496 in.)
41457-PL3-B00	1.75 mm (0.06890 in.)

- Remove the bolts and transmission housing (see section 2).
- Replace the 1 mm (0.03937 in) shim with the one of the correct thickness selected in the step 6.

**NOTE:** If the shim-to-bearing clearance calculated in the step 6 is less than the specification, it is not necessary to replace the shim.

- Reassemble the transmission and install the transmission housing (see section 2).

**Oil Seal Installation**

- Install the oil seal into the transmission housing using the special tools.

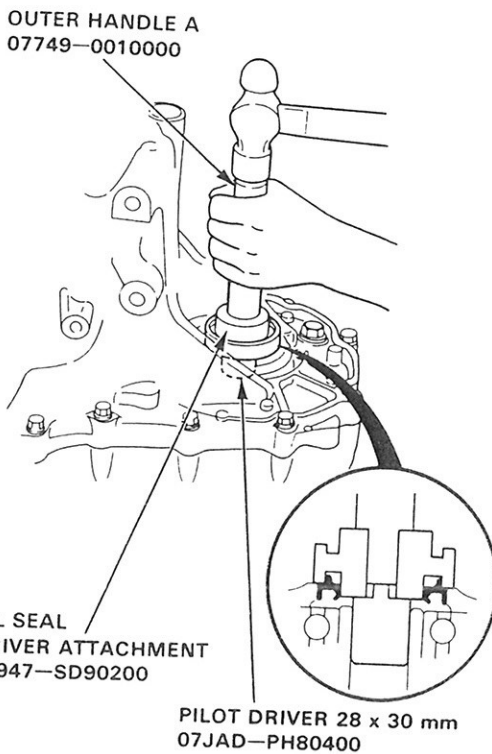

- Install the oil seal into the clutch housing using the special tools.

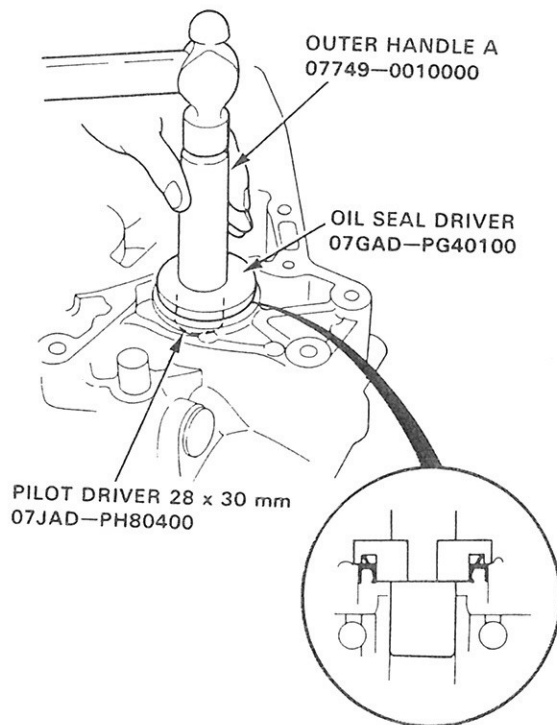







# HONDA

HONDA MOTOR CO., LTD. TOKYO, JAPAN