

57-03

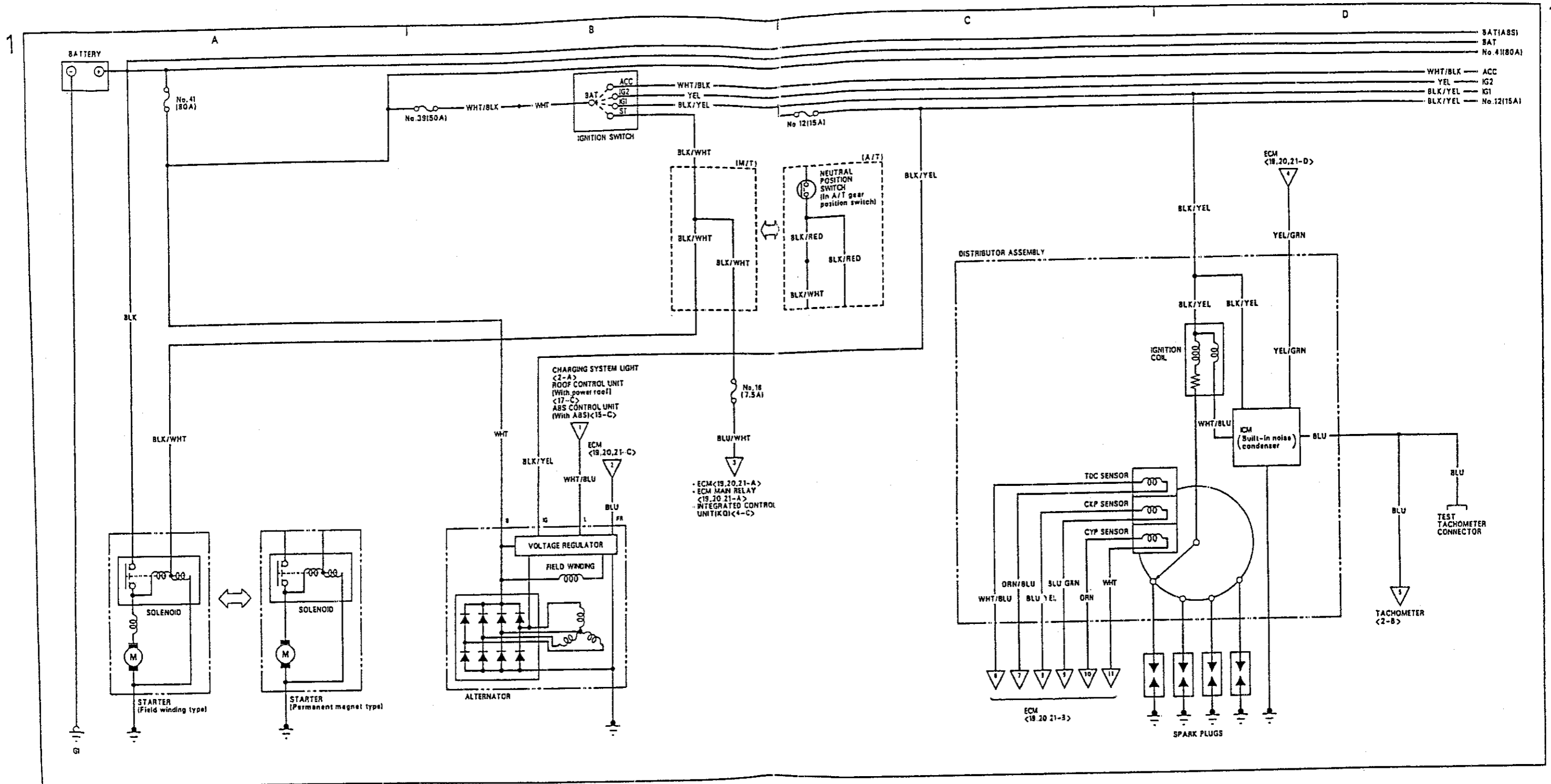

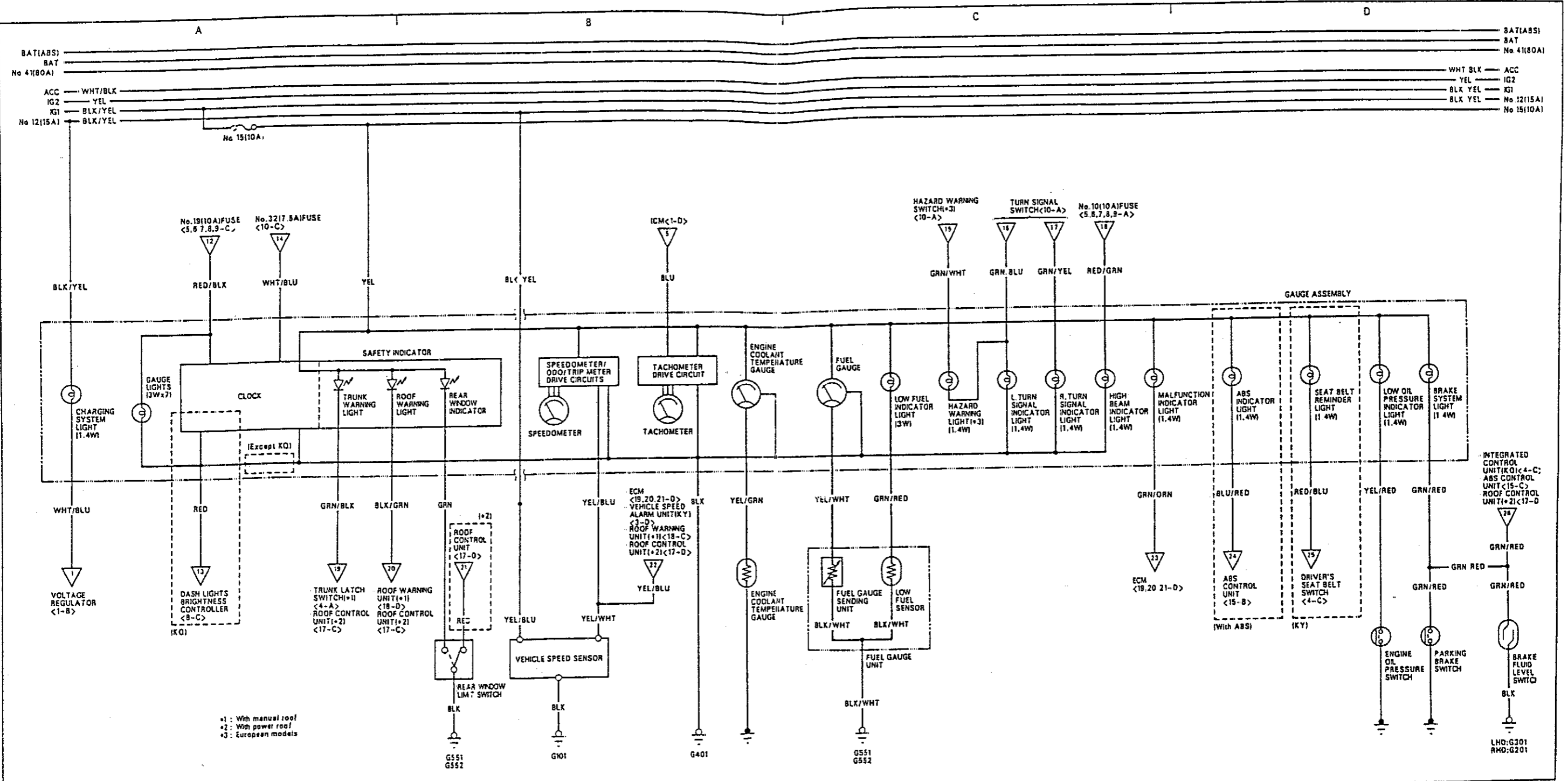

1: With manual roof
 2: With power roof
 3: European models

LHD:G301
 RHD:G201

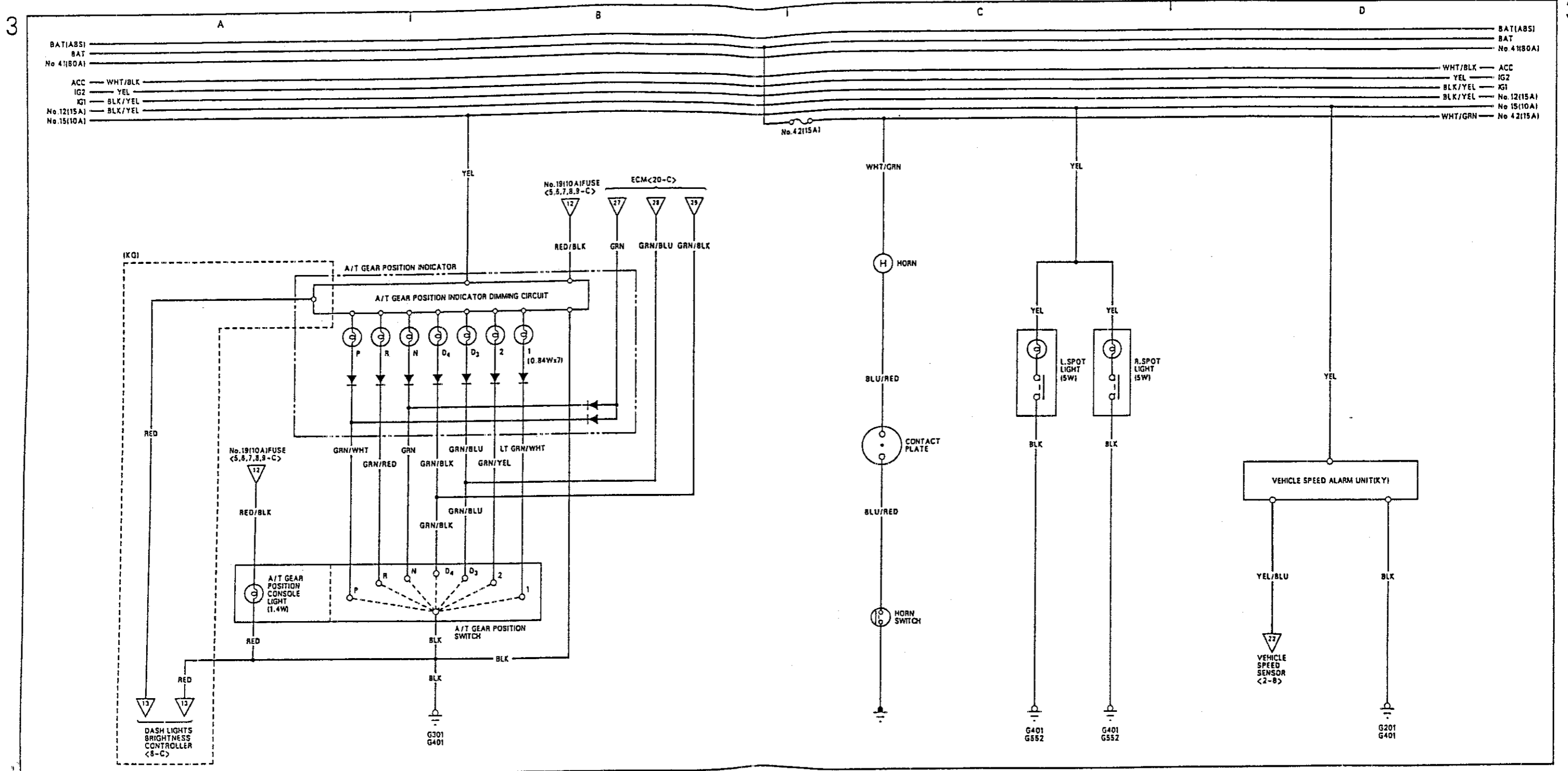

3

3

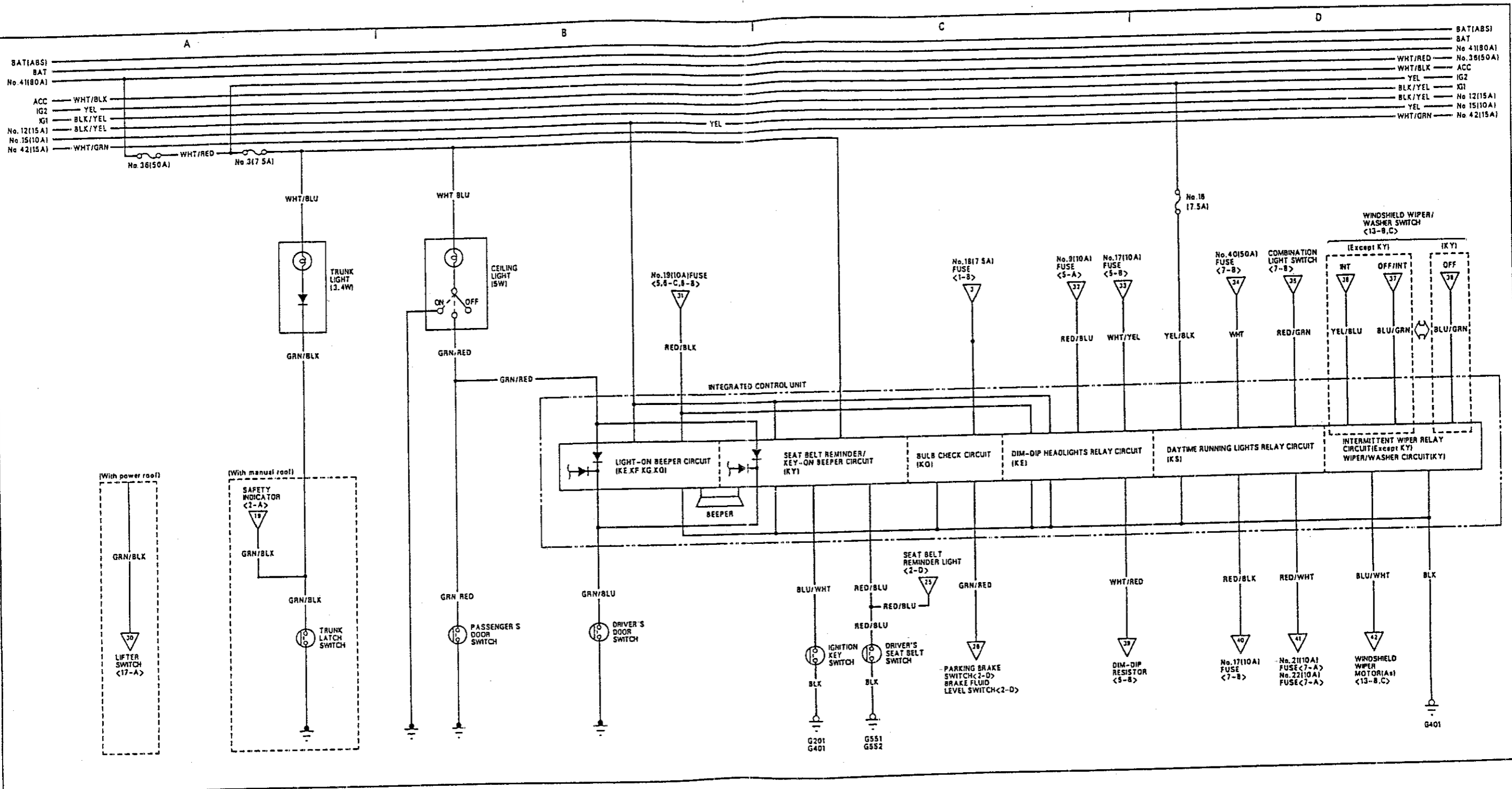

BAT(ABS)
 BAT
 No. 41(80A)
 ACC
 WHT/BLK
 IG2
 YEL
 No. 12(15A)
 XG1
 BLK/YEL
 No. 15(10A)
 BLK/YEL
 No. 42(15A)
 WHT/GRN

BAT(ABS)
 BAT
 No. 41(80A)
 No. 36(50A)
 ACC
 WHT/BLK
 YEL
 IG2
 BLK/YEL
 XG1
 BLK/YEL
 No. 12(15A)
 No. 15(10A)
 YEL
 No. 42(15A)
 WHT/GRN

[With power roof]
 GRN/BLK
 30
 LIFTER SWITCH <17-A>

[With manual roof]
 SAFETY INDICATOR <2-A>
 18
 GRN/BLK
 TRUNK LATCH SWITCH

GRN RED
 10
 10
 PASSENGER'S DOOR SWITCH

GRN/BLU
 10
 10
 DRIVER'S DOOR SWITCH

BLU/WHT
 10
 10
 IGNITION KEY SWITCH
 G201
 G401

RED/BLU
 RED/BLU
 10
 10
 DRIVER'S SEAT BELT SWITCH
 G551
 G552

GRN/RED
 25
 SEAT BELT REMINDER LIGHT <2-D>

WHT/RED
 39
 DIM-DIP RESISTOR <5-8>

RED/BLK
 40
 No. 17(10A) FUSE <7-8>

RED/WHT
 41
 No. 21(10A) FUSE <7-A>
 No. 22(10A) FUSE <7-A>

BLU/WHT
 42
 WINDSHIELD WIPER MOTOR(15-8,C)

G401

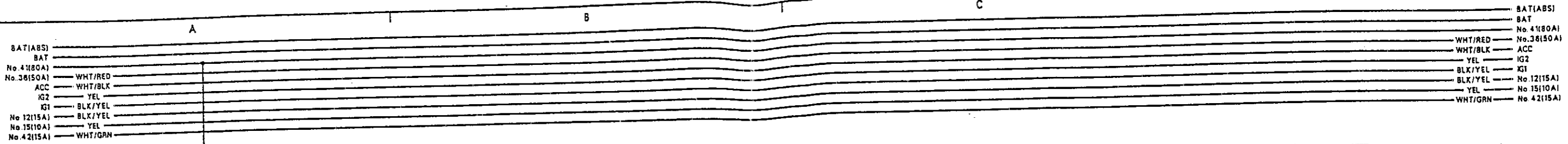

KE:

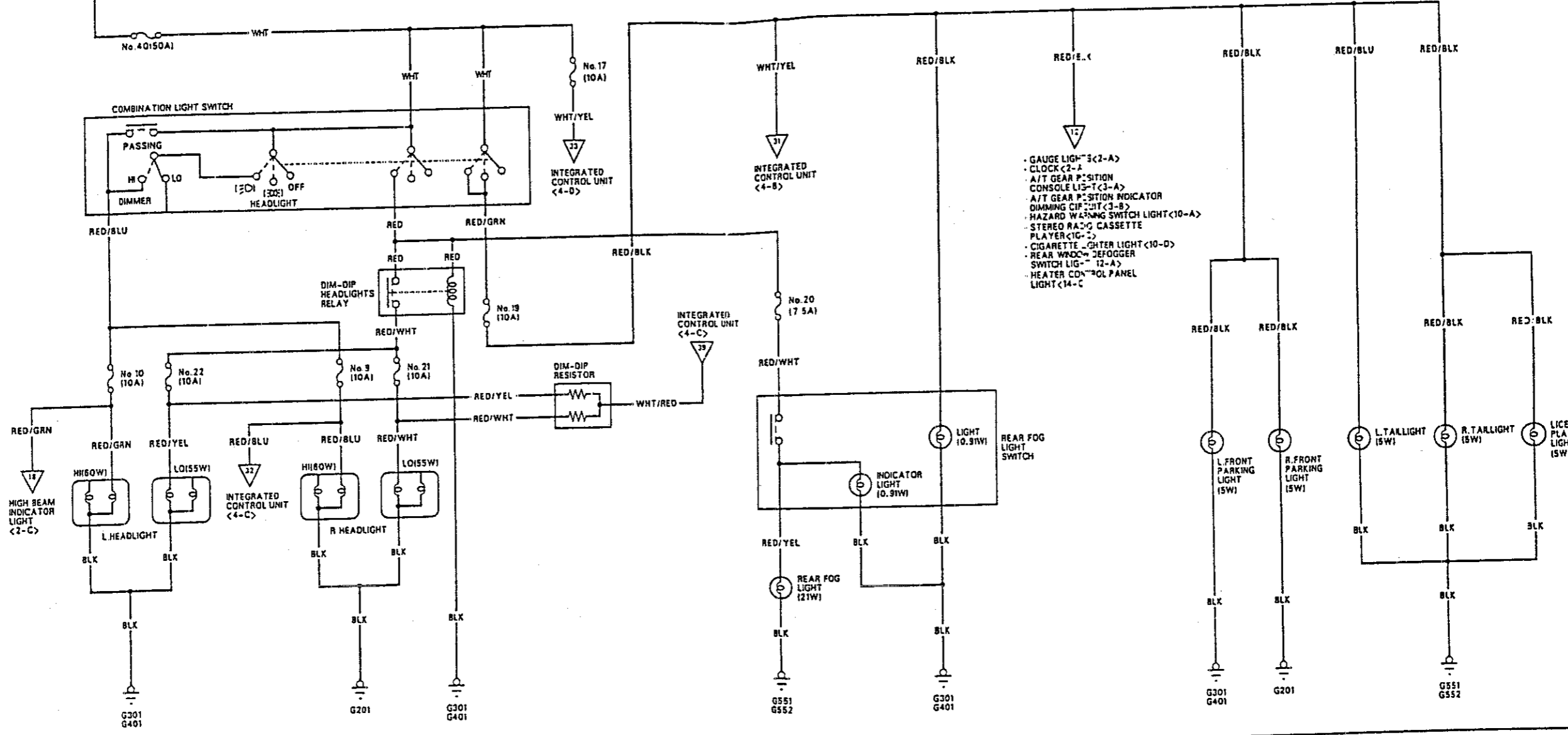

- GAUGE LIGHTS <2-A>
- CLOCK <2-A>
- A/T GEAR POSITION CONSOLE LIGHT <3-A>
- A/T GEAR POSITION INDICATOR DIMMING CIRCUIT <3-B>
- HAZARD WARNING SWITCH LIGHT <10-A>
- STEREO RADIO CASSETTE PLAYER <10-2>
- CIGARETTE LIGHTER LIGHT <10-D>
- REAR WINDOW DEFOGGER SWITCH LIGHT <12-A>
- HEATER CONTROL PANEL LIGHT <14-C>

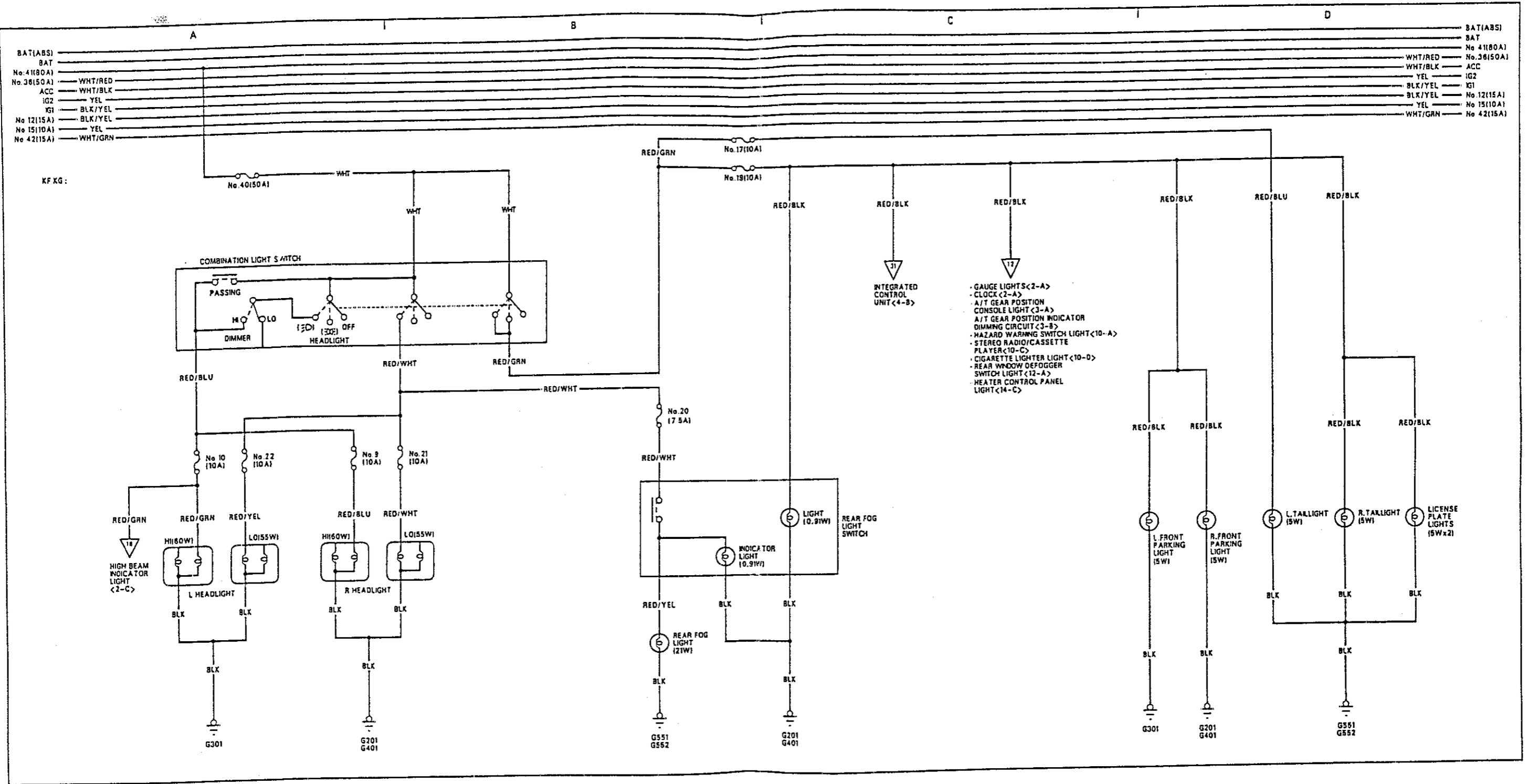

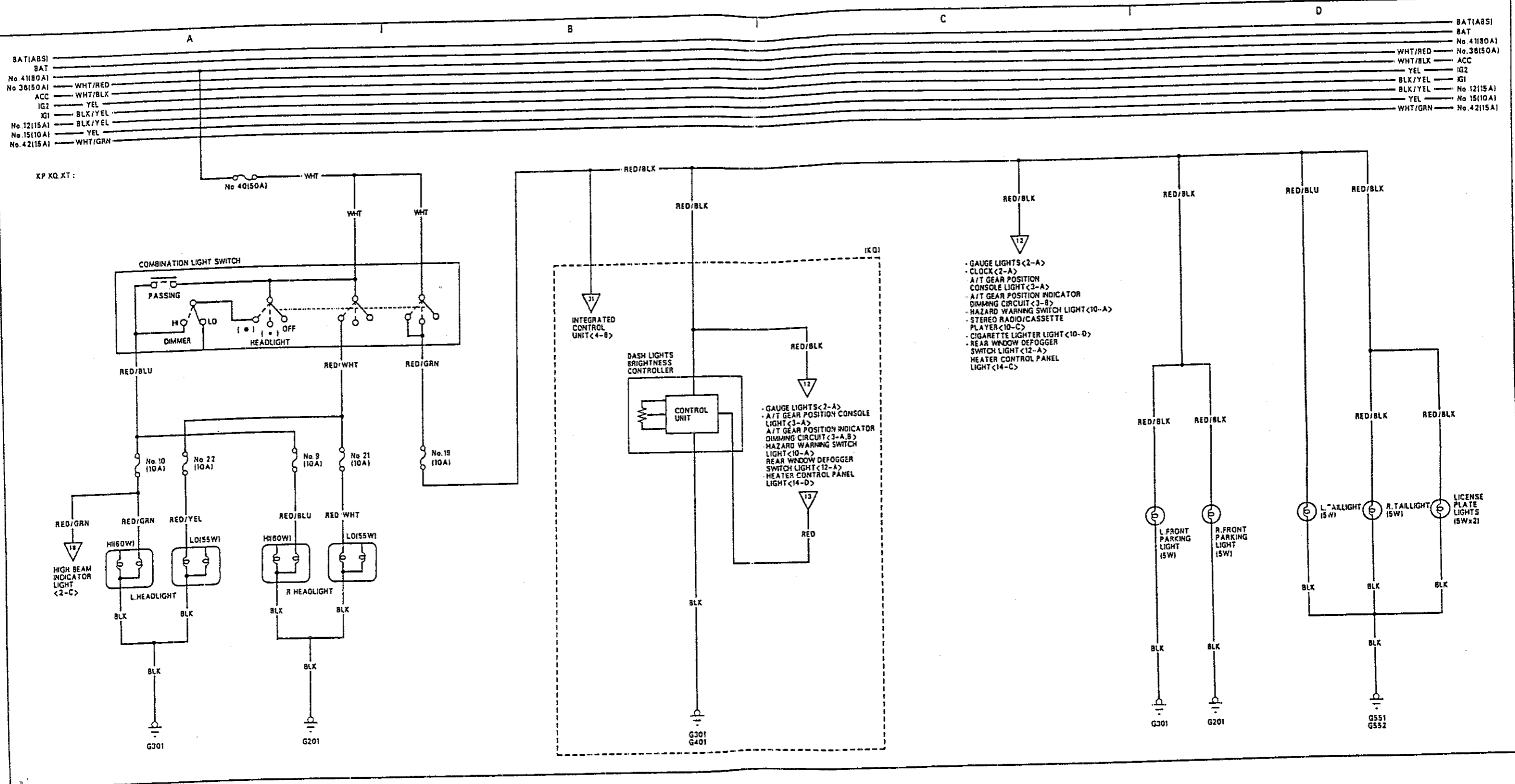

BAT(ABS)
 BAT
 No. 41(80A)
 No. 36(50A)
 ACC
 IG2
 IG1
 No. 12(15A)
 No. 15(10A)
 No. 42(15A)

BAT(ABS)
 BAT
 No. 41(80A)
 No. 36(50A)
 ACC
 IG2
 IG1
 No. 12(15A)
 No. 15(10A)
 No. 42(15A)

KP XQ XT :

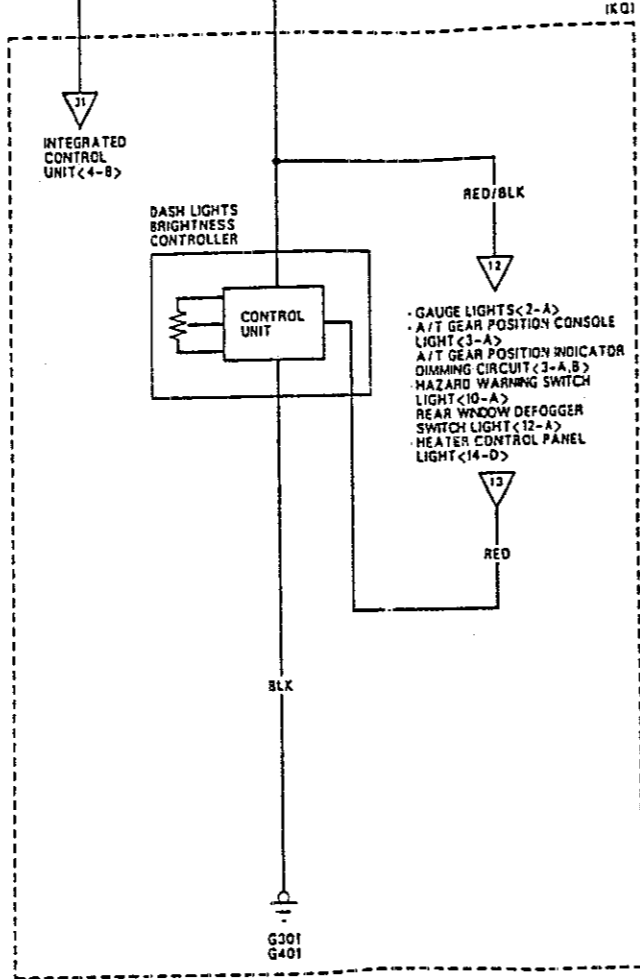
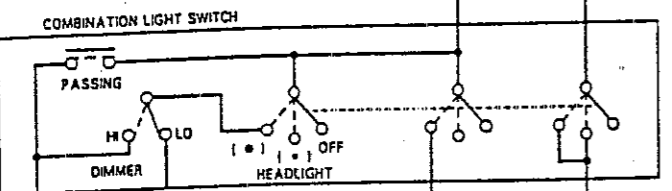

- GAUGE LIGHTS <2-A>
- CLOCK <2-A>
- A/T GEAR POSITION CONSOLE LIGHT <3-A>
- A/T GEAR POSITION INDICATOR DIMMING CIRCUIT <3-B>
- HAZARD WARNING SWITCH LIGHT <10-A>
- STEREO RADIO/CASSETTE PLAYER <10-C>
- CIGARETTE LIGHTER LIGHT <10-D>
- REAR WINDOW DEFOGGER SWITCH LIGHT <12-A>
- HEATER CONTROL PANEL LIGHT <14-C>

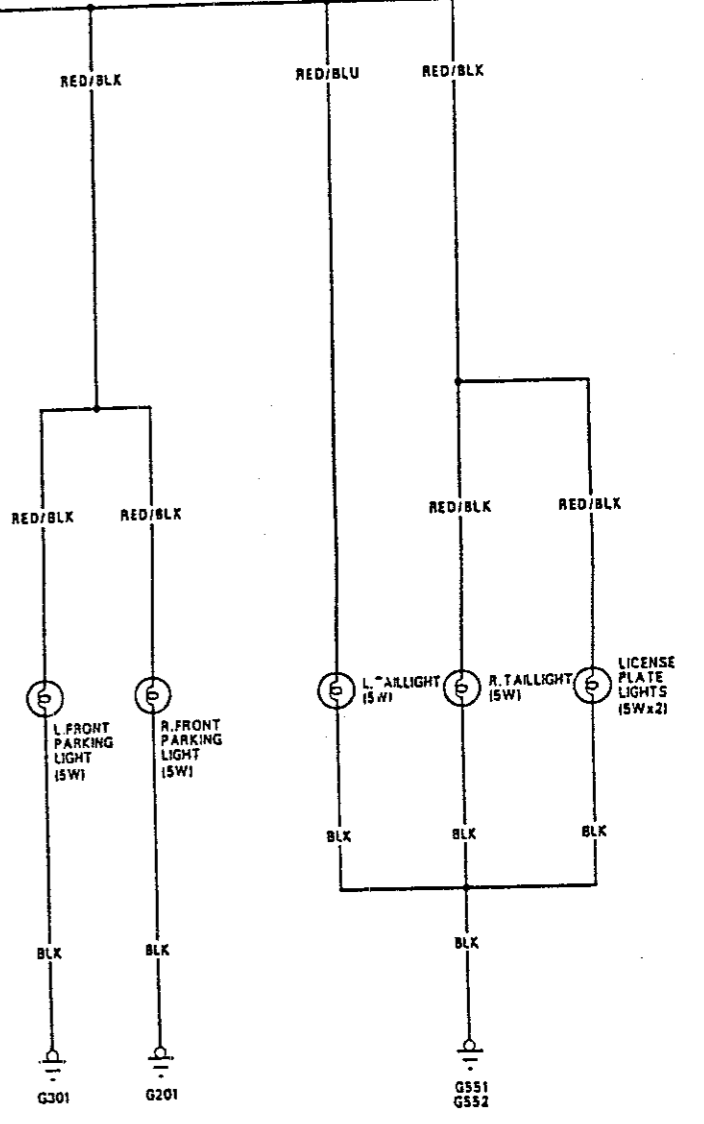

9

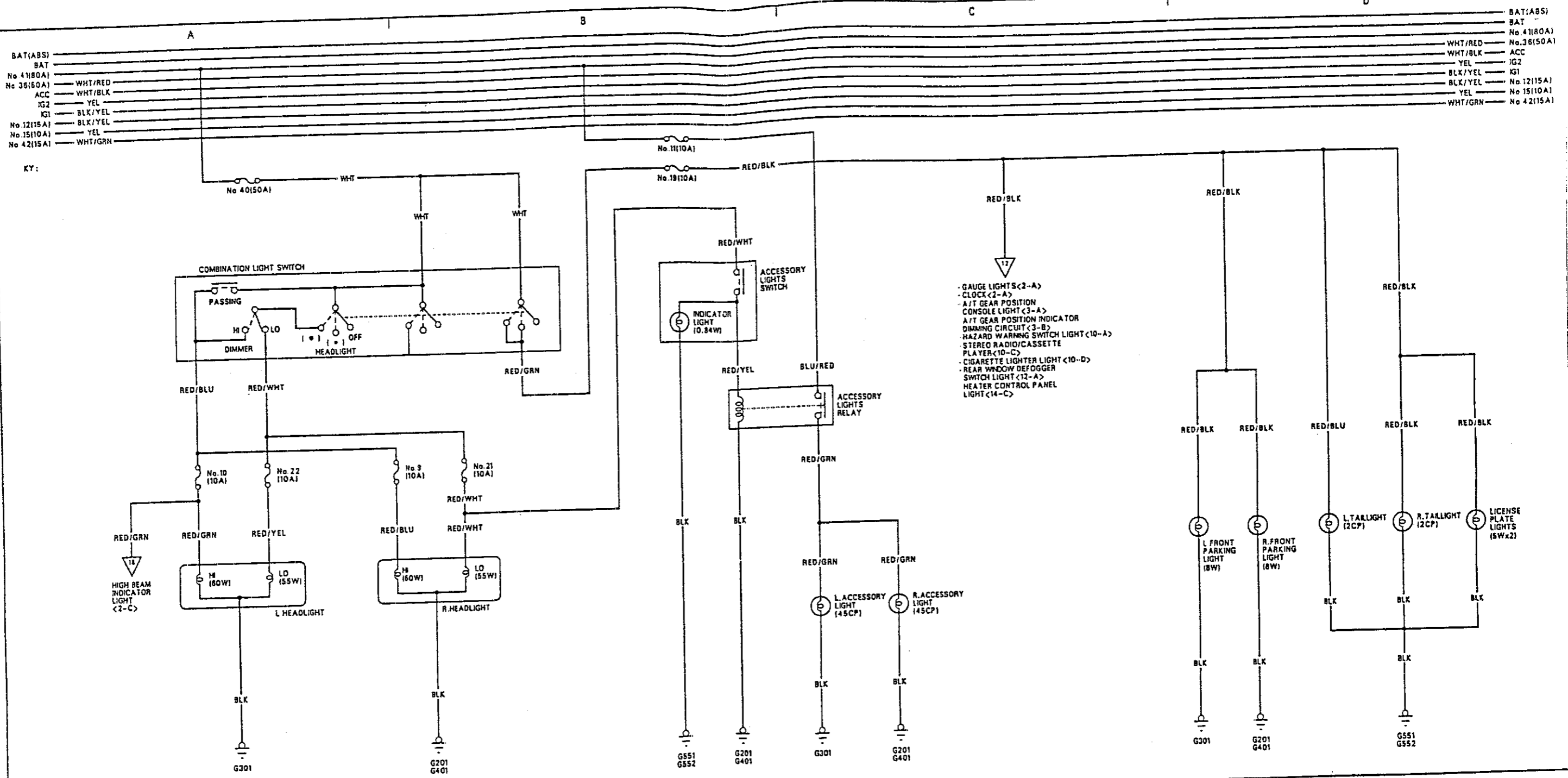

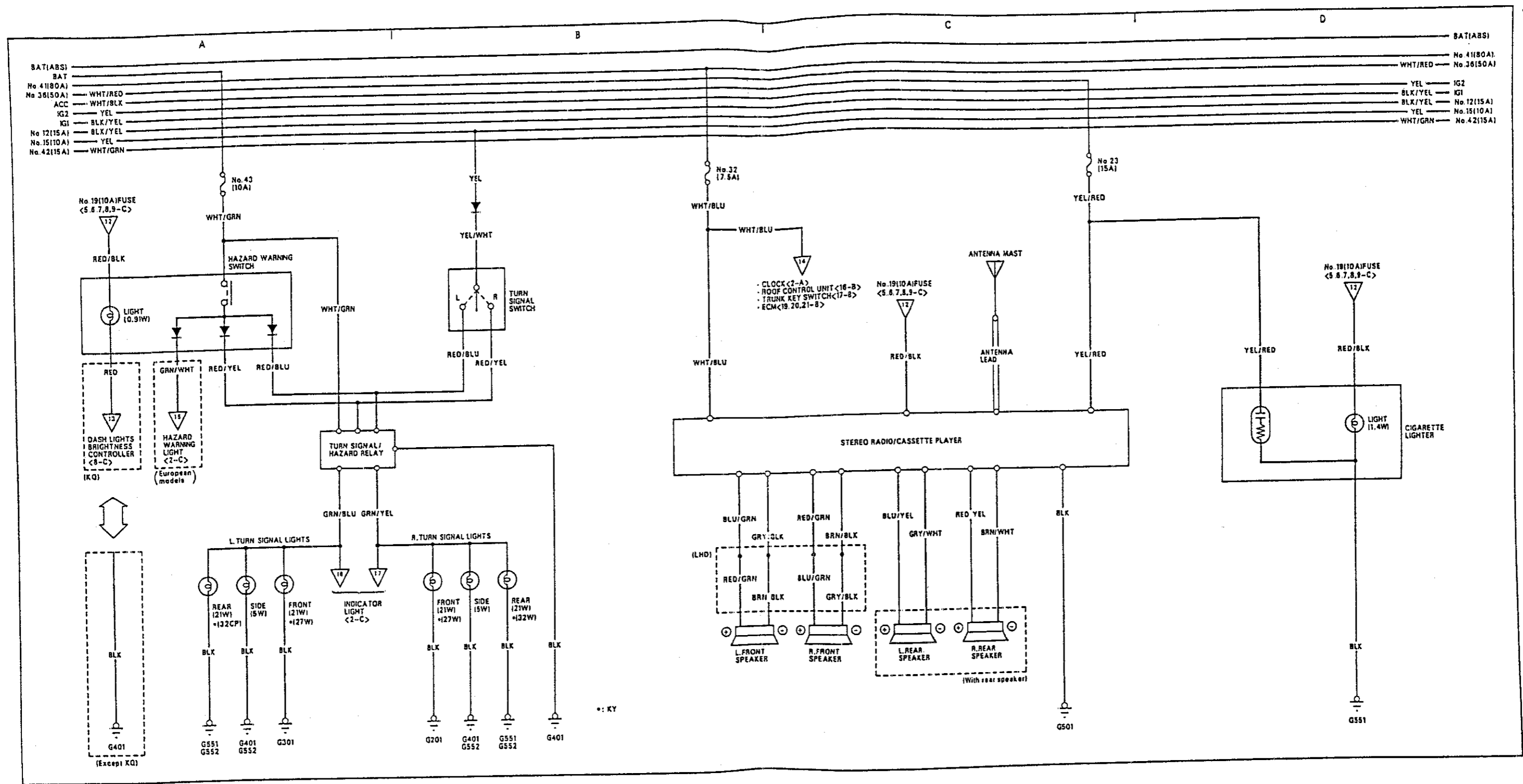

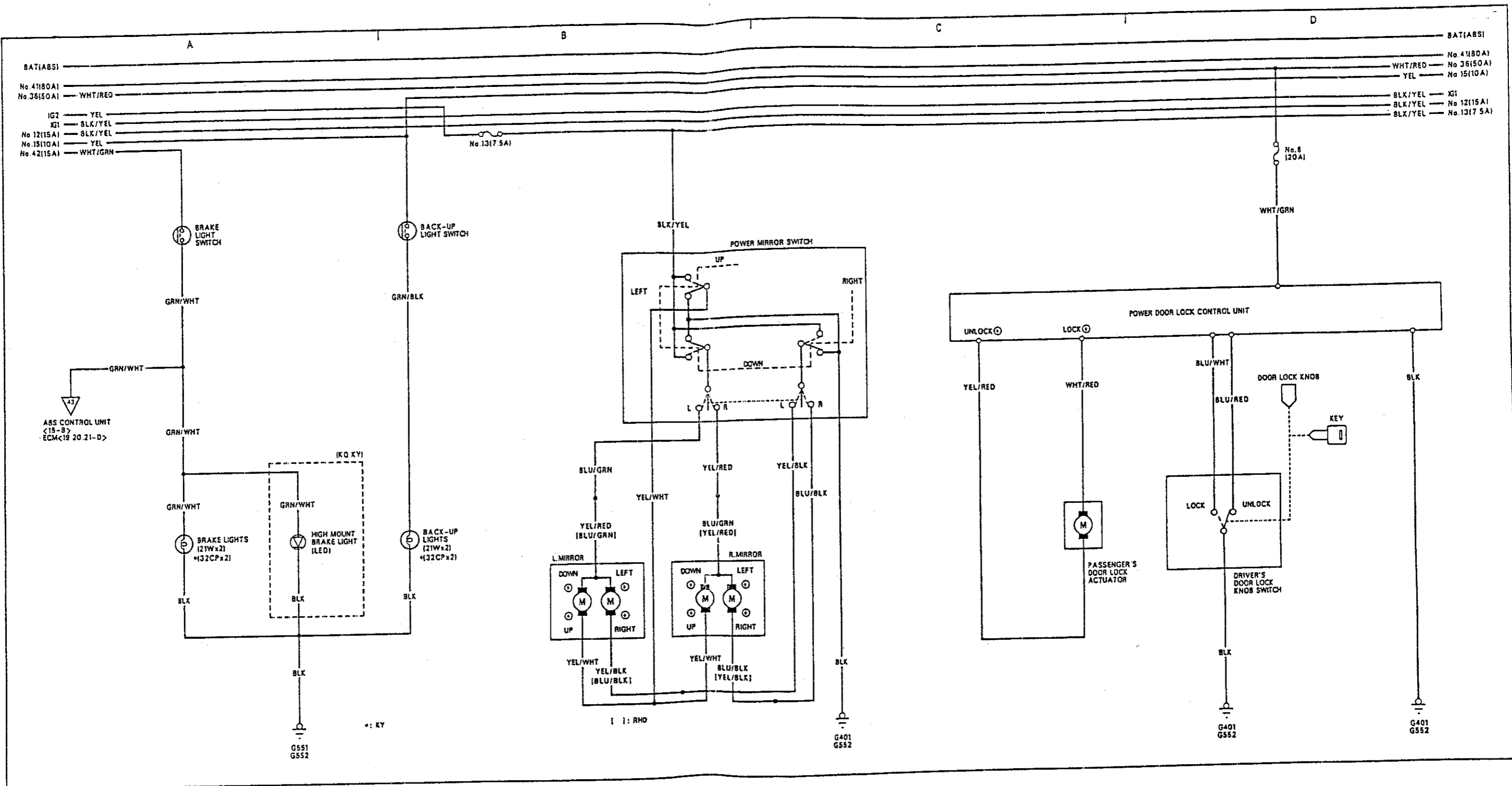

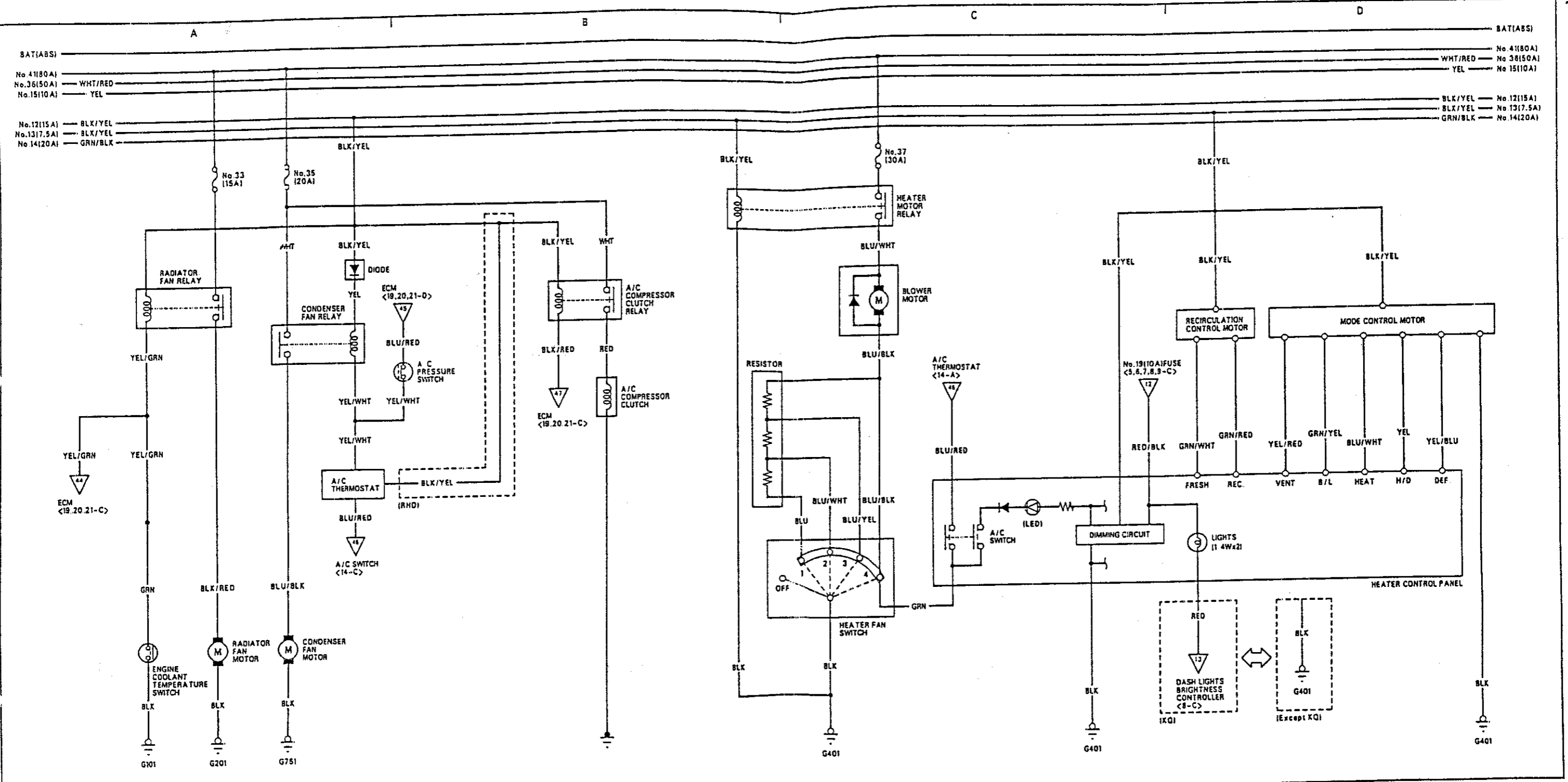

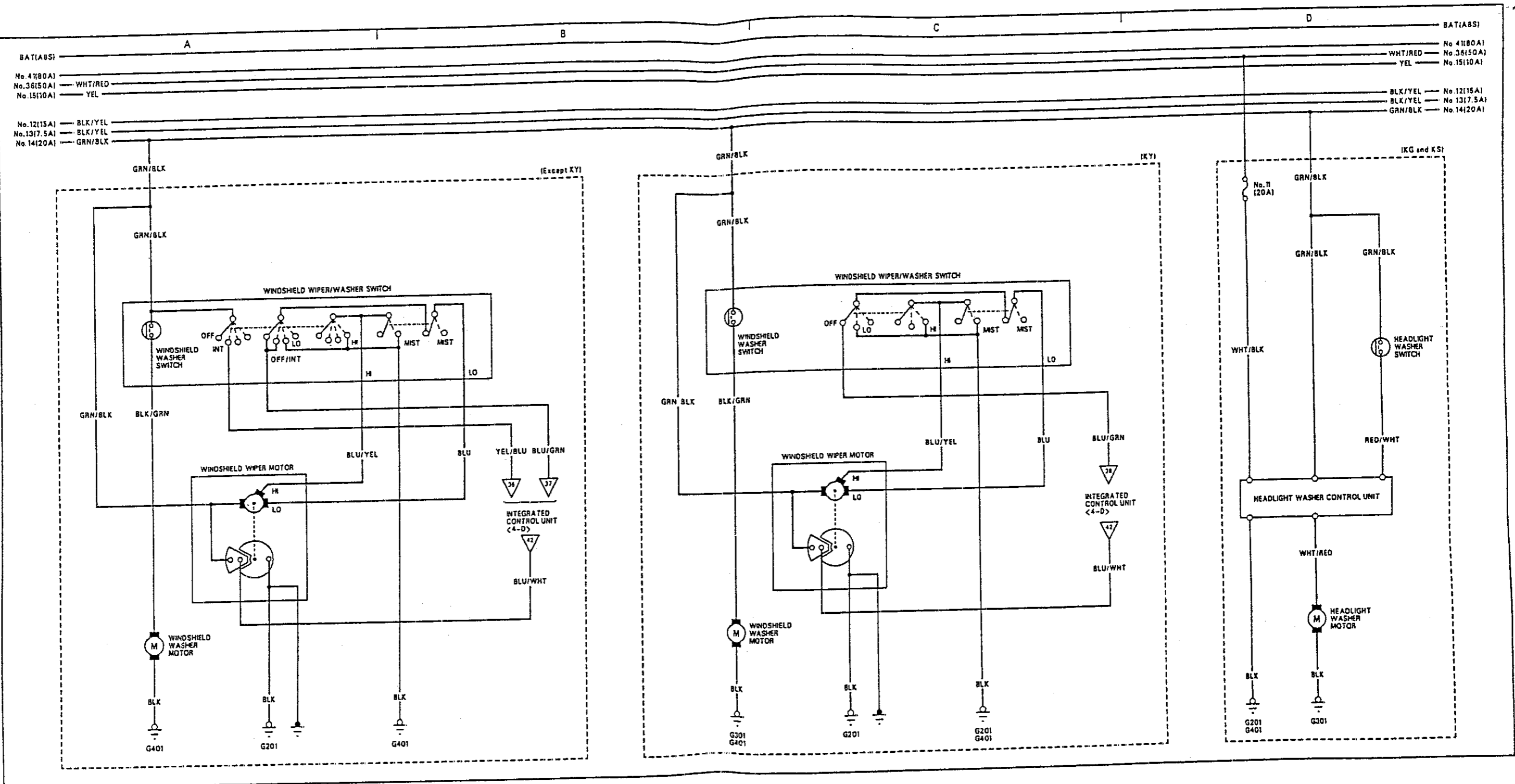

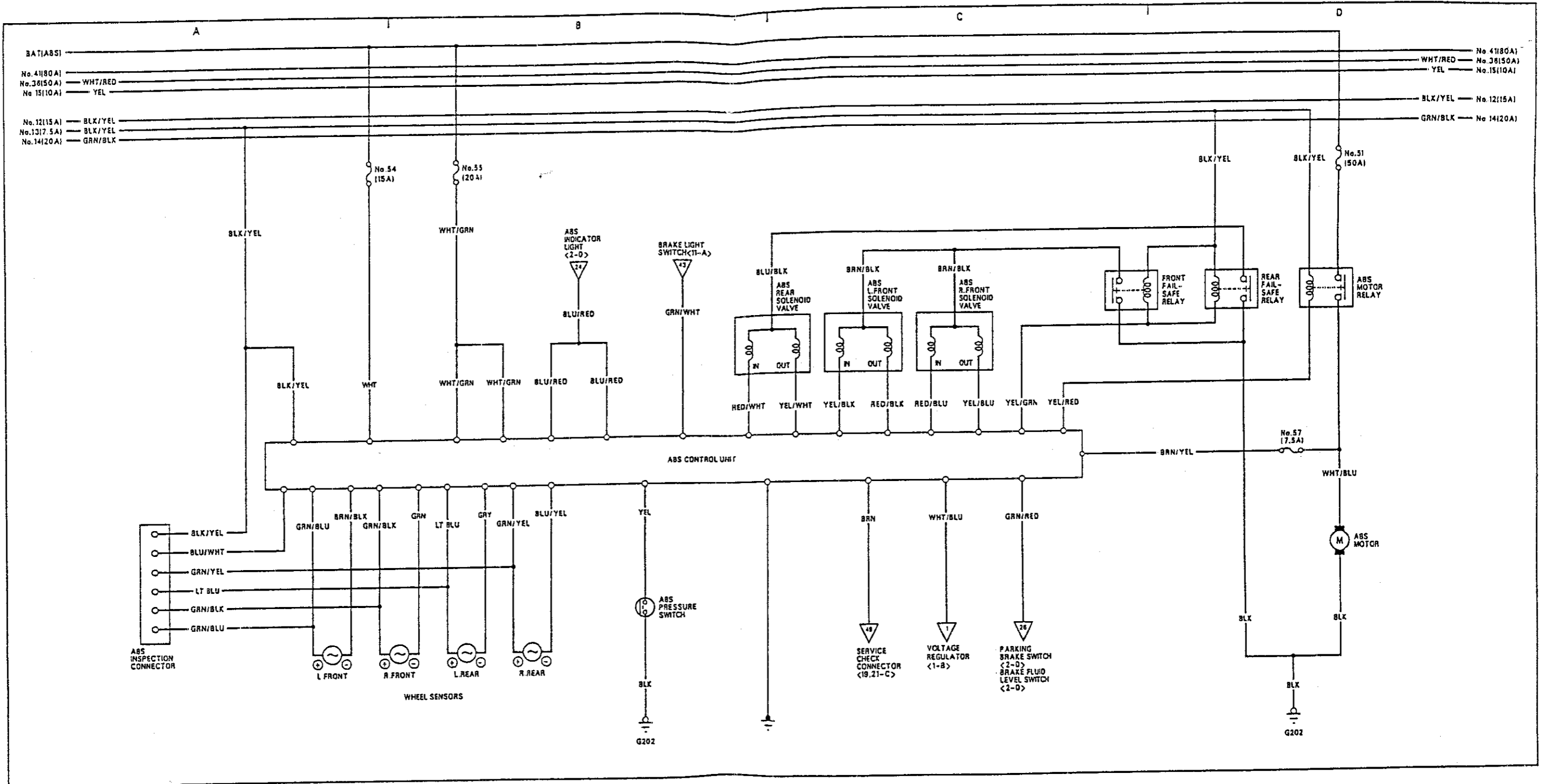

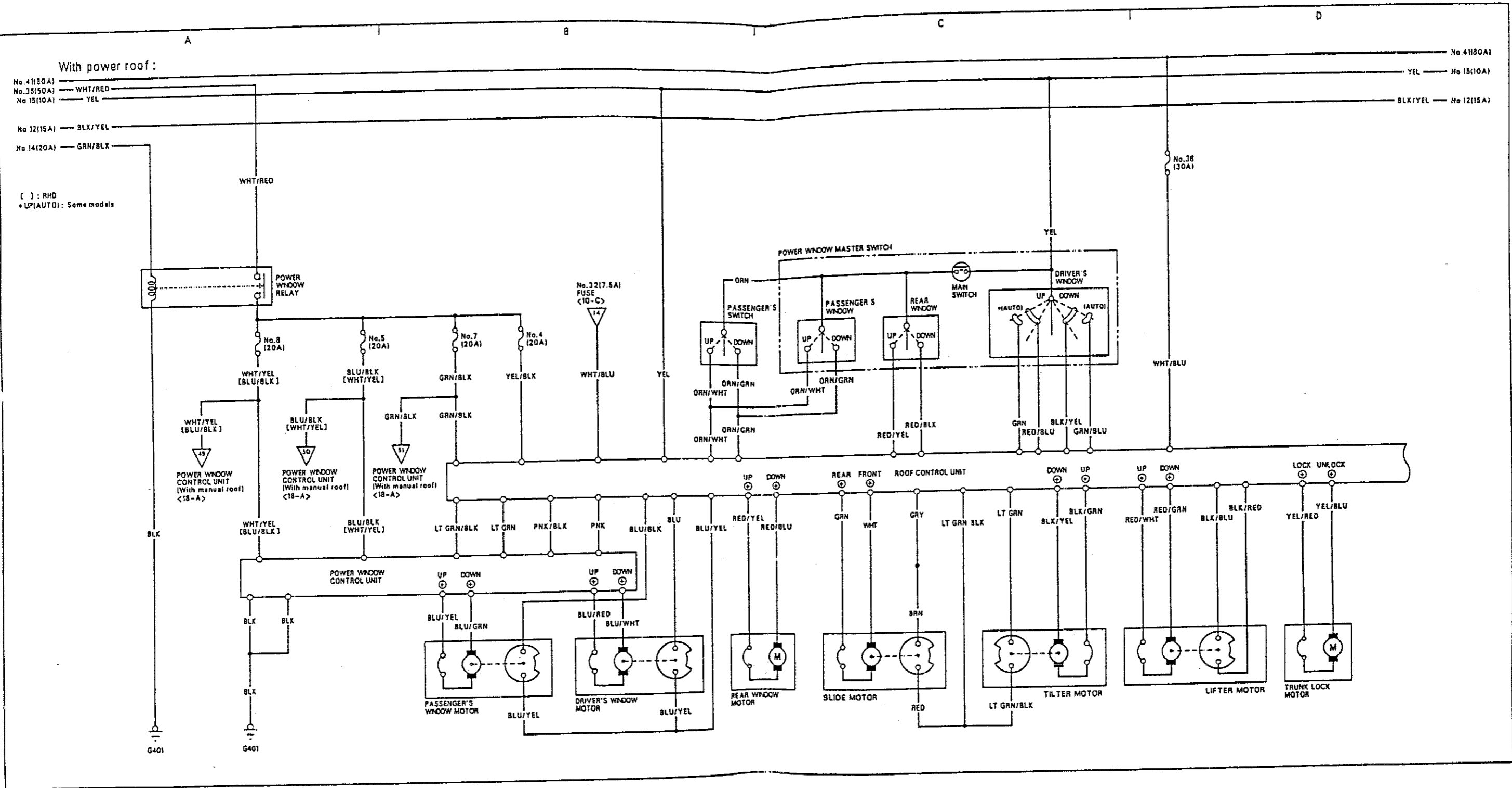

With power roof:

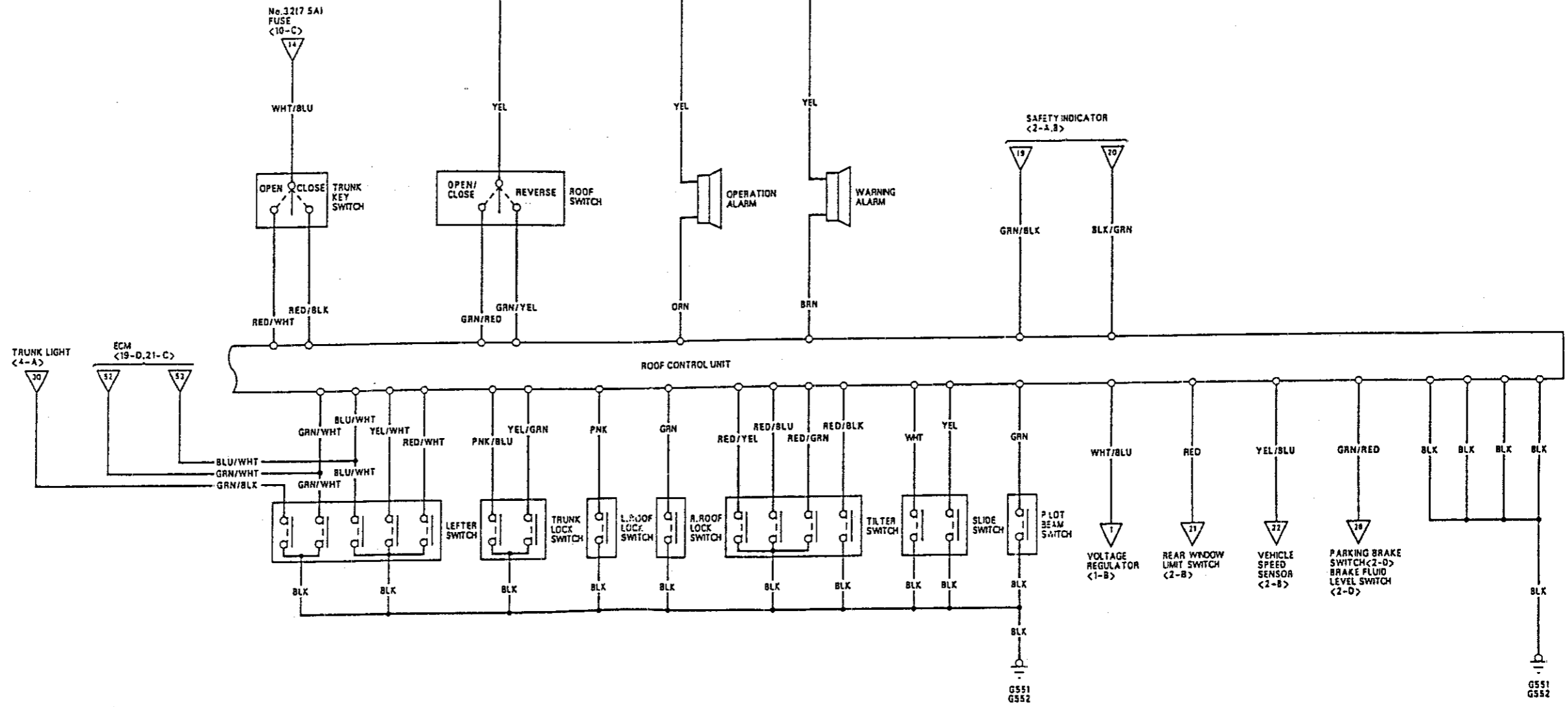
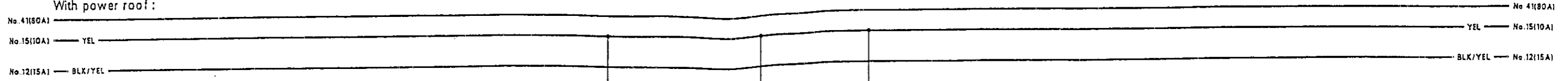

With manual roof:

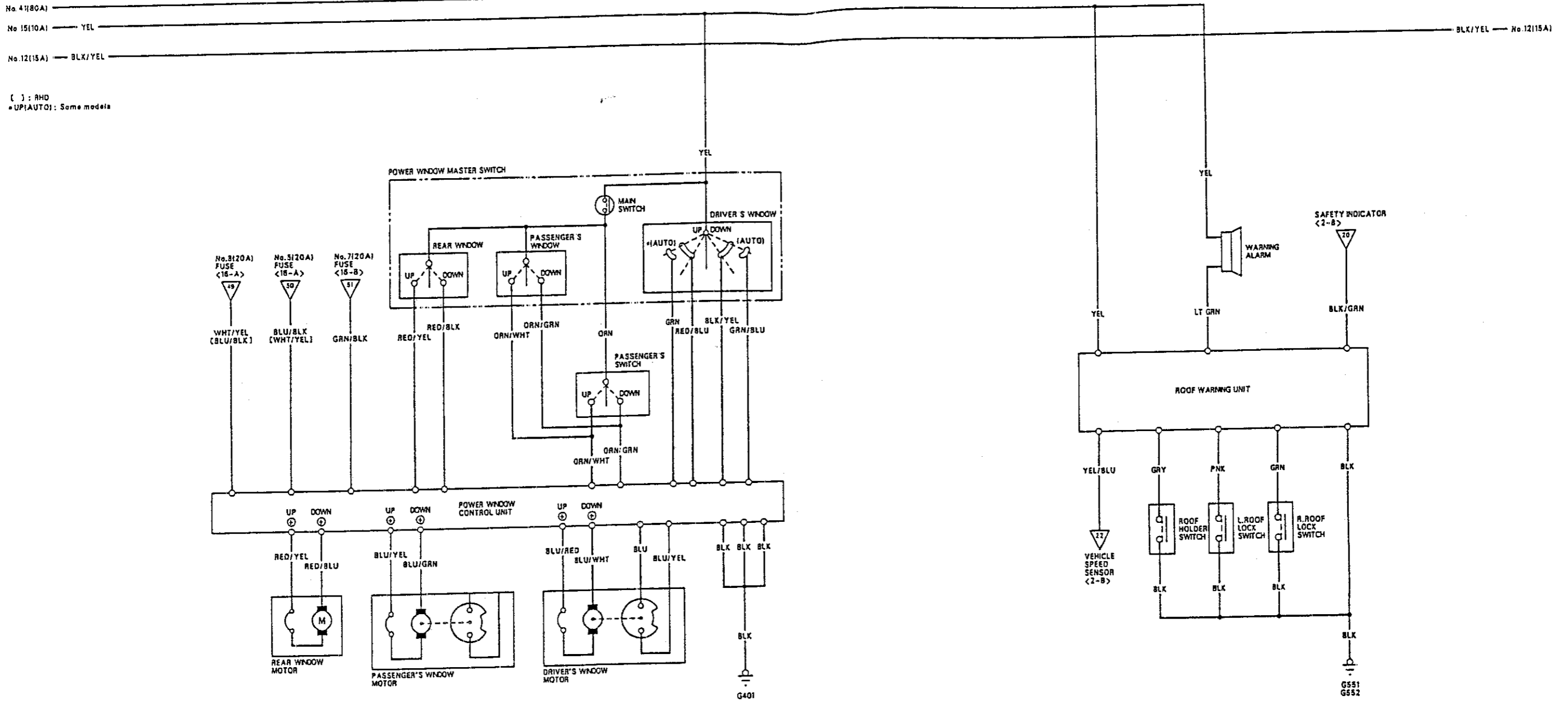

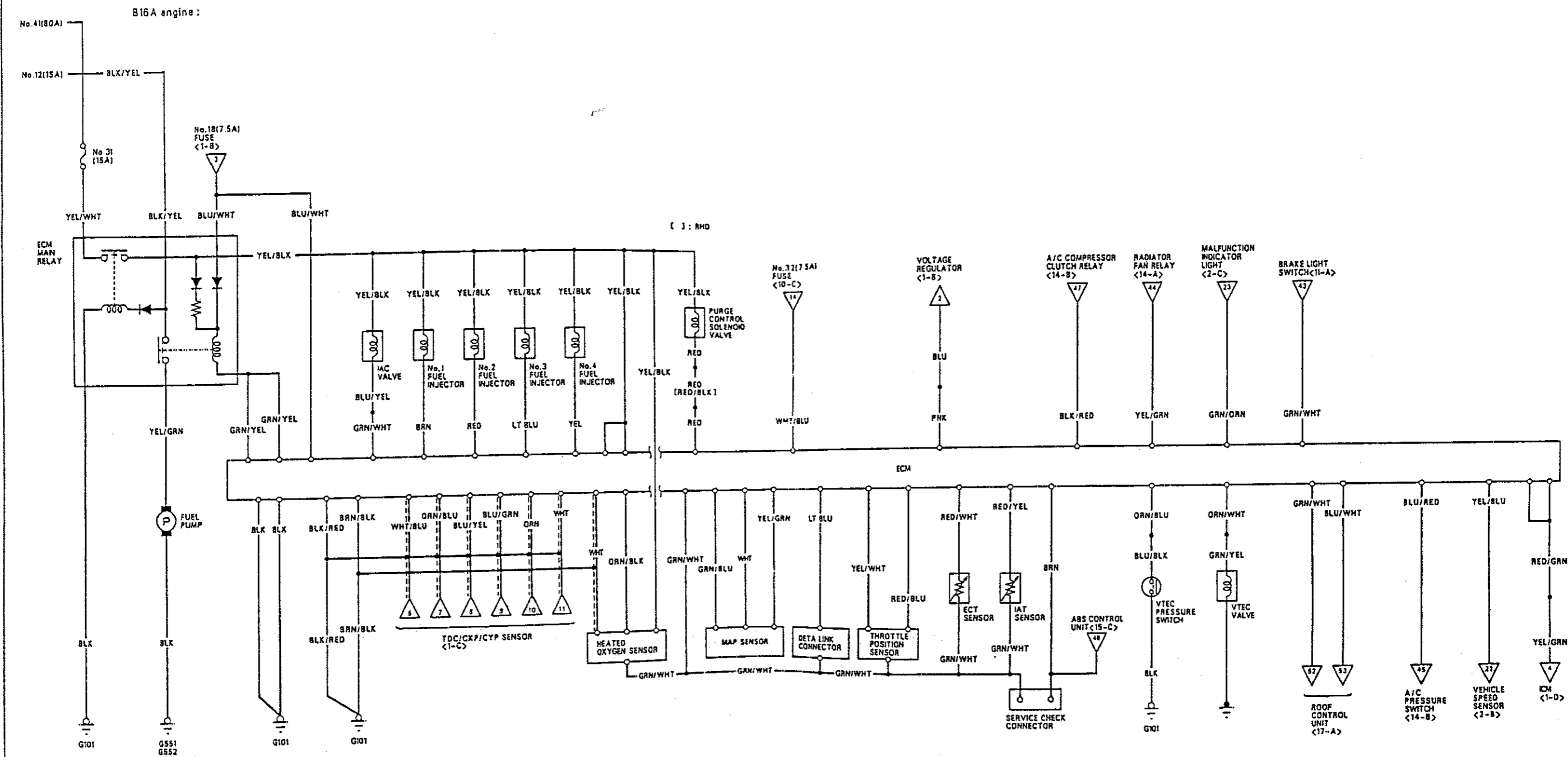

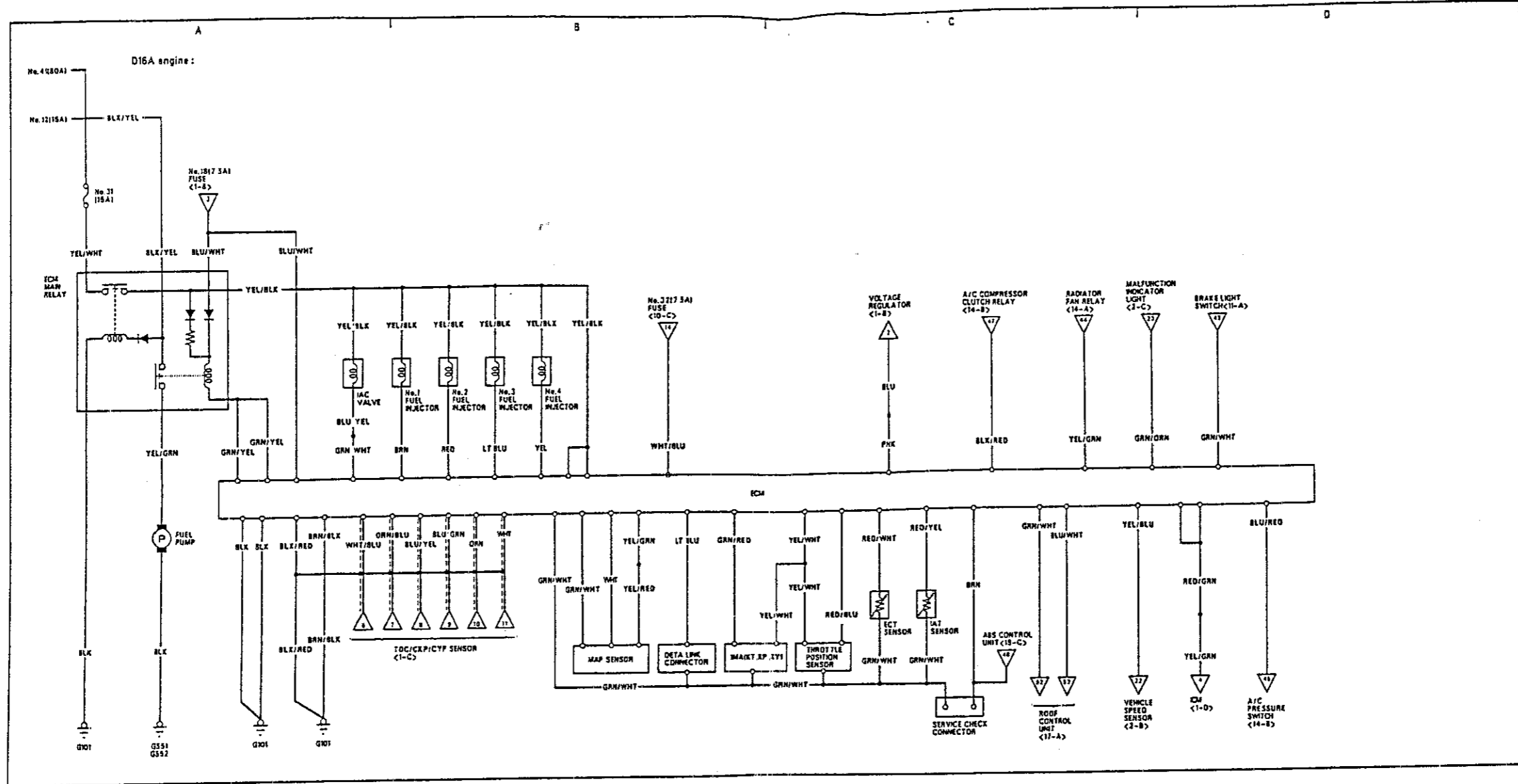

2 2 Fuel-Injected System Diagram [LHD]

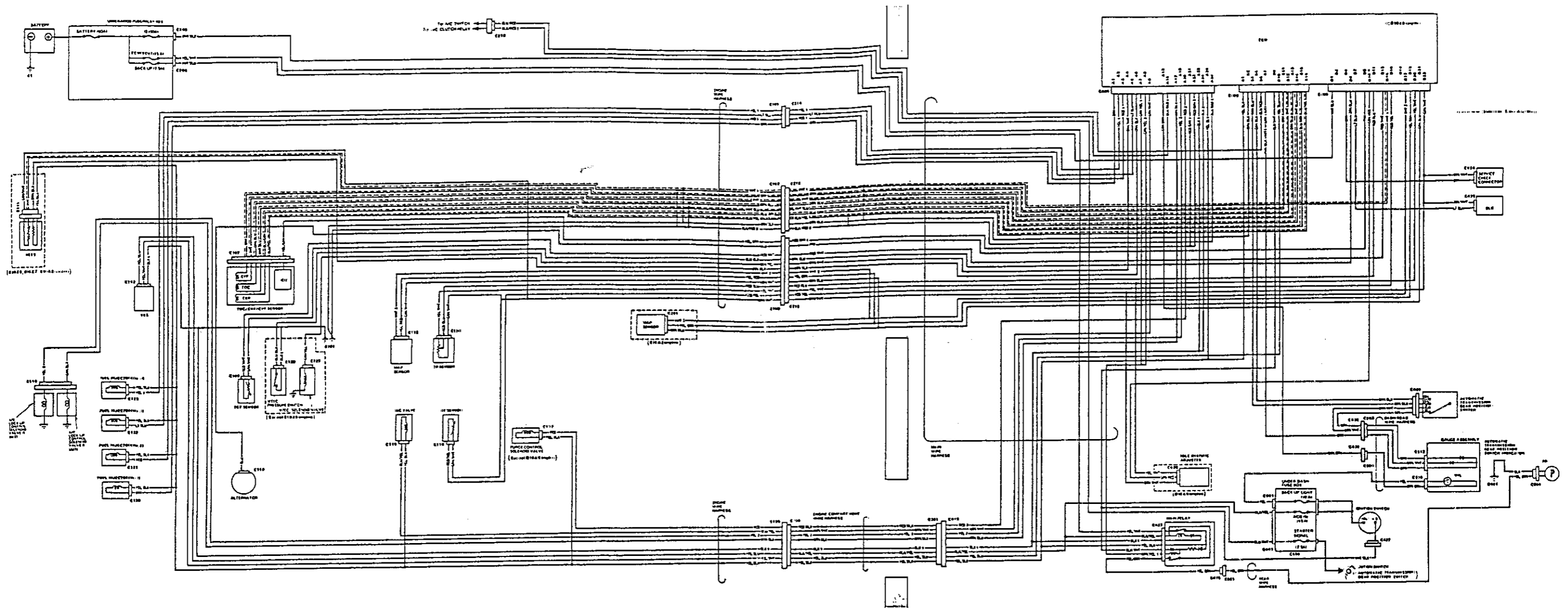

24 Fuel-Injected System Diagram [RHD]

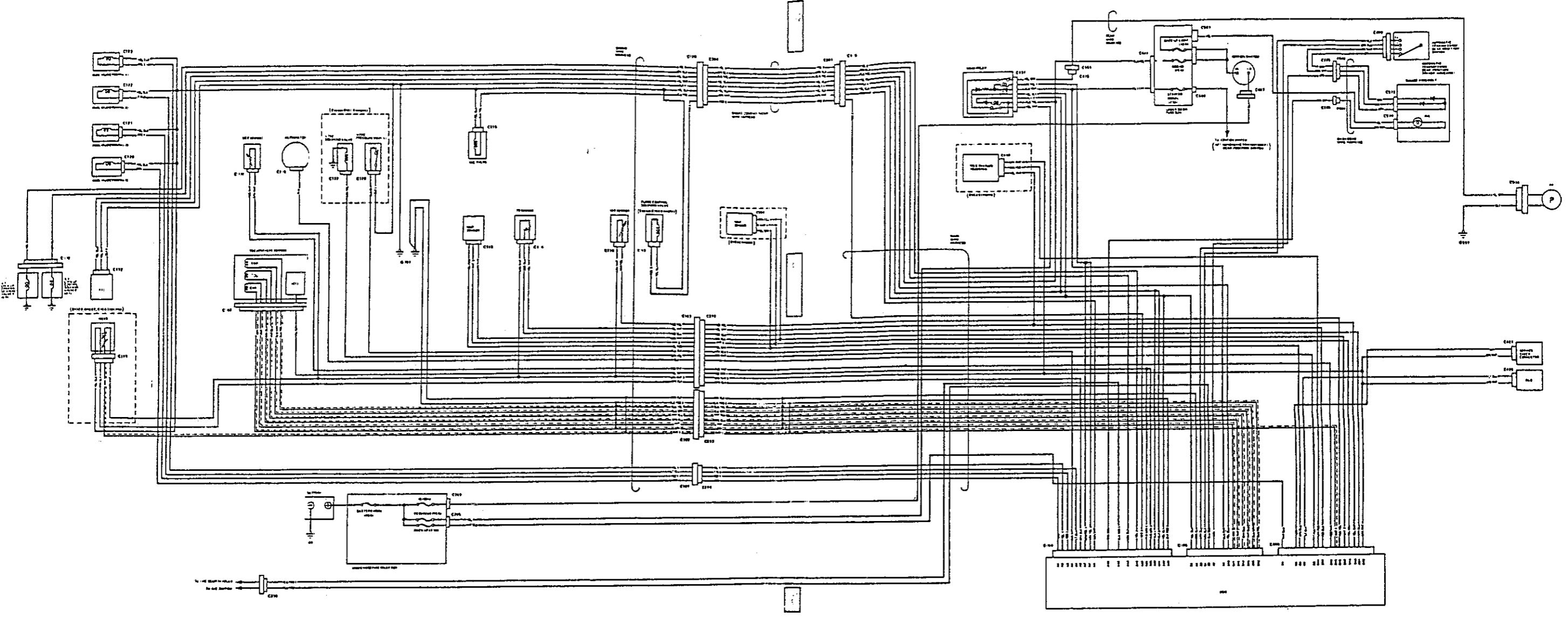

5 Fuel-Injected System Connectors [RHD]

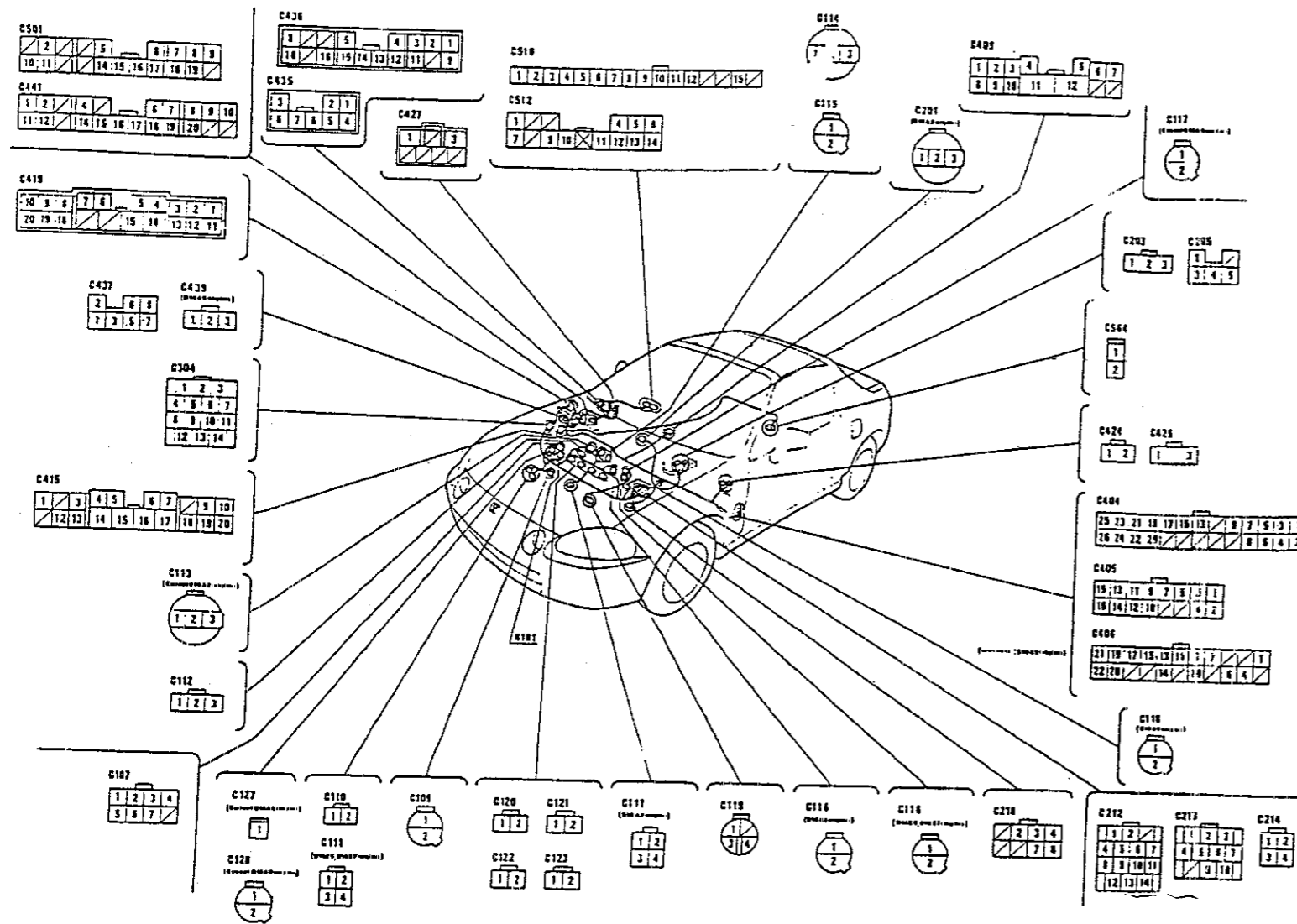

C101 1 GRN/BLU 2 GRN/WHY 3 YEL/BLK 4 WHY/BLU 5 WHY/BLU 6 WHY/BLU 7 WHY/BLU 8 WHY/BLU 9 WHY/BLU 10 WHY/BLU	C102 1 GRN/WHY 2 GRN/WHY 3 GRN/WHY 4 GRN/WHY 5 GRN/WHY 6 GRN/WHY 7 GRN/WHY 8 GRN/WHY 9 GRN/WHY 10 GRN/WHY	C103 1 GRN/WHY 2 GRN/WHY 3 GRN/WHY 4 GRN/WHY 5 GRN/WHY 6 GRN/WHY 7 GRN/WHY 8 GRN/WHY 9 GRN/WHY 10 GRN/WHY	C104 1 GRN/WHY 2 GRN/WHY 3 GRN/WHY 4 GRN/WHY 5 GRN/WHY 6 GRN/WHY 7 GRN/WHY 8 GRN/WHY 9 GRN/WHY 10 GRN/WHY	C105 1 GRN/WHY 2 GRN/WHY 3 GRN/WHY 4 GRN/WHY 5 GRN/WHY 6 GRN/WHY 7 GRN/WHY 8 GRN/WHY 9 GRN/WHY 10 GRN/WHY	C106 1 GRN/WHY 2 GRN/WHY 3 GRN/WHY 4 GRN/WHY 5 GRN/WHY 6 GRN/WHY 7 GRN/WHY 8 GRN/WHY 9 GRN/WHY 10 GRN/WHY	C107 1 GRN/WHY 2 GRN/WHY 3 GRN/WHY 4 GRN/WHY 5 GRN/WHY 6 GRN/WHY 7 GRN/WHY 8 GRN/WHY 9 GRN/WHY 10 GRN/WHY	C108 1 GRN/WHY 2 GRN/WHY 3 GRN/WHY 4 GRN/WHY 5 GRN/WHY 6 GRN/WHY 7 GRN/WHY 8 GRN/WHY 9 GRN/WHY 10 GRN/WHY	C109 1 GRN/WHY 2 GRN/WHY 3 GRN/WHY 4 GRN/WHY 5 GRN/WHY 6 GRN/WHY 7 GRN/WHY 8 GRN/WHY 9 GRN/WHY 10 GRN/WHY	C110 1 GRN/WHY 2 GRN/WHY 3 GRN/WHY 4 GRN/WHY 5 GRN/WHY 6 GRN/WHY 7 GRN/WHY 8 GRN/WHY 9 GRN/WHY 10 GRN/WHY	C111 1 GRN/WHY 2 GRN/WHY 3 GRN/WHY 4 GRN/WHY 5 GRN/WHY 6 GRN/WHY 7 GRN/WHY 8 GRN/WHY 9 GRN/WHY 10 GRN/WHY	C112 1 GRN/WHY 2 GRN/WHY 3 GRN/WHY 4 GRN/WHY 5 GRN/WHY 6 GRN/WHY 7 GRN/WHY 8 GRN/WHY 9 GRN/WHY 10 GRN/WHY	C113 1 GRN/WHY 2 GRN/WHY 3 GRN/WHY 4 GRN/WHY 5 GRN/WHY 6 GRN/WHY 7 GRN/WHY 8 GRN/WHY 9 GRN/WHY 10 GRN/WHY	C114 1 GRN/WHY 2 GRN/WHY 3 GRN/WHY 4 GRN/WHY 5 GRN/WHY 6 GRN/WHY 7 GRN/WHY 8 GRN/WHY 9 GRN/WHY 10 GRN/WHY	C115 1 GRN/WHY 2 GRN/WHY 3 GRN/WHY 4 GRN/WHY 5 GRN/WHY 6 GRN/WHY 7 GRN/WHY 8 GRN/WHY 9 GRN/WHY 10 GRN/WHY	C116 1 GRN 2 YEL	C117 1 GRN 2 YEL	C118 1 GRN 2 YEL	C119 1 GRN 2 YEL	C120 1 GRN 2 YEL	C121 1 GRN 2 YEL	C122 1 GRN 2 YEL	C123 1 GRN 2 YEL	C124 1 GRN 2 YEL	C125 1 GRN 2 YEL	C126 1 GRN 2 YEL	C127 1 GRN 2 YEL	C128 1 GRN 2 YEL	C129 1 GRN 2 YEL	C130 1 GRN 2 YEL	C131 1 GRN 2 YEL	C132 1 GRN 2 YEL	C133 1 GRN 2 YEL	C134 1 GRN 2 YEL	C135 1 GRN 2 YEL	C136 1 GRN 2 YEL	C137 1 GRN 2 YEL	C138 1 GRN 2 YEL	C139 1 GRN 2 YEL	C140 1 GRN 2 YEL	C141 1 GRN 2 YEL	C142 1 GRN 2 YEL	C143 1 GRN 2 YEL	C144 1 GRN 2 YEL	C145 1 GRN 2 YEL	C146 1 GRN 2 YEL	C147 1 GRN 2 YEL	C148 1 GRN 2 YEL	C149 1 GRN 2 YEL	C150 1 GRN 2 YEL	C151 1 GRN 2 YEL	C152 1 GRN 2 YEL	C153 1 GRN 2 YEL	C154 1 GRN 2 YEL	C155 1 GRN 2 YEL	C156 1 GRN 2 YEL	C157 1 GRN 2 YEL	C158 1 GRN 2 YEL	C159 1 GRN 2 YEL	C160 1 GRN 2 YEL	C161 1 GRN 2 YEL	C162 1 GRN 2 YEL	C163 1 GRN 2 YEL	C164 1 GRN 2 YEL	C165 1 GRN 2 YEL	C166 1 GRN 2 YEL	C167 1 GRN 2 YEL	C168 1 GRN 2 YEL	C169 1 GRN 2 YEL	C170 1 GRN 2 YEL	C171 1 GRN 2 YEL	C172 1 GRN 2 YEL	C173 1 GRN 2 YEL	C174 1 GRN 2 YEL	C175 1 GRN 2 YEL	C176 1 GRN 2 YEL	C177 1 GRN 2 YEL	C178 1 GRN 2 YEL	C179 1 GRN 2 YEL	C180 1 GRN 2 YEL	C181 1 GRN 2 YEL	C182 1 GRN 2 YEL	C183 1 GRN 2 YEL	C184 1 GRN 2 YEL	C185 1 GRN 2 YEL	C186 1 GRN 2 YEL	C187 1 GRN 2 YEL	C188 1 GRN 2 YEL	C189 1 GRN 2 YEL	C190 1 GRN 2 YEL	C191 1 GRN 2 YEL	C192 1 GRN 2 YEL	C193 1 GRN 2 YEL	C194 1 GRN 2 YEL	C195 1 GRN 2 YEL	C196 1 GRN 2 YEL	C197 1 GRN 2 YEL	C198 1 GRN 2 YEL	C199 1 GRN 2 YEL	C200 1 GRN 2 YEL	C201 1 GRN 2 YEL	C202 1 GRN 2 YEL	C203 1 GRN 2 YEL	C204 1 GRN 2 YEL	C205 1 GRN 2 YEL	C206 1 GRN 2 YEL	C207 1 GRN 2 YEL	C208 1 GRN 2 YEL	C209 1 GRN 2 YEL	C210 1 GRN 2 YEL	C211 1 GRN 2 YEL	C212 1 GRN 2 YEL	C213 1 GRN 2 YEL	C214 1 GRN 2 YEL	C215 1 GRN 2 YEL	C216 1 GRN 2 YEL	C217 1 GRN 2 YEL	C218 1 GRN 2 YEL
--	--	--	--	--	--	--	--	--	--	--	--	--	--	--	-------------------------------	-------------------------------	-------------------------------	-------------------------------	-------------------------------	-------------------------------	-------------------------------	-------------------------------	-------------------------------	-------------------------------	-------------------------------	-------------------------------	-------------------------------	-------------------------------	-------------------------------	-------------------------------	-------------------------------	-------------------------------	-------------------------------	-------------------------------	-------------------------------	-------------------------------	-------------------------------	-------------------------------	-------------------------------	-------------------------------	-------------------------------	-------------------------------	-------------------------------	-------------------------------	-------------------------------	-------------------------------	-------------------------------	-------------------------------	-------------------------------	-------------------------------	-------------------------------	-------------------------------	-------------------------------	-------------------------------	-------------------------------	-------------------------------	-------------------------------	-------------------------------	-------------------------------	-------------------------------	-------------------------------	-------------------------------	-------------------------------	-------------------------------	-------------------------------	-------------------------------	-------------------------------	-------------------------------	-------------------------------	-------------------------------	-------------------------------	-------------------------------	-------------------------------	-------------------------------	-------------------------------	-------------------------------	-------------------------------	-------------------------------	-------------------------------	-------------------------------	-------------------------------	-------------------------------	-------------------------------	-------------------------------	-------------------------------	-------------------------------	-------------------------------	-------------------------------	-------------------------------	-------------------------------	-------------------------------	-------------------------------	-------------------------------	-------------------------------	-------------------------------	-------------------------------	-------------------------------	-------------------------------	-------------------------------	-------------------------------	-------------------------------	-------------------------------	-------------------------------	-------------------------------	-------------------------------	-------------------------------	-------------------------------	-------------------------------	-------------------------------	-------------------------------	-------------------------------	-------------------------------	-------------------------------	-------------------------------	-------------------------------	-------------------------------	-------------------------------

NOTE: Several different wires have the same color. They have been given a number suffix to distinguish them (for example YEL/BLK¹ and YEL/BLK² are not the same).
O: Related to PGM-FI SYSTEM

*1: with power roof
*2: Except B16A2 engine
*3: A/T
*4: Except D16A9 engine
*5: D16A9 engine
*6: KE
*7: with manual roof
*8: with ABS