

## Clutch

Special Tools .....	12-2
Illustrated Index .....	12-3
Pedal Free Play	
Adjustment .....	12-4
Clutch Master Cylinder	
Overhaul/Inspection .....	12-5
Removal/Installation .....	12-6
Disassembly .....	12-7
Reassembly .....	12-7
Slave Cylinder	
Overhaul/Inspection .....	12-8
Removal .....	12-9
Installation .....	12-9
Pressure Plate	
Removal/Inspection .....	12-10
Clutch Disc	
Removal/Inspection .....	12-11
Flywheel	
Inspection .....	12-12
Replacement .....	12-12
Release Bearing	
Removal/Inspection .....	12-13
Installation .....	12-14
Clutch Disc, Pressure Plate	
Installation .....	12-14



# Special Tools

## Special Tools

Ref. No.	Tool Number	Description	Qty	Remarks
①	07JAF-PM7012A	Clutch Alignment Shaft	1	Except B16A2 07924-PD20003 B16A2
②	07LAB-PV00100	Ring Gear Holder	1	
③	07LAF-PR30200	Clutch Alignment Tool	1	
③-1	07JAF-PM7011A	Clutch Alignment Disc	(1)	Component Tools
③-2	07LAF-PR30210	Clutch Alignment Shaft	(1)	
③-3	07936-3710100	Handle	(1)	
④	07746-0010100	Outer Driver, 32 x 35 mm	1	
⑤	07749-0010000	Outer Handle A	1	

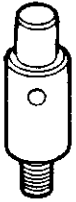

①

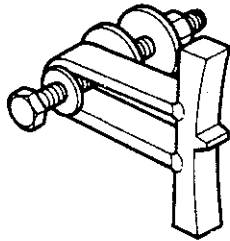

②

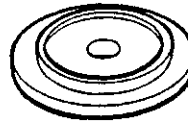

③-1



③-2

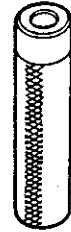

③-3

③

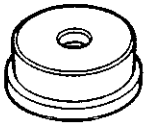

④

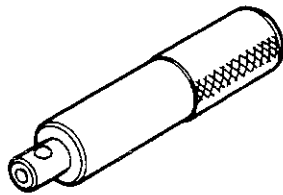

⑤



# Illustrated Index

## NOTE:

- Whenever the transmission is removed, clean and grease the release bearing sliding surface
- If the parts marked \* are removed, the clutch hydraulic system must be bled
- LHD type is shown.

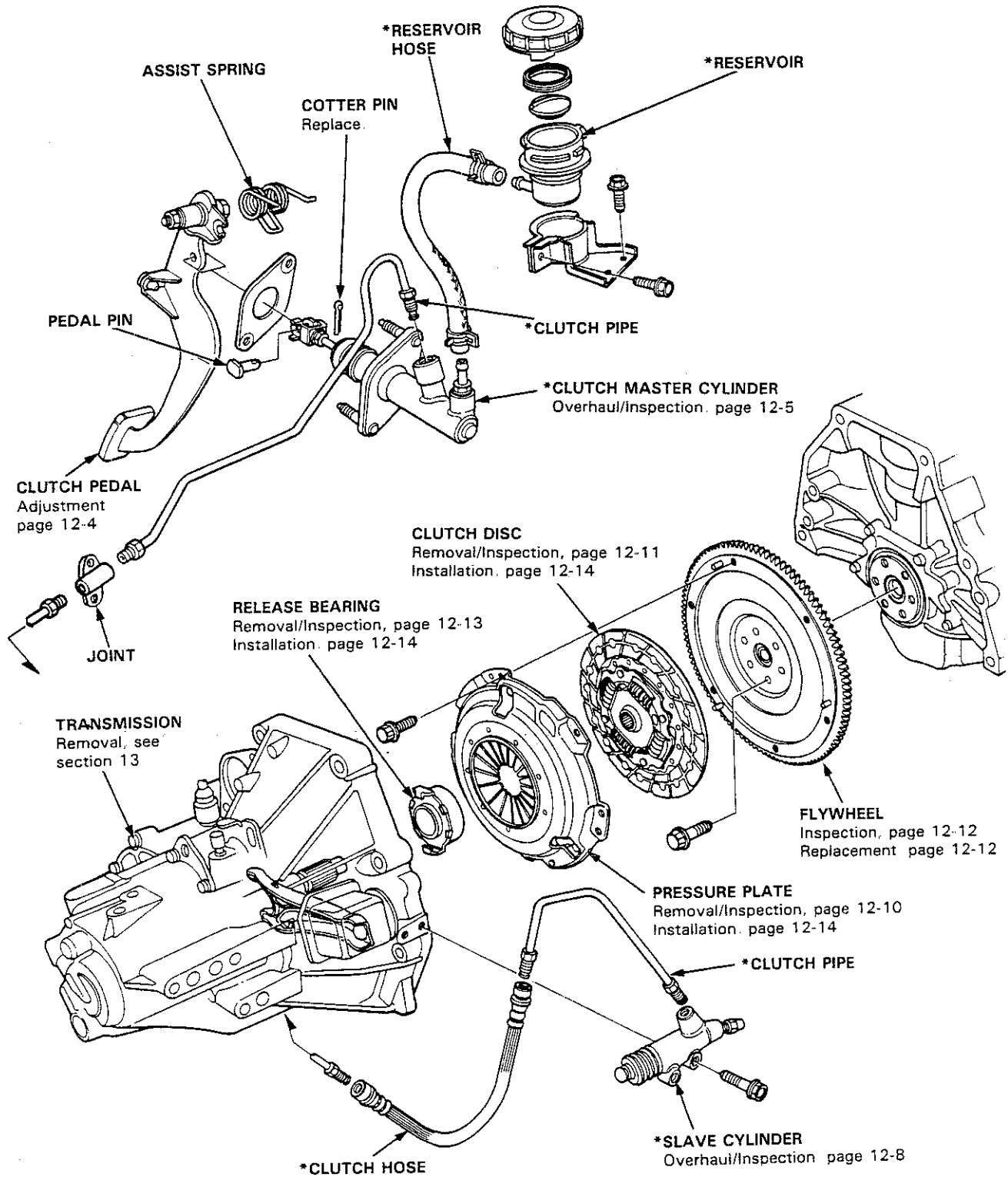

# Pedal Free Play

**NOTE:**

- The clutch is self-adjusting to compensate for wear
- Total clutch pedal free play is 12–21 mm (0.47–0.83 in).

**CAUTION:** If there is no clearance between the master cylinder piston and push rod, the release bearing is held against the diaphragm spring, which can result in clutch slippage or other clutch problems.

1. Loosen locknut A, and back off the pedal switch until it no longer touches the clutch pedal
2. Loosen locknut B, and turn the push rod in or out to get the specified stroke and height at the clutch pedal.
3. Tighten locknut B.
4. Thread the clutch pedal switch A in until it contacts the clutch pedal
5. Turn the switch in further 3/4 to 1 turn.
6. Tighten locknut A.

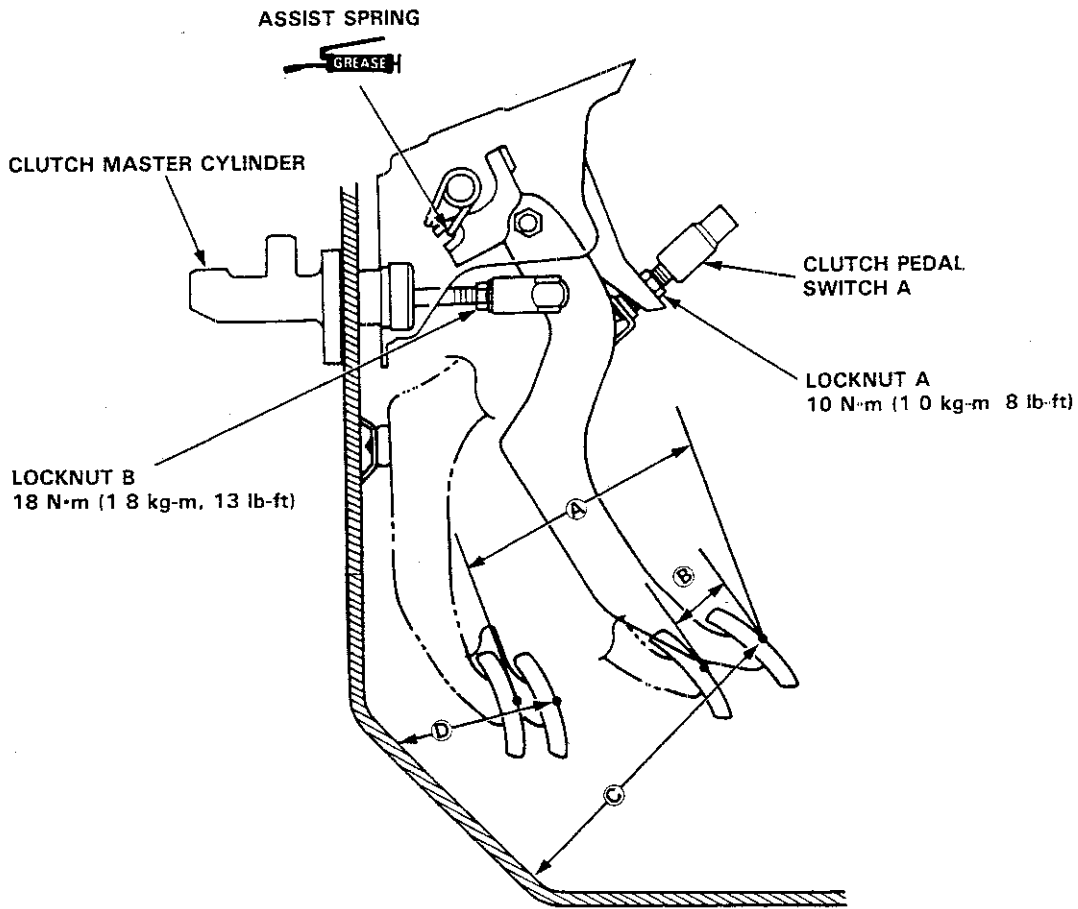

- Ⓐ (STROKE AT PEDAL): 130–140 mm (5.12–5.51 in)
- Ⓑ (PEDAL PLAY): 1.0–10.0 mm (0.04–0.37 in)
- Ⓒ (CLUTCH PEDAL HEIGHT): 164 mm (6.46 in)
- Ⓓ (CLUTCH PEDAL DISENGAGEMENT HEIGHT): 83 mm (3.27 in) minimum to the floor.



# Clutch Master Cylinder

## Overhaul/Inspection

NOTE: RHD type is shown.

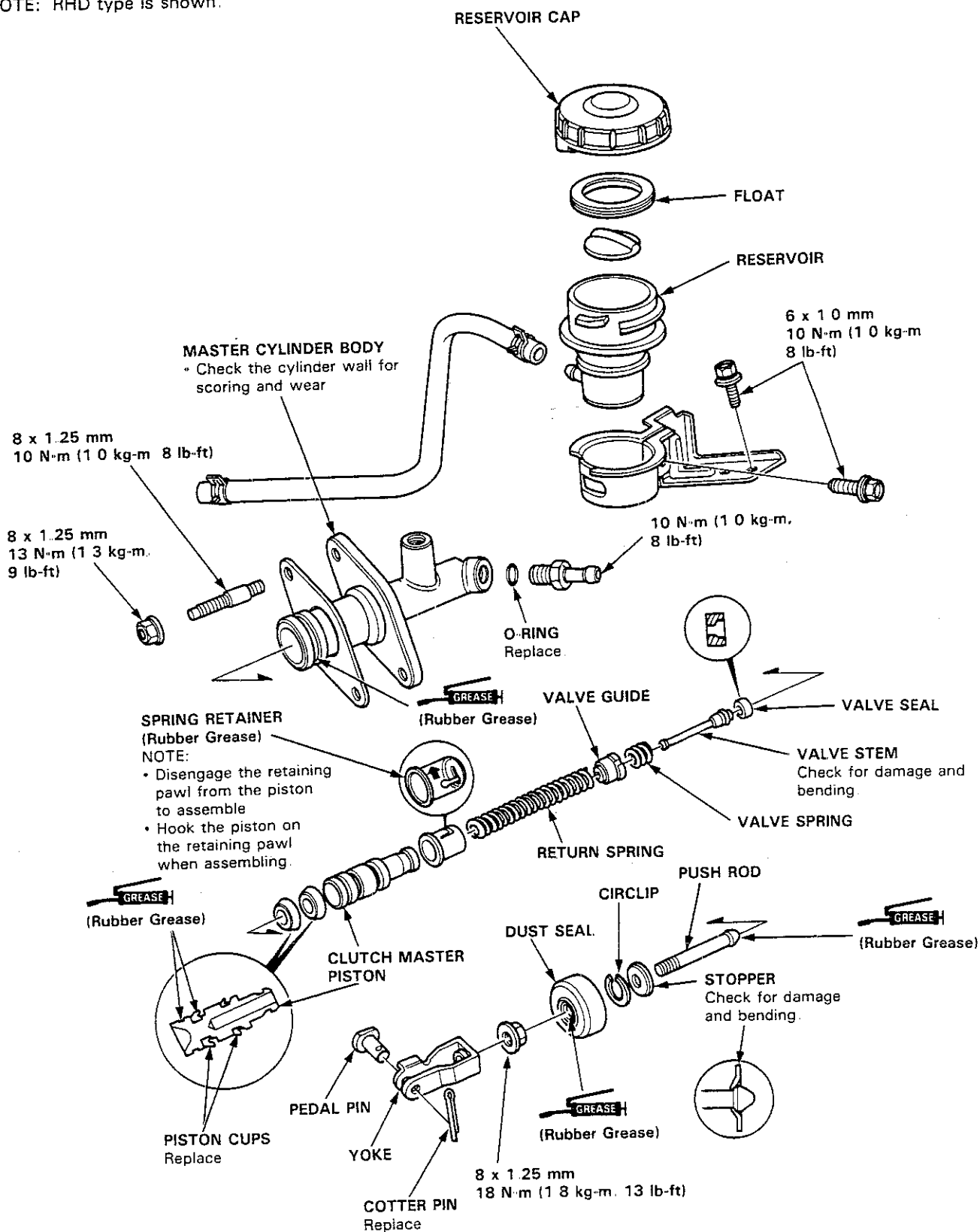

# Clutch Master Cylinder

## Removal/Installation

### CAUTION:

- Avoid spilling brake fluid on painted surfaces, as it may damage the finish.
- Plug the end of the clutch pipe and reservoir hose with a shop towel to prevent fluid from flowing out of the clutch pipe and reservoir hose after disconnecting

NOTE: LHD type is shown.

1. The brake fluid may be sucked out through the top of the master cylinder reservoir (see section 19)
2. Disconnect the clutch pipe and clutch hose from the clutch master cylinder

CLUTCH PIPE  
15 N·m (1.5 kg-m, 11 lb-ft)

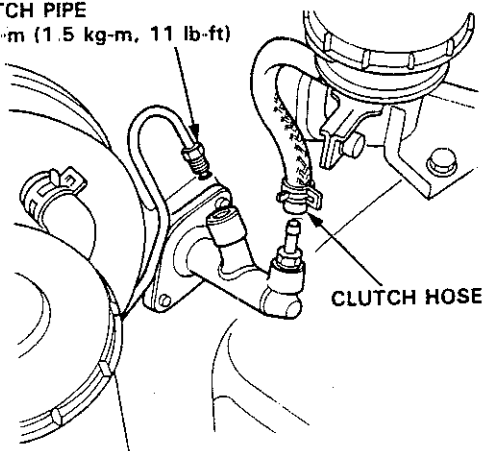

3. Pry out the cotter pin, and pull the pedal pin out of the yoke. Remove the nuts

NUTS  
13 N·m (1.3 kg-m, 9 lb-ft)

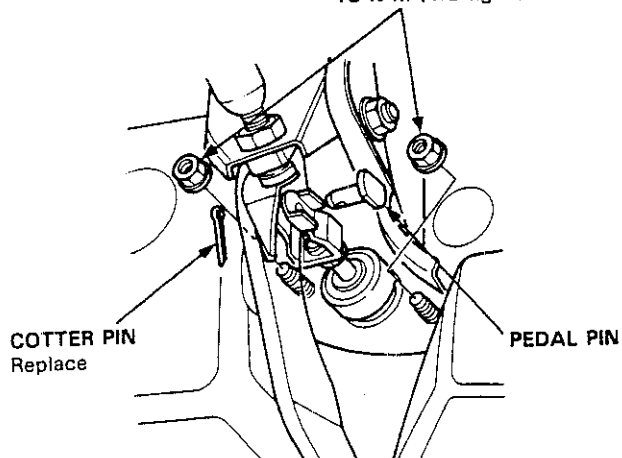

4. Remove the clutch master cylinder assembly.

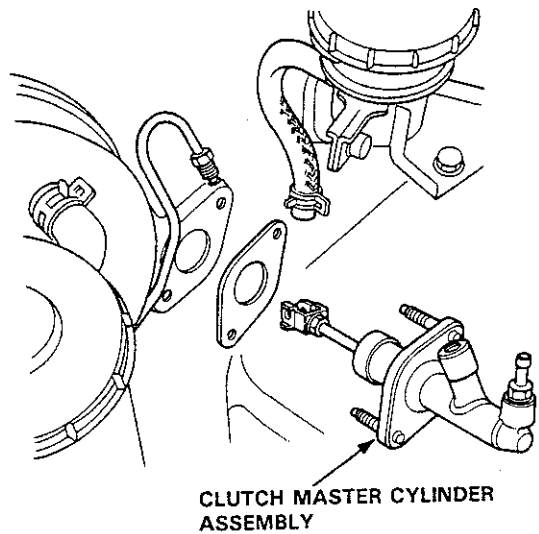

5. Install the clutch master cylinder in the reverse order of removal

NOTE: Bleed the clutch hydraulic system (see page 12-9).



## Disassembly

**CAUTION:** Avoid spilling brake fluid on paint as it may damage the finish.

1. Remove the dust seal from the master cylinder.
2. Pry the circlip off the master cylinder.

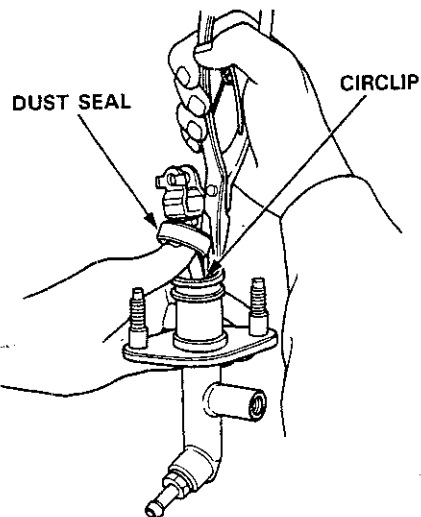

3. Carefully remove the piston by applying air pressure through the clutch line hose.

**CAUTION:**

- Hold a shop towel over the master cylinder, to stop the piston in case it comes out suddenly.
- Plug the end of the clutch hose port with a shop towel to prevent fluid from coming out.
- Clean all disassembled parts in solvent and blow through all ports and passages with compressed air.

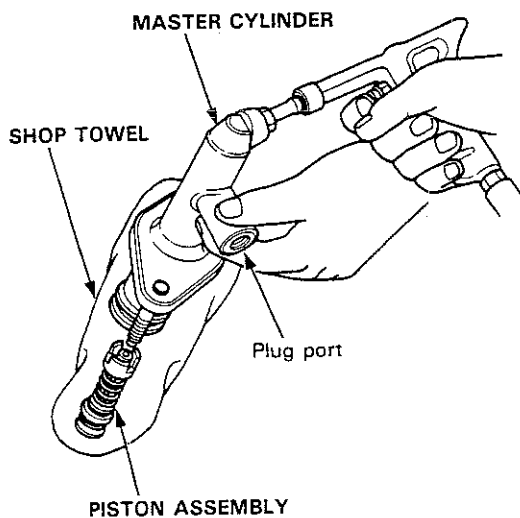

## Reassembly

**CAUTION:**

- Before assembling, make sure all parts are completely clean.
- Replace parts with new ones whenever specified to do so.
- Do not allow dust or water to enter the system.
- Do not mix different brands of brake fluid as they may not be compatible.
- Do not reuse the brake fluid which was drained out.
- Avoid spilling the brake fluid on painted surfaces, as it may damage the finish.

1. Assemble the piston with noting the proper direction of the parts (see page 12-5)
2. Apply grease to the parts (see page 12-5)
3. Slide the piston assembly into the master cylinder body.

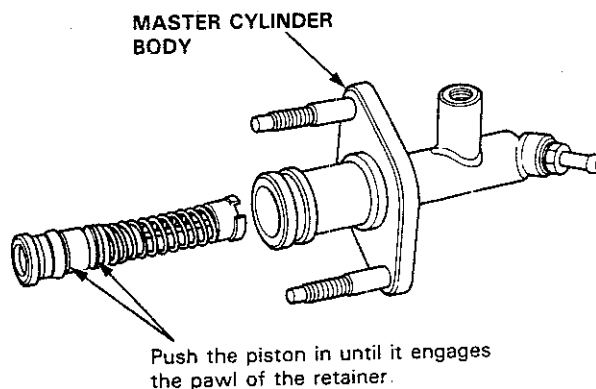

4. Install the circlip in the groove of the master cylinder body.

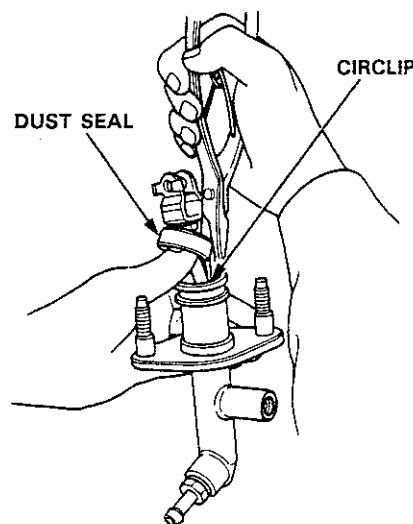

5. Install the dust seal.

# Slave Cylinder

## Overhaul/Inspection

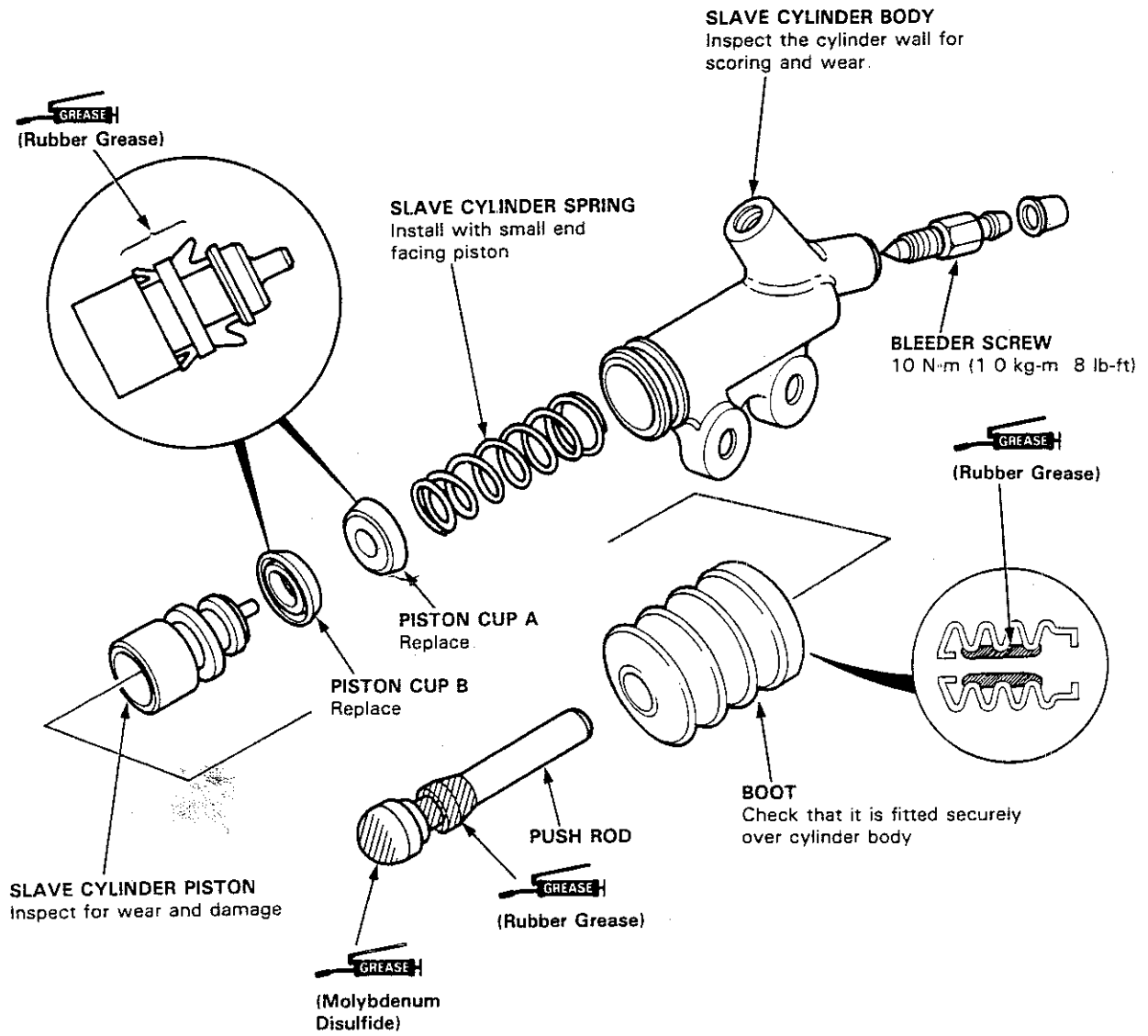





# Slave Cylinder

## Removal

1. Disconnect the clutch pipe from the slave cylinder.

### CAUTION:

- Avoid spilling brake fluid on the painted surfaces, as it may damage the finish.
- Plug the end of the clutch pipe with a shop towel to prevent brake fluid from coming out.

2. Remove the slave cylinder assembly from the clutch housing.

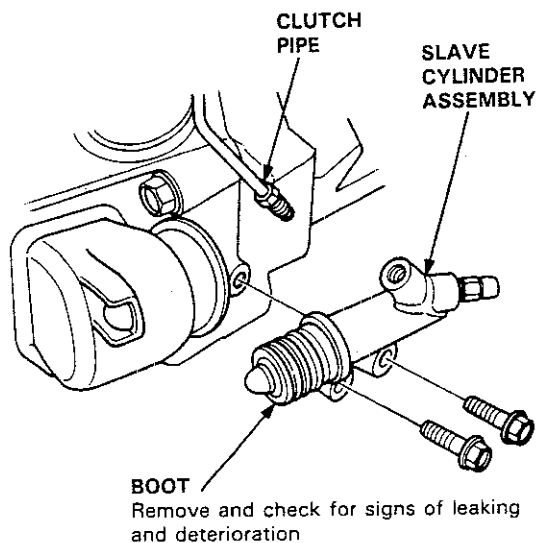

## Installation

1. Install the slave cylinder assembly on the clutch housing, then connect the clutch pipe

NOTE: Make sure the boot is installed on the slave cylinder.

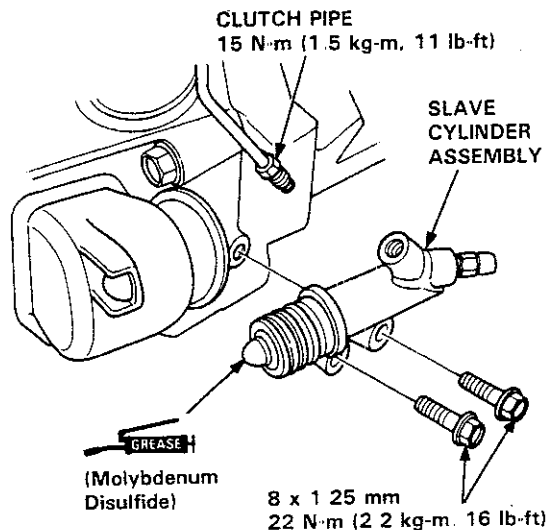

2. Bleed the clutch hydraulic system

- Attach a hose to the bleeder screw and suspend the hose in a container of brake fluid.
- Make sure there is an adequate supply of fluid at the master cylinder, then slowly pump the clutch pedal until no more bubbles appear at the bleeder hose.
- Refill the master cylinder fluid
- Use only DOT 3 or 4 brake fluid

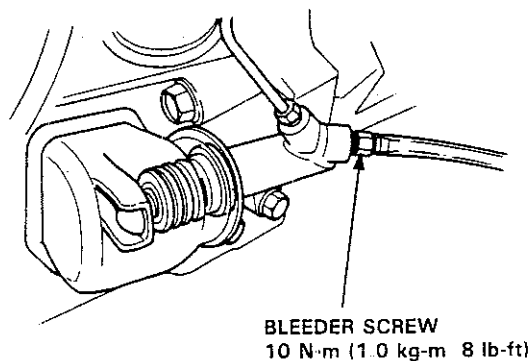

# Pressure Plate

## Removal/Inspection

1. Inspect the fingers of the diaphragm spring for wear at the release bearing contact area
2. Check the diaphragm spring fingers for height using the special tools and a feeler gauge

Standard (New): 0.8 mm (0.03 in) Min  
Service Limit: 1.0 mm (0.04 in) Max

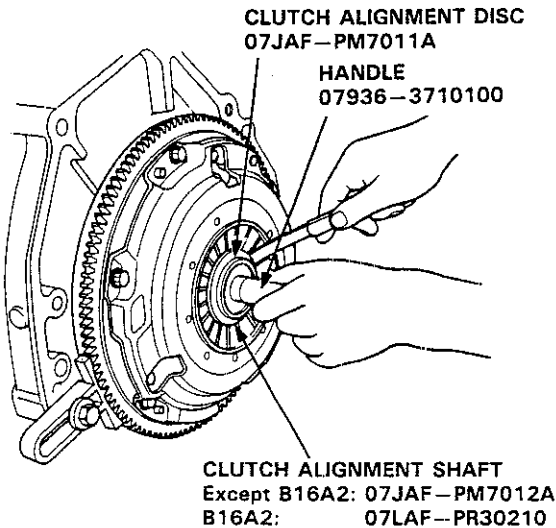

3. Install the ring gear holder, then insert the handle and Clutch Alignment Shaft as a set in the clutch disc.
4. To prevent warping, unscrew the pressure plate mounting bolts two turns at a time in a criss-cross pattern, then remove the pressure plate

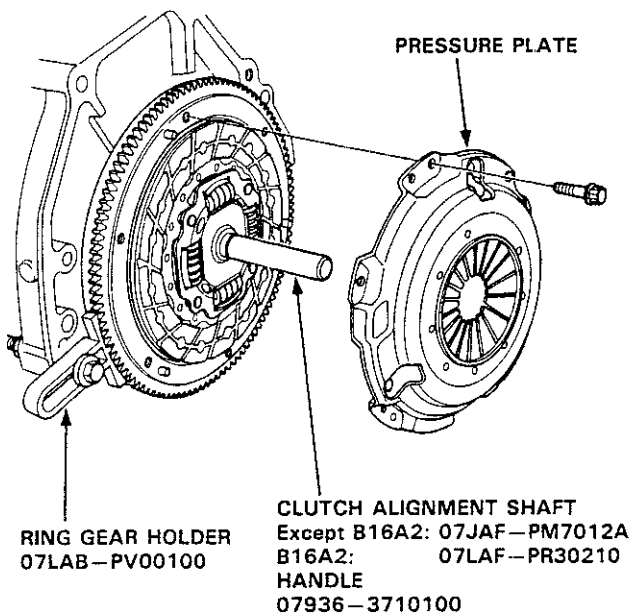

5. Inspect the pressure plate surface for wear, cracks, and burning
6. Inspect for warpage using a straight edge and feeler gauge. Measure across the pressure plate.

Standard (New): 0.03 mm (0.001 in) Min.  
Service Limit: 0.15 mm (0.006 in)

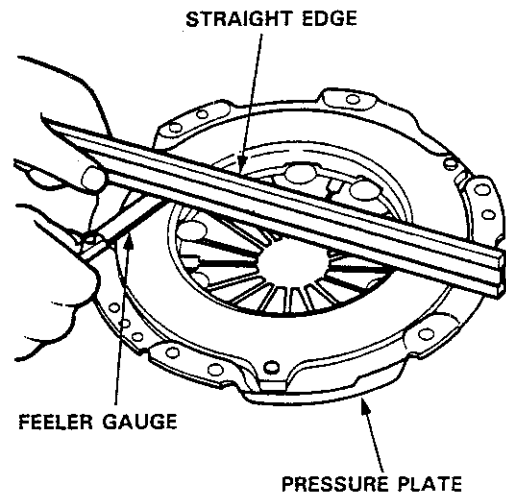



# Clutch Disc

## Removal/Inspection

1. Remove the clutch disc and special tools
2. Inspect lining of the clutch disc for signs of slipping or oil. If it is burned black or oil soaked, replace it.

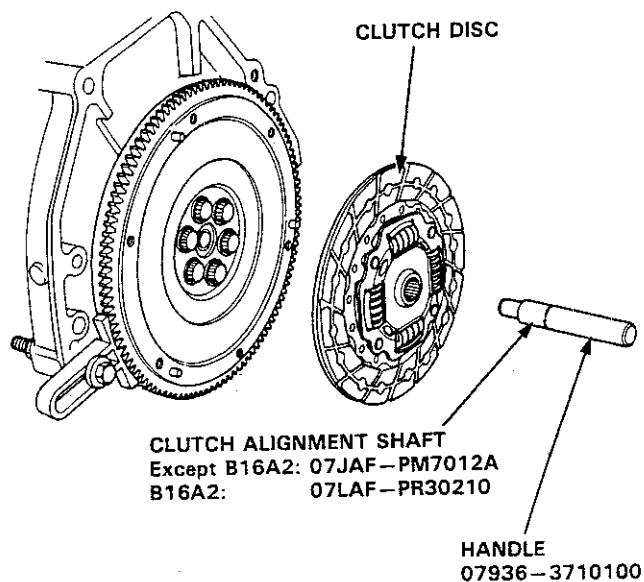

3. Measure the clutch disc thickness.

**Clutch Disc Thickness:**  
Standard (New): 8.4–9.1 mm (0.33–0.36 in)  
Service Limit: 6.0 mm (0.24 in)

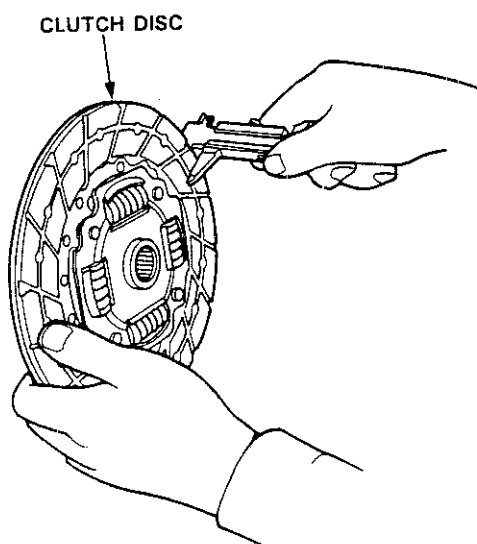

4. Measure the depth from the lining surface to the rivets, on both sides

**Rivet Depth:**  
Standard (New): 1.3 mm (0.051 in)  
Service Limit: 0.2 mm (0.008 in)

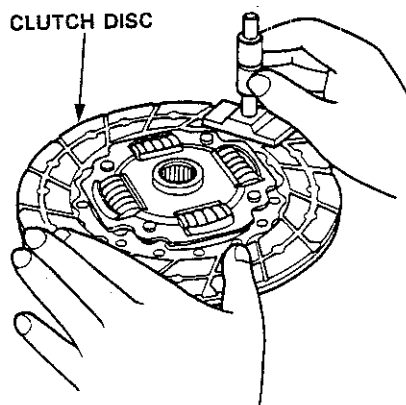

# Flywheel

## Inspection

1. Inspect the ring gear teeth for wear and damage
2. Inspect the clutch disc mating surface on the flywheel for wear, cracks, and burning.
3. Measure the flywheel runout using a dial indicator through at least two full turns. Push against the flywheel each time you turn it to take up the crankshaft thrust washer clearance.

NOTE: The runout can be measured with engine installed.

Standard (New): 0.05 mm (0.002 in) Max.  
Service Limit: 0.15 mm (0.006 in)

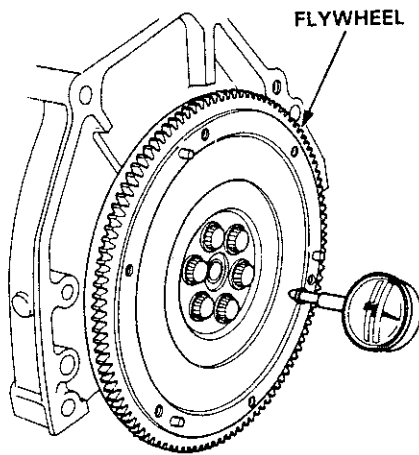

4. Turn the inner race of the flywheel bearing with your finger. The bearing should turn smoothly and quietly. Check that the bearing outer race fits tightly in the flywheel. If the race does not turn smoothly, quietly, or fit tightly in the flywheel, replace the bearing.

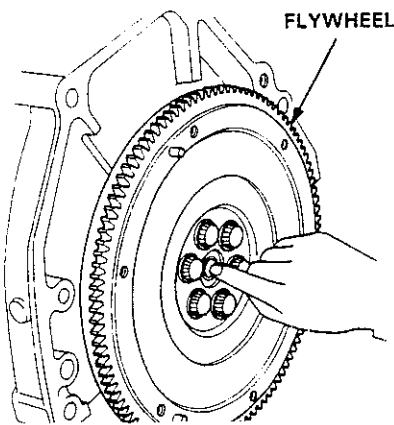

## Replacement

1. Install the ring gear holder
2. Remove the flywheel mounting bolts and the flywheel

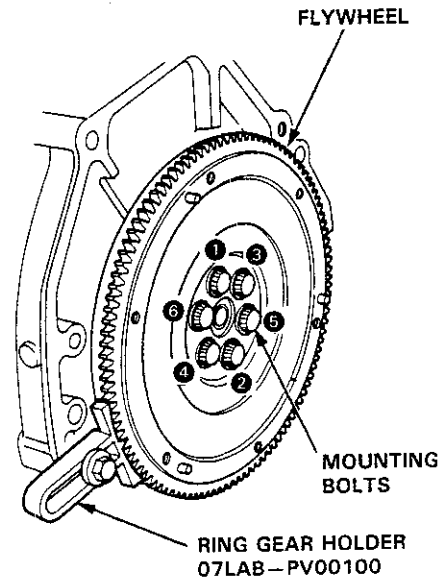

3. Remove the ball bearing from the flywheel.

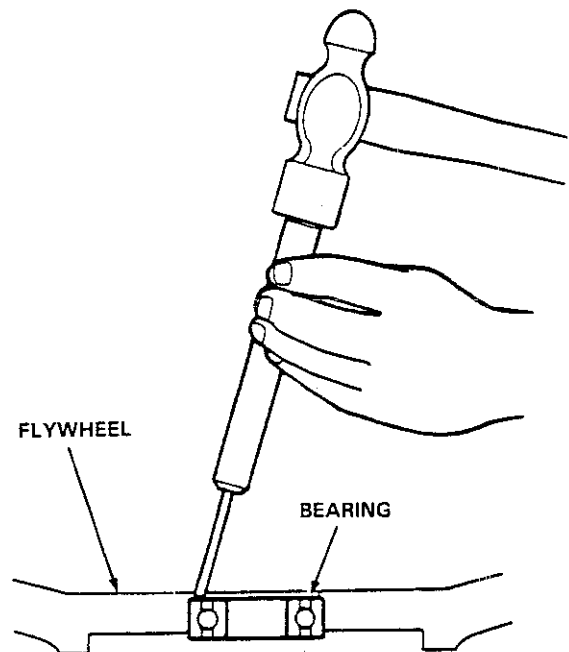



## Release Bearing

### Removal/Inspection

- 4 Drive the new bearing into the flywheel using the special tools.

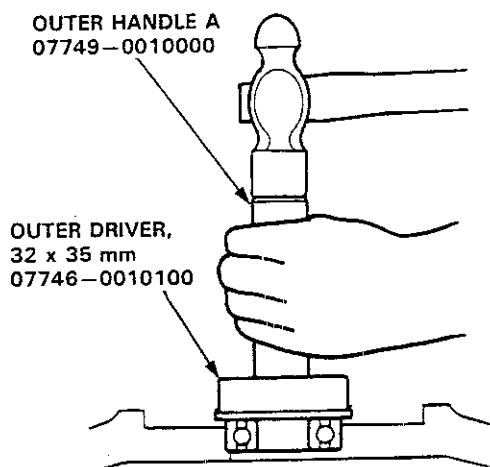

- 5 Align the hole in the flywheel with the crankshaft dowel pin and install the flywheel. Install the bolts finger-tight.
- 6 Install the special tool, then torque the flywheel mounting bolts in a criss-cross pattern, as shown.

Torque: 120 N·m (12.0 kg·m, 87 lb-ft)

Except B16A2:

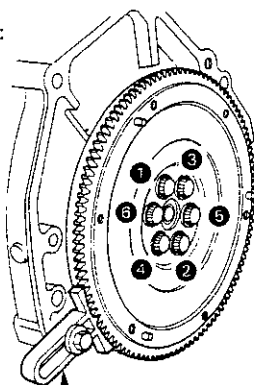

RING GEAR HOLDER  
07LAB-PV00100

B16A2:

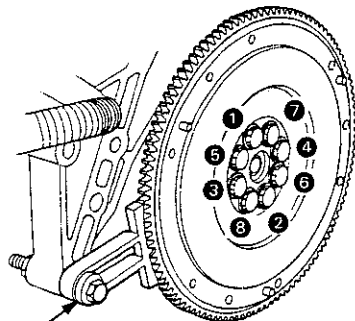

RING GEAR HOLDER  
07LAB-PV00100

- 1 Remove the boot from the clutch housing.
- 2 Remove the release fork from the clutch housing by squeezing the release fork set spring with pliers. Remove the release bearing.

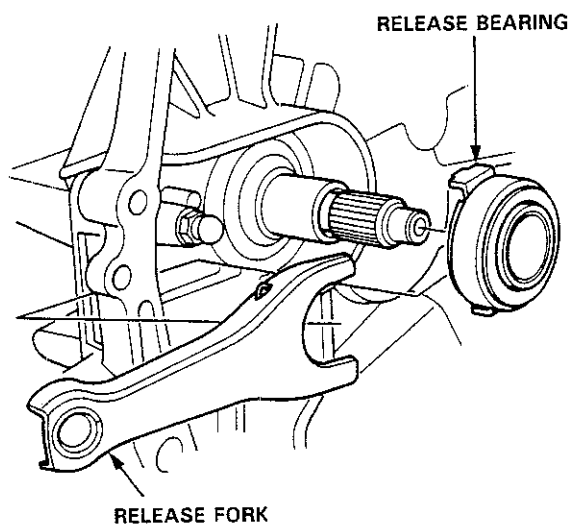

- 3 Check the release bearing for play by spinning it by hand.

**CAUTION:** The bearing is packed with grease. Do not wash it in solvent.

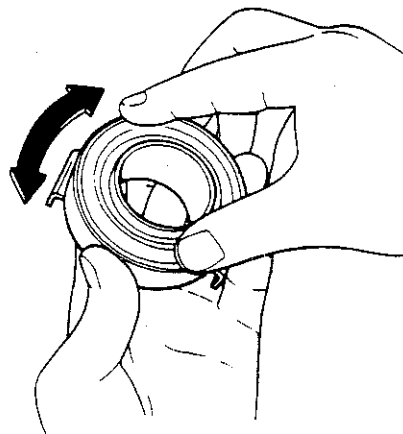

- 4 If there is excessive play, replace the bearing with a new one.

# Release Bearing

## Installation

1. With the release fork slid between the release bearing pawls; install the bearing on the mainshaft while inserting the release fork through the hole in the clutch housing
2. Align the detent of the release fork with the release fork bolt, then press the release fork over the release fork bolt

NOTE: Use only Super High Temp Urea Grease (P/N 08798-9002).

30 N·m (3.0 kg-m, 22 lb-ft)

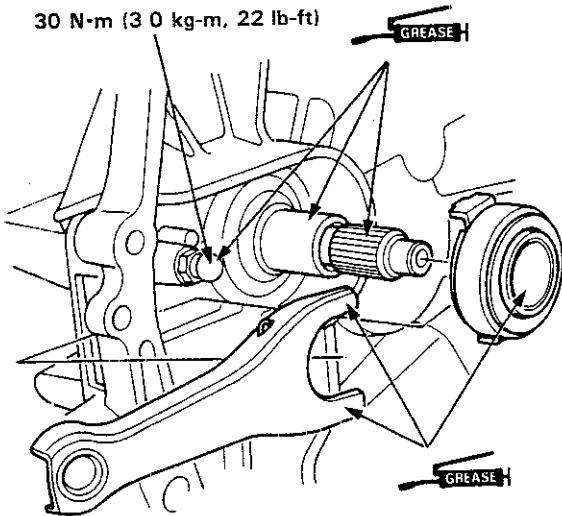

3. Move the release fork right and left to make sure that the fork fits properly against the bearing, and that the bearing slides smoothly.

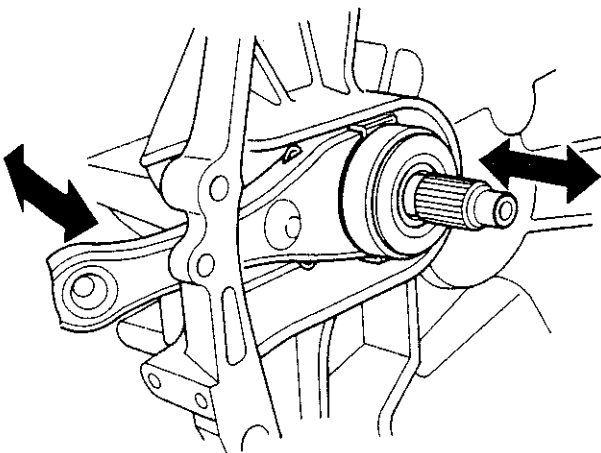

4. Install the boot.

# Clutch Disc, Pressure Plate

## Installation

1. Install the ring gear holder.
2. Install the clutch disc using the special tools

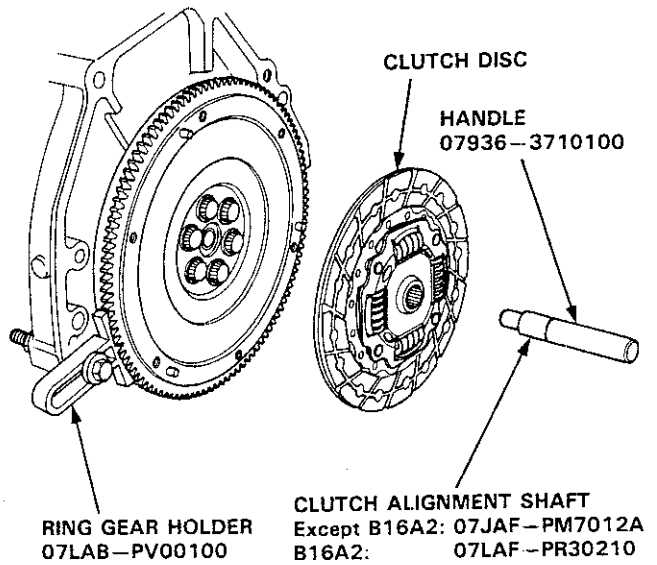

3. Install the pressure plate

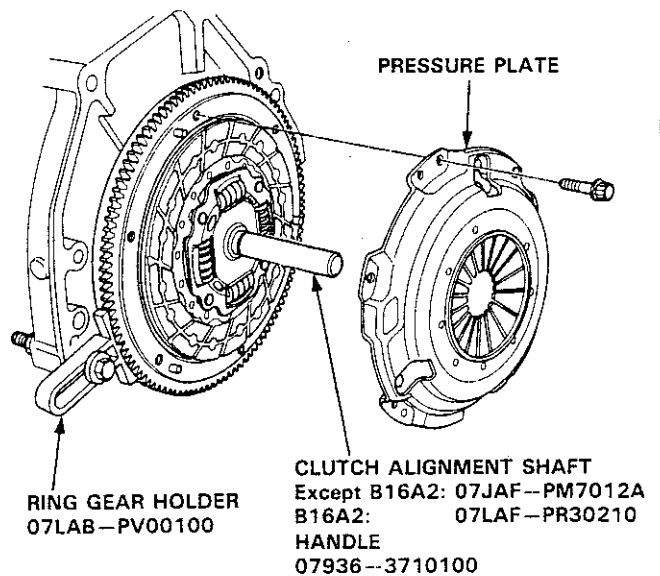



4. Torque the bolts in a criss-cross pattern as shown. Tighten them two turns at a time to prevent warping the diaphragm spring

Except B16A2:

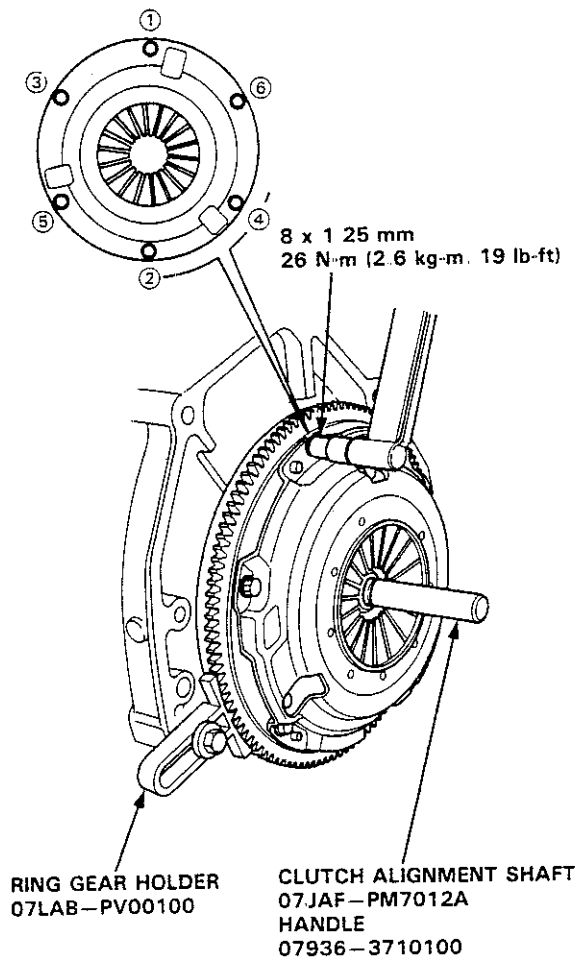

B16A2:

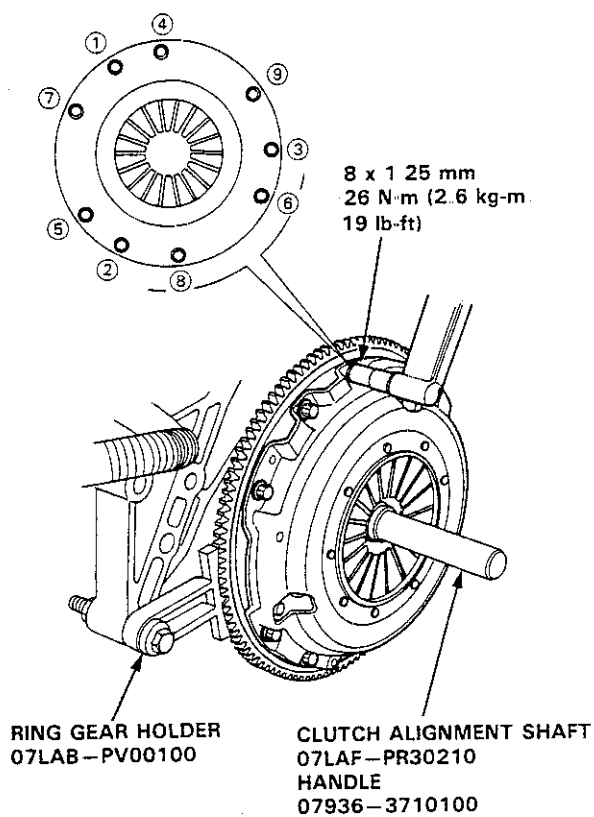

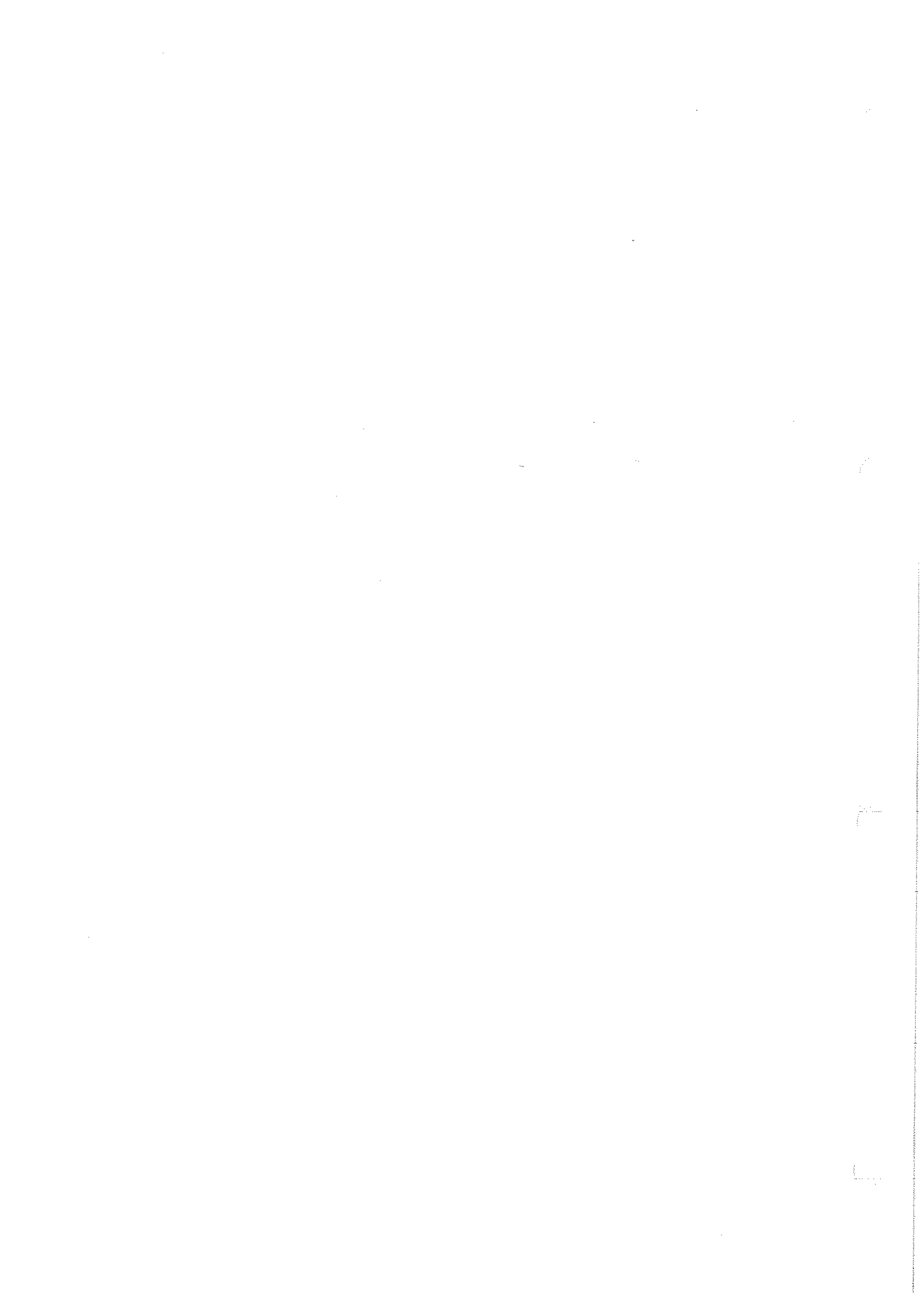



# S20 Model Manual Transmission

Special Tools .....	13-2	Shift Fork Assembly	
Maintenance .....	13-3	Disassembly/Reassembly .....	13-23
Back-up Light Switch		Clearance Inspection .....	13-24
Replacement .....	13-3	Synchro Sleeve, Synchro Hub	
Transmission Assembly		Inspection .....	13-25
Removal .....	13-4	Installation .....	13-25
Illustrated Index .....	13-8	Synchro Ring, Gear	
Transmission Housing		Inspection .....	13-26
Removal .....	13-10	Shift Rod	
Reverse Shift Fork		Removal .....	13-27
Clearance Inspection .....	13-11	Clutch Housing Bearing	
Reverse Idler Gear		Replacement .....	13-28
Removal .....	13-12	Mainshaft Thrust Shim	
Mainshaft, Countershaft, Shift Fork		Adjustment .....	13-30
Disassembly .....	13-12	Transmission	
Mainshaft Assembly		Reassembly .....	13-33
Index .....	13-13	Transmission Assembly	
Clearance Inspection .....	13-14	Installation .....	13-37
Disassembly .....	13-15	Gearshift Mechanism	
Inspection .....	13-16	Overhaul .....	13-41
Reassembly .....	13-17		
Countershaft Assembly			
Index .....	13-18		
Clearance Inspection .....	13-19		
Disassembly .....	13-20		
Inspection .....	13-21		
Reassembly .....	13-21		



# Special Tools

## Special Tools

Ref. No.	Tool Number	Description	Qty	Remarks
①	07GAJ-PG20102	Mainshaft Clearance Inspection Tool Set	1	
①-1	07GAJ-PG20110	Mainshaft Holder	(1)	Component Tools
①-2	07GAJ-PG20120	Collar	(1)	
①-3	07GAJ-PG20130	Mainshaft Base	(1)	
②	07JAC-PH80000	Adjustable Bearing Remover Set	1	
②-1	07JAC-PH80100	Bearing Remover Attachment	(1)	Component Tools
②-2	07JAC-PH80200	Remover Handle Assembly	(1)	
②-3	07741-0010201	Remover Weight	(1)	
③	07LGC-0010100	Snap Ring Plier	1	
④	07744-0010200	Pin Driver, 3.0 mm	1	
⑤	07744-0010400	Pin Driver, 5.0 mm	1	
⑥	07744-0010600	Pin Driver, 8.0 mm	1	
⑦	07746-0010300	Outer Driver, 42 x 47 mm	1	
⑧	07746-0010400	Outer Driver, 52 x 55 mm	1	
⑨	07746-0030100	Inner Handle C	1	
⑩	07746-0030300	Inner Driver 30 mm	1	
⑪	07746-0030400	Inner Driver, 35 mm	1	
⑫	07749-0010000	Outer Handle A	1	
⑬	07979-PJ40001	Magnet Stand Base	1	

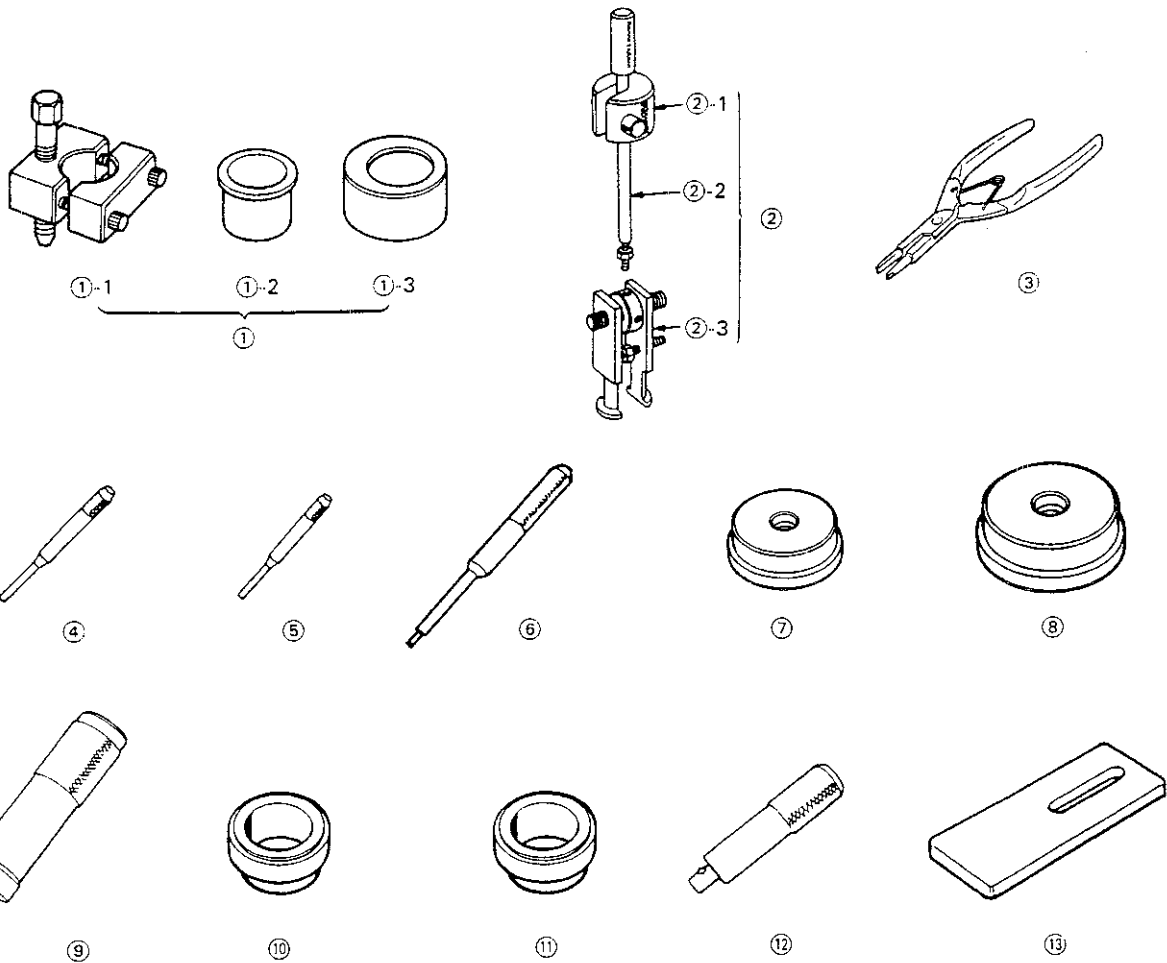

## **Manual Transmission**

### **S20 Model**

**Manual Transmission ..... 13-1**

### **Y21 Model**

**Manual Transmission ..... 13-43**



I



# Maintenance

## Transmission Oil

NOTE: Check the oil at operating temperature, engine OFF, and the car on level ground

1. Remove the oil filler plug, then check the level and condition of the oil.

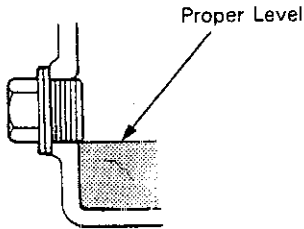

2. The oil level must be up to the filler hole. If it is below the hole, add oil until it runs out, then reinstall the oil filler plug.
3. If the oil is dirty, remove drain plug and drain transmission oil.
4. Reinstall the drain plug with a new washer, and refill to proper level.

NOTE: The drain plug washer should be replaced at every oil change.

5. Reinstall the oil filler plug with a new washer

### Oil Capacity

1.8 ℓ (1.9 U.S. qt , 1.6 Imp qt ) at oil change.  
 1.9 ℓ (2.0 U.S. qt , 1.7 Imp qt ) at overhaul.

Use only SAE 10W-30 or 10W-40. SF or SG grade

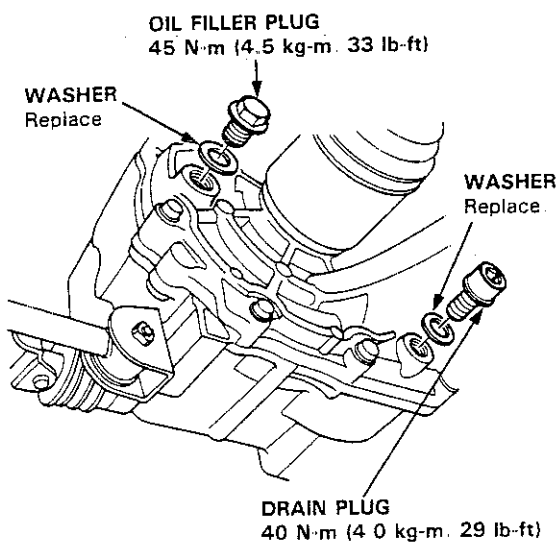

# Back-up Light Switch

## Replacement

NOTE: To check the switch, see section 23

1. Disconnect the connector, then remove the switch connector from the connector clamp
2. Remove the switch.
3. Install the new washer and switch.

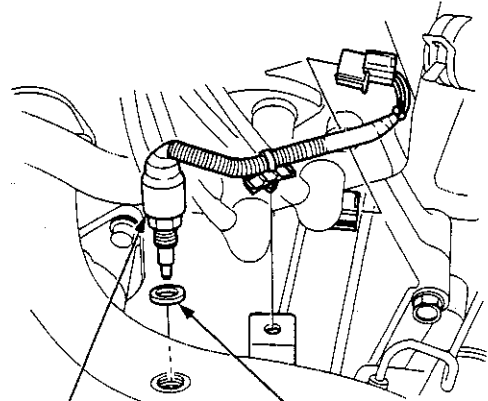

**BACK-UP LIGHT SWITCH**  
 25 N·m (2.5 kg-m, 18 lb-ft)

**WASHER**  
 Replace

# Transmission Assembly

## Removal

### ⚠ WARNING

- Make sure jacks and safety stands are placed properly, and hoist brackets are attached to the correct position on the engine.
- Apply parking brake and block rear wheels so the car will not roll off stands and fall on you while working under it

**CAUTION:** Use fender covers to avoid damaging painted surfaces.

1. Disconnect the negative (-) and positive (+) cables from the battery
2. Remove the resonator, air flow tube, and air cleaner housing

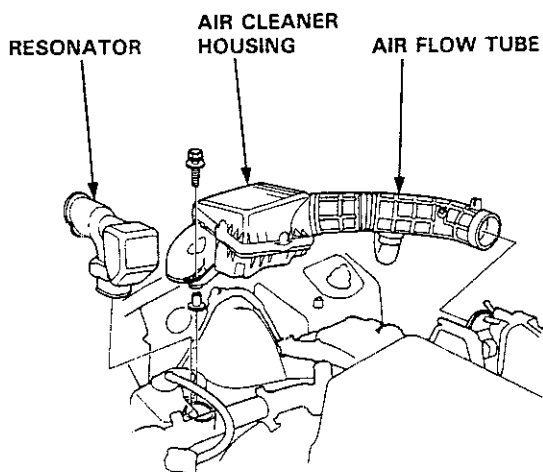

3. Disconnect the starter cables and transmission ground wire.
4. Remove the engine wire harness clamp.
5. Disconnect the back-up light switch and vehicle speed sensor connectors.

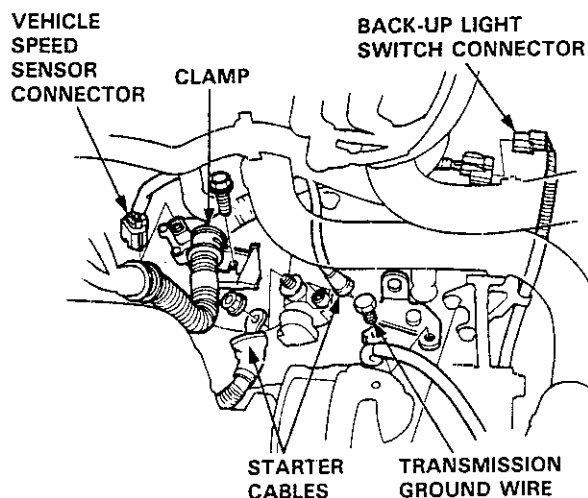

6. Remove the clutch pipe bracket and slave cylinder

**NOTE:** Do not operate the clutch pedal once the slave cylinder has been removed

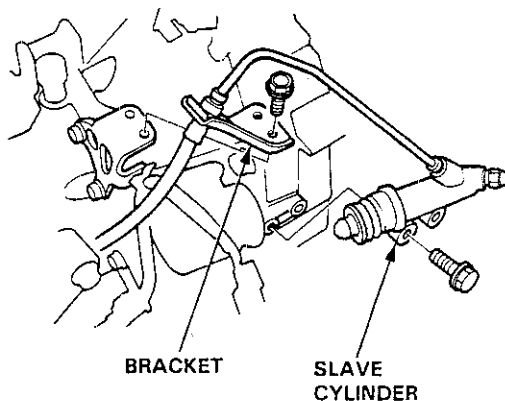



7 Remove the four upper transmission mounting bolts.

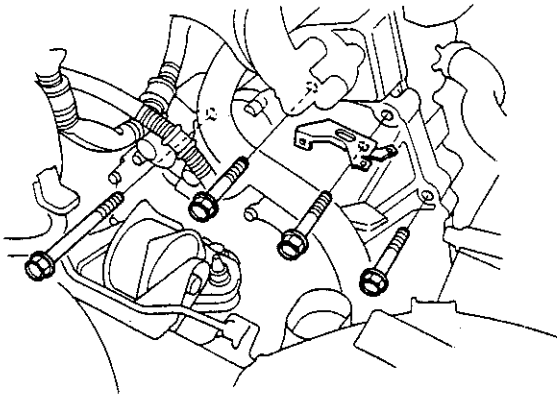

8 Remove the driveshafts and intermediate shaft (see section 16)

NOTE: Coat all precision finished surfaces with clean engine oil or grease. Tie plastic bags over the driveshaft ends.

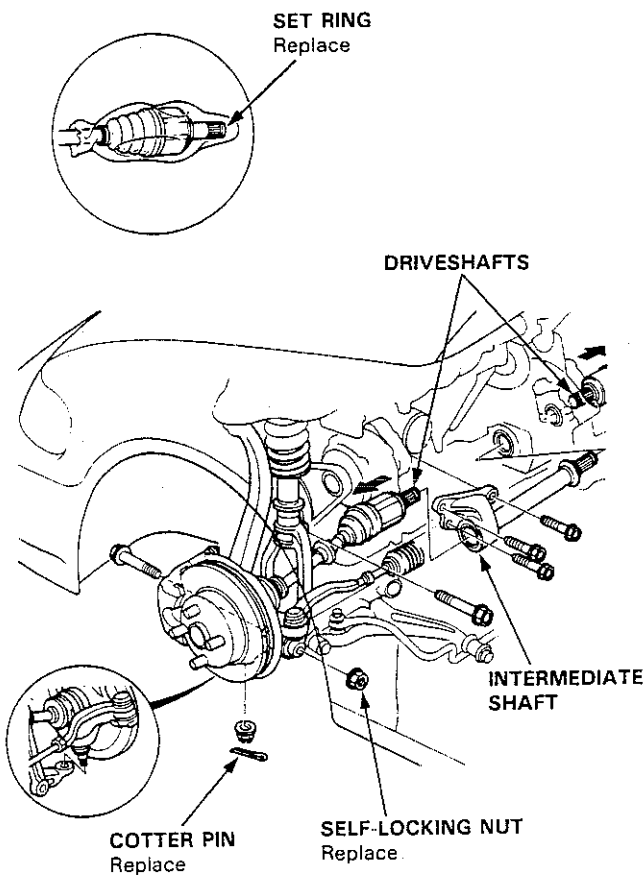

9. Disconnect the connector, then remove exhaust pipe A.

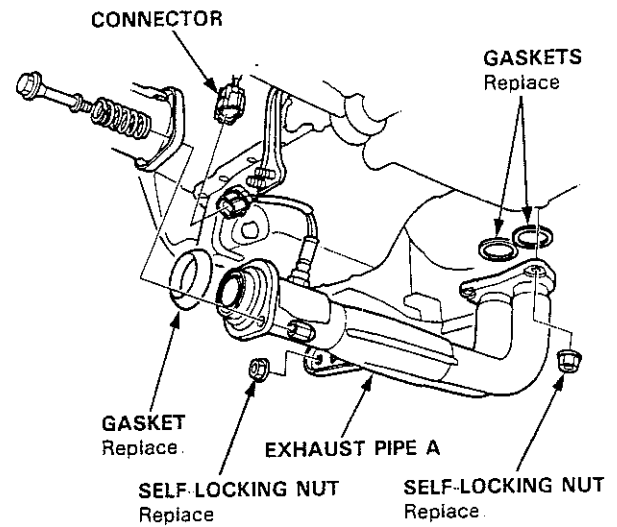

10. Remove the change rod and change extension

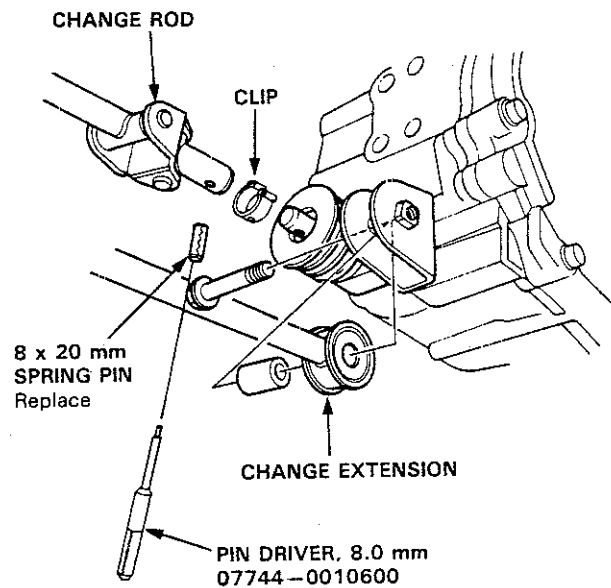

(cont'd)

# Transmission Assembly

## Removal (cont'd)

11. Remove the splash guard and front stopper bracket.

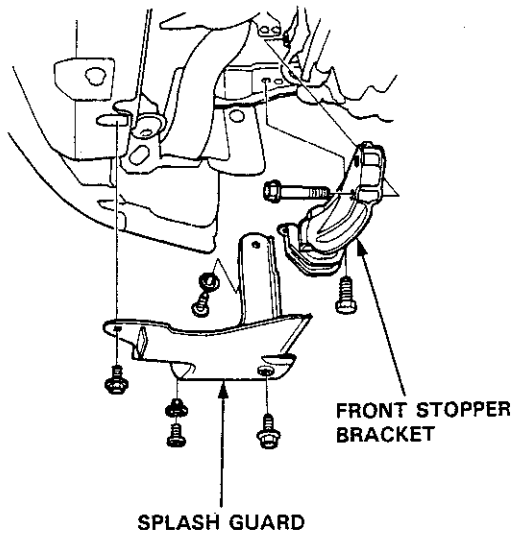

12. Install the bolts in the cylinder head and attach a chain hoist to the bolts, then lift the engine slightly to unload the mounts.

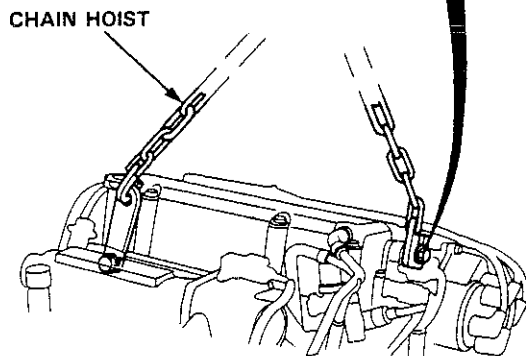
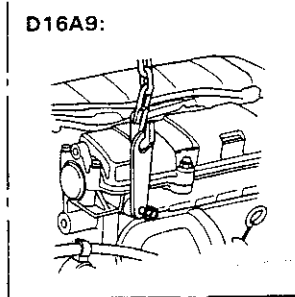

13. Place a jack under the transmission.

14. Remove the transmission side mount.

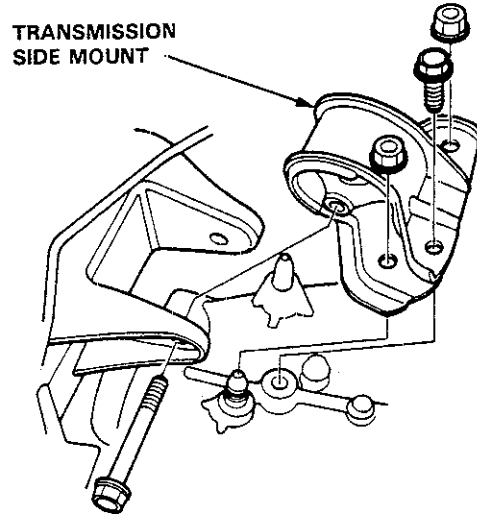

15. Remove engine stiffeners and the clutch cover.

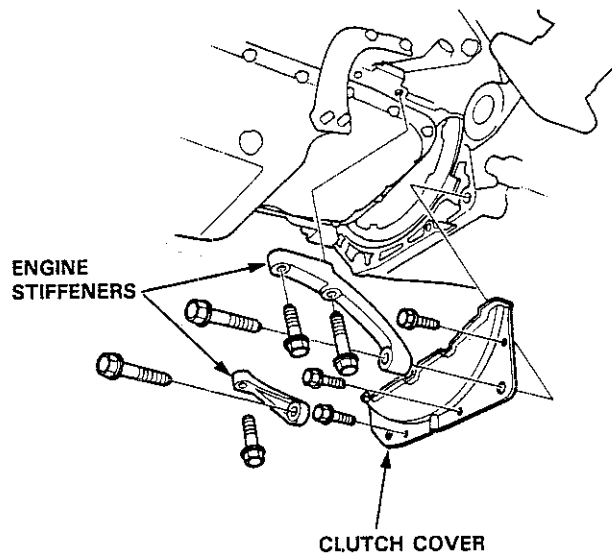





16. Remove the transmission rear mount bolts and transmission mounting bolts
17. Pull the transmission away from the engine until it clears the mainshaft, then lower it on the transmission jack.

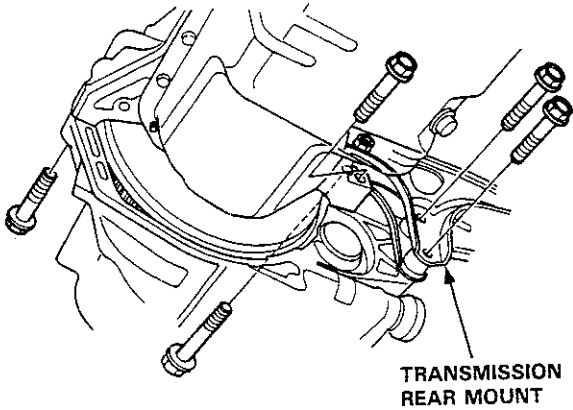

# Illustrated Index

Refer to the drawing below for the transmission disassembly/reassembly.  
Clean all parts thoroughly in solvent and dry with compressed air

 Lubricate all parts with oil before reassembly.

NOTE: This transmission uses no gaskets between the major housings; use P/N OY740-99986 sealant. Assemble the housings within 20 minutes after applying the sealant and allow it to cure at least 30 minutes after assembly before filling the transmission with oil.

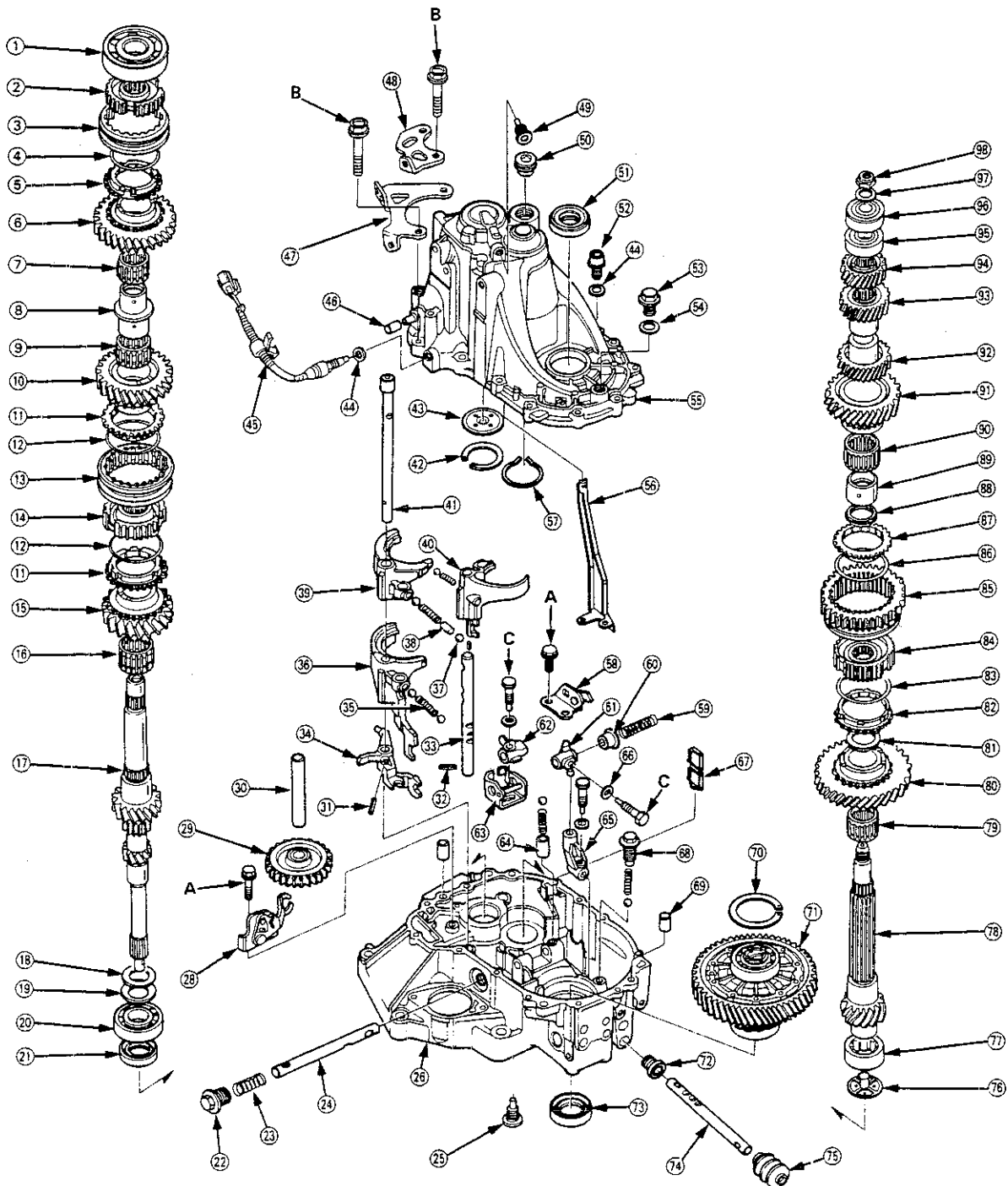



NOTE: Always clean the magnet (67) whenever the transmission housing is disassembled.

Torque Value
A - 15 N·m (1.5 kg-m, 11 lb-ft)
B - 28 N·m (2.8 kg-m, 21 lb-ft)
C - 32 N·m (3.2 kg-m, 23 lb-ft)

- ① BALL BEARING
- ② 5TH SYNCHRO HUB
- ③ 5TH SYNCHRO SLEEVE
- ④ SYNCHRO SPRING
- ⑤ SYNCHRO RING
- ⑥ 5TH GEAR
- ⑦ 32 x 37 x 23.5 mm  
NEEDLE BEARING
- ⑧ SPACER COLLAR
- ⑨ 34 x 39 x 23 mm  
NEEDLE BEARING
- ⑩ 4TH GEAR
- ⑪ SYNCHRO RING
- ⑫ SYNCHRO SPRING
- ⑬ 3RD/4TH SYNCHRO SLEEVE
- ⑭ 3RD/4TH SYNCHRO HUB
- ⑮ 3RD GEAR
- ⑯ 34 x 39 x 27.5 mm  
NEEDLE BEARING
- ⑰ MAINSHAFT
- ⑱ WASHER
- ⑲ SPRING WASHER
- ⑳ BALL BEARING
- ㉑ 26 x 42 x 7 mm OIL SEAL  
Replace
- ㉒ 28 mm PLUG BOLT  
55 N·m (5.5 kg-m, 40 lb-ft)
- ㉓ 1ST/2ND SELECT SPRING
- ㉔ SHIFT ARM SHAFT
- ㉕ INTERLOCK GUIDE BOLT  
40 N·m (4.0 kg-m, 29 lb-ft)
- ㉖ CLUTCH HOUSING
- ㉗ REVERSE SHIFT HOLDER
- ㉘ REVERSE IDLER GEAR
- ㉙ REVERSE IDLER GEAR SHAFT
- ㉚ 5 x 22 mm SPRING PIN  
Replace
- ㉛ 3 x 12 mm SPRING PIN  
Replace
- ㉜ 1ST/2ND SHIFT FORK SHAFT
- ㉝ 5TH/REVERSE SHIFT PIECE
- ㉞ SPRING

- ㉟ 3RD/4TH SHIFT FORK
- ㊱ STEEL BALL
- ㊲ 5 x 10 mm ROLLER
- ㊳ 5TH SHIFT FORK
- ㊴ 1ST/2ND SHIFT FORK
- ㊵ 5TH/REVERSE SHIFT FORK  
SHAFT
- ㊶ 70 mm THRUST SHIM  
Selection, page 13-28
- ㊷ OIL GUIDE PLATE
- ㊸ WASHER Replace
- ㊹ BACK-UP LIGHT SWITCH  
25 N·m (2.5 kg-m, 18 lb-ft)
- ㊺ BREATHER CAP
- ㊻ RELEASE PIPE STAY
- ㊼ TRANSMISSION HANGER B
- ㊽ 10 mm SEALING BOLT  
10 N·m (1.0 kg-m, 8 lb-ft)
- ㊾ 32 mm SEALING BOLT  
25 N·m (2.5 kg-m, 18 lb-ft)
- ㊿ 35 x 62 x 8 mm OIL SEAL (\*1)  
40 x 62 x 9 mm OIL SEAL (\*2)  
Replace
- ① OIL DRAIN PLUG  
40 N·m (4.0 kg-m, 29 lb-ft)
- ② OIL FILLER PLUG  
45 N·m (4.5 kg-m, 33 lb-ft)
- ③ WASHER Replace
- ④ TRANSMISSION HOUSING
- ⑤ OIL GUTTER PLATE
- ⑥ 52 mm SNAP RING
- ⑦ REVERSE LOCK CAM
- ⑧ REVERSE SELECT SPRING
- ⑨ REVERSE SELECT RETAINER
- ⑩ SHIFT ARM C
- ⑪ SHIFT ARM B
- ⑫ INTERLOCK
- ⑬ COLLAR
- ⑭ SHIFT ARM A
- ⑮ SPRING WASHER
- ⑯ MAGNET
- ⑰ SET BALL SPRING BOLT  
22 N·m (2.2 kg-m, 16 lb-ft)

- ⑱ 14 x 20 mm DOWEL PIN
- ⑳ 80 mm THRUST SHIM  
Selection, See section 15
- ㉑ DIFFERENTIAL ASSEMBLY  
See section 15
- ㉒ 14 x 25 x 17.5 mm OIL SEAL  
Replace
- ㉓ 35 x 56 x 8 mm OIL SEAL  
Replace
- ㉔ SHIFT ROD
- ㉕ BOOT
- ㉖ OIL GUIDE PLATE
- ㉗ 30 x 55 x 21 mm  
NEEDLE BEARING
- ㉘ COUNTERSHAFT
- ㉙ 36 x 41 x 25.5 mm  
NEEDLE BEARING
- ㉚ 1ST GEAR
- ㉛ FRICTION DAMPER
- ㉜ SYNCHRO RING
- ㉝ SYNCHRO SPRING
- ㉞ 1ST/2ND SYNCHRO HUB
- ㉟ REVERSE GEAR
- ① SYNCHRO SPRING
- ② SYNCHRO RING
- ③ FRICTION DAMPER
- ④ DISTANCE COLLAR
- ⑤ 39 x 44 x 27 mm  
NEEDLE BEARING
- ⑥ 2ND GEAR
- ⑦ 3RD GEAR
- ⑧ 4TH GEAR
- ⑨ 5TH GEAR
- ⑩ NEEDLE BEARING
- ⑪ BALL BEARING
- ⑫ SPRING WASHER
- ⑬ LOCKNUT  
110--0--110 N·m  
11.0--0--11.0 kg-m.  
80--0--80 lb-ft

\*1: D16Z6 D16Z7

\*2: D16A9

# Transmission Housing

## Removal

NOTE: Place the clutch housing on two pieces of wood thick enough to keep the mainshaft from hitting the workbench.

1. Remove the back-up light switch
2. Remove the transmission hanger B
3. Loosen the transmission housing attaching bolts in a criss-cross pattern, then remove them.

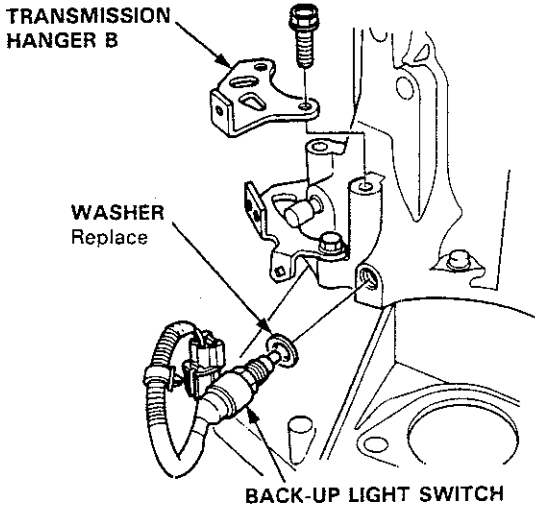

4. Remove the 32 mm sealing bolt
5. Expand the snap ring on the countershaft ball bearing and remove it from the groove using a pair of snap ring plier

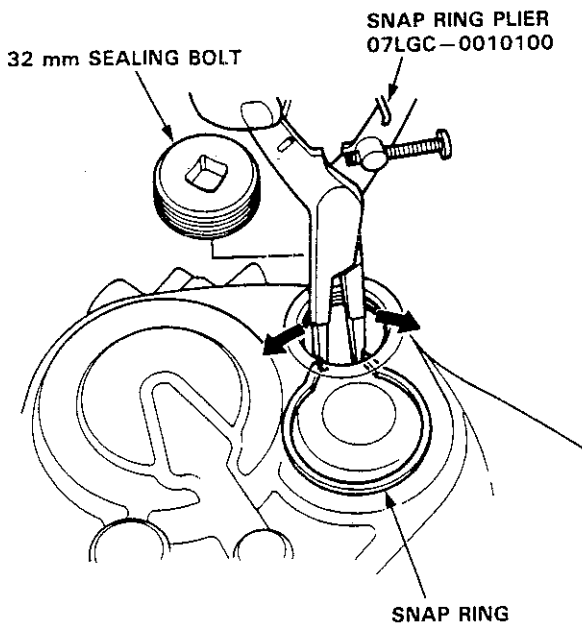

6. Separate the transmission housing from the clutch housing and wipe it clean of the sealant
7. Remove the thrust shim and oil guide plate from the transmission housing.

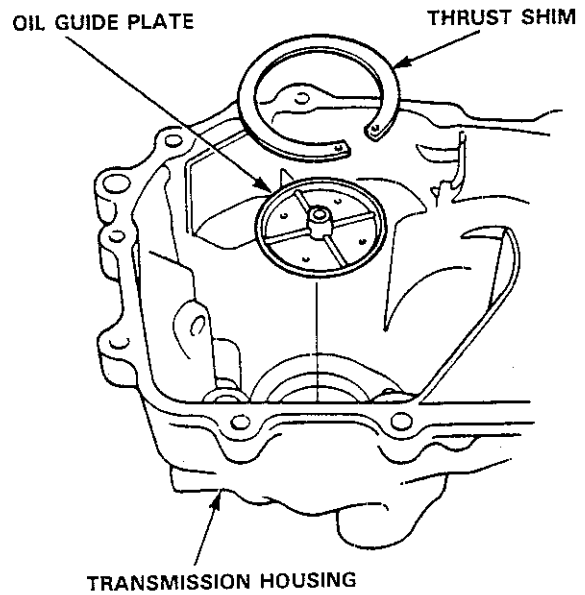

8. Remove the 10 mm sealing bolt and oil gutter plate

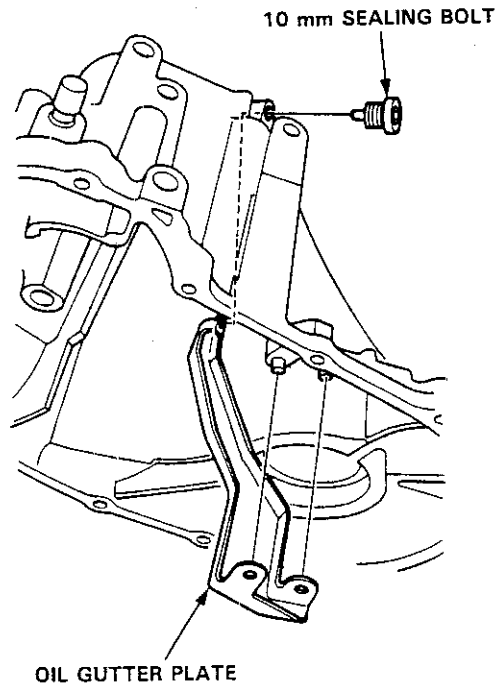



# Reverse Shift Fork

## Clearance Inspection

- 1 Measure the clearance between the reverse shift fork and shift piece pin.

**Standard:** 0.05–0.35 mm (0.002–0.014 in)  
**Service Limit:** 0.5 mm (0.020 in)

REVERSE SHIFT FORK

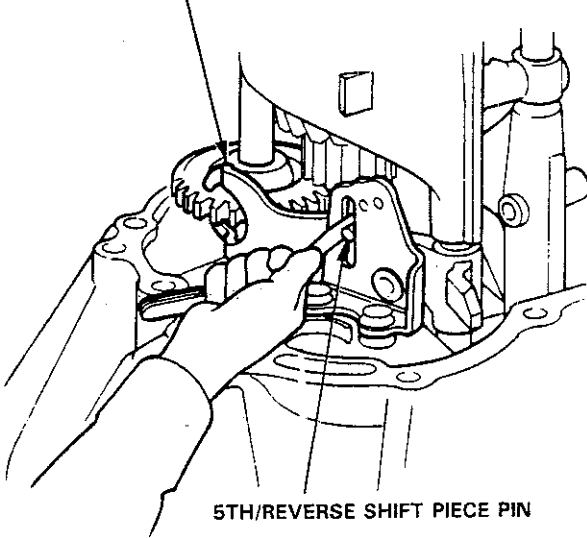

5TH/REVERSE SHIFT PIECE PIN

2. If the clearance exceeds the service limit, measure the width of the groove in the reverse shift holder

**Standard:** 7.05–7.25 mm (0.278–0.285 in)

REVERSE SHIFT FORK

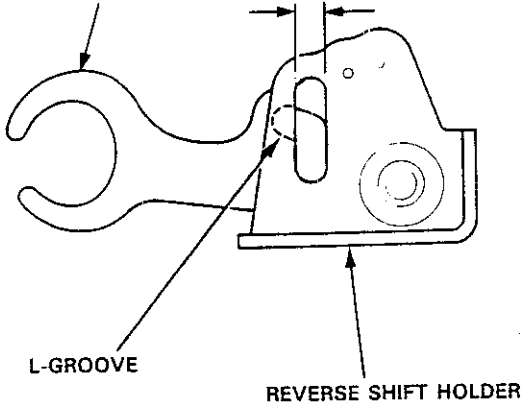

L-GROOVE

REVERSE SHIFT HOLDER

If the width of the groove exceeds the standard, replace the reverse shift holder with a new one.  
If the width of the groove is within the standard, replace the 5th/reverse shift piece with a new one.

- 3 Measure the clearance between the reverse idler gear and reverse shift fork

**Standard:** 0.5–1.1 mm (0.020–0.043 in)  
**Service Limit:** 1.8 mm (0.071 in)

REVERSE IDLER GEAR

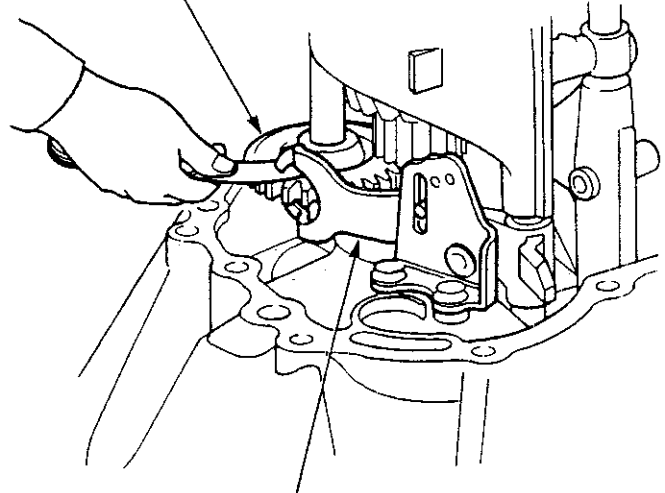

REVERSE SHIFT FORK

4. If the clearance exceeds the service limit, measure the width of the reverse shift fork

**Standard:** 12.7–13.0 mm (0.500–0.512 in)

REVERSE SHIFT HOLDER

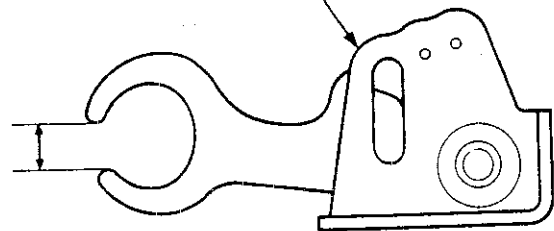

If the width exceeds the standard, replace the reverse shift holder with a new one.  
If the width is within the standard, replace the reverse idler gear with a new one.

# Mainshaft, Countershaft, Shift Fork

## Reverse Idler Gear

### Removal

- 1 Remove the reverse shift holder

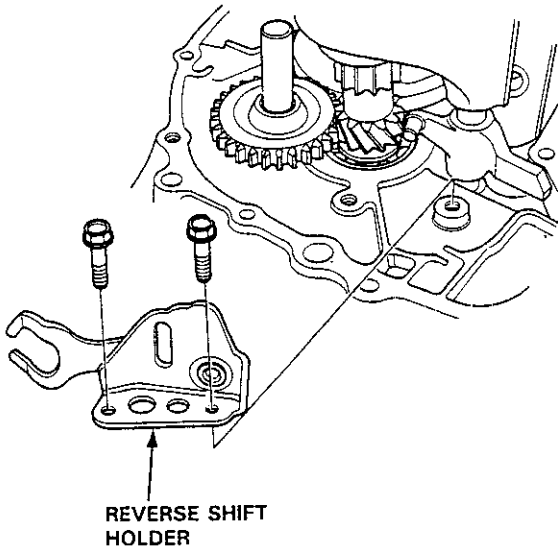

- 2 Remove the reverse idler gear shaft and gear

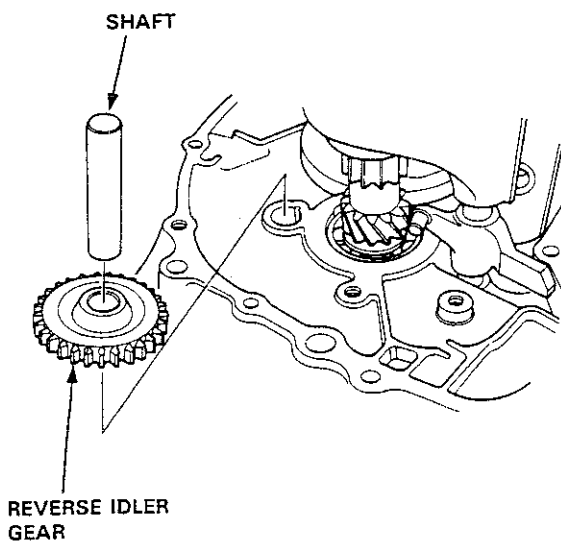

### Disassembly

1. Remove the interlock guide bolt from under the clutch housing
2. Remove the shift arm B attaching bolt.

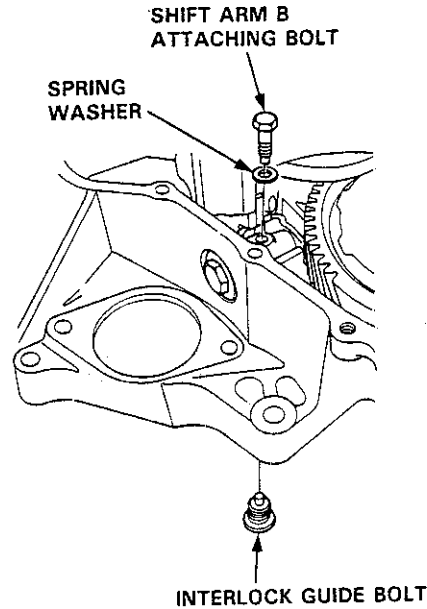

- 3 Remove the mainshaft and countershaft assemblies with the shift fork from the clutch housing

NOTE: Before removing the mainshaft and countershaft assemblies, tape the mainshaft spline to protect it

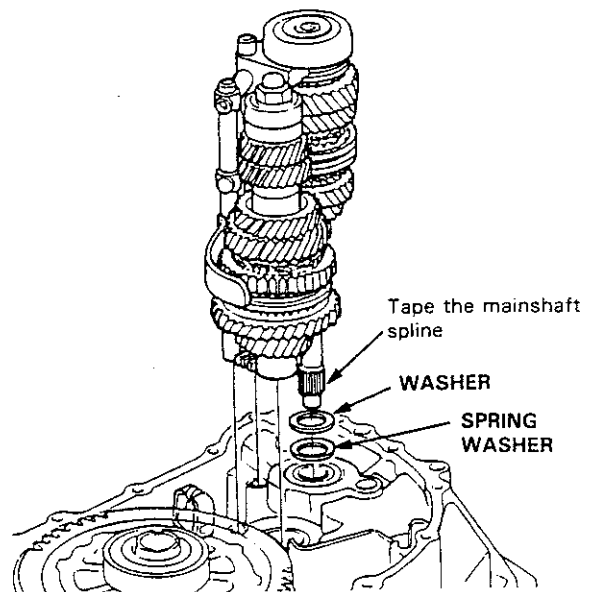



# Mainshaft Assembly

## Index

NOTE: The 3rd/4th and 5th synchro hubs are installed with a press

 Prior to reassembling, clean all the parts in solvent, dry them and apply lubricant to any contact surfaces. The 3rd/4th and 5th synchro hubs, however, should be installed with a press before lubricating them.

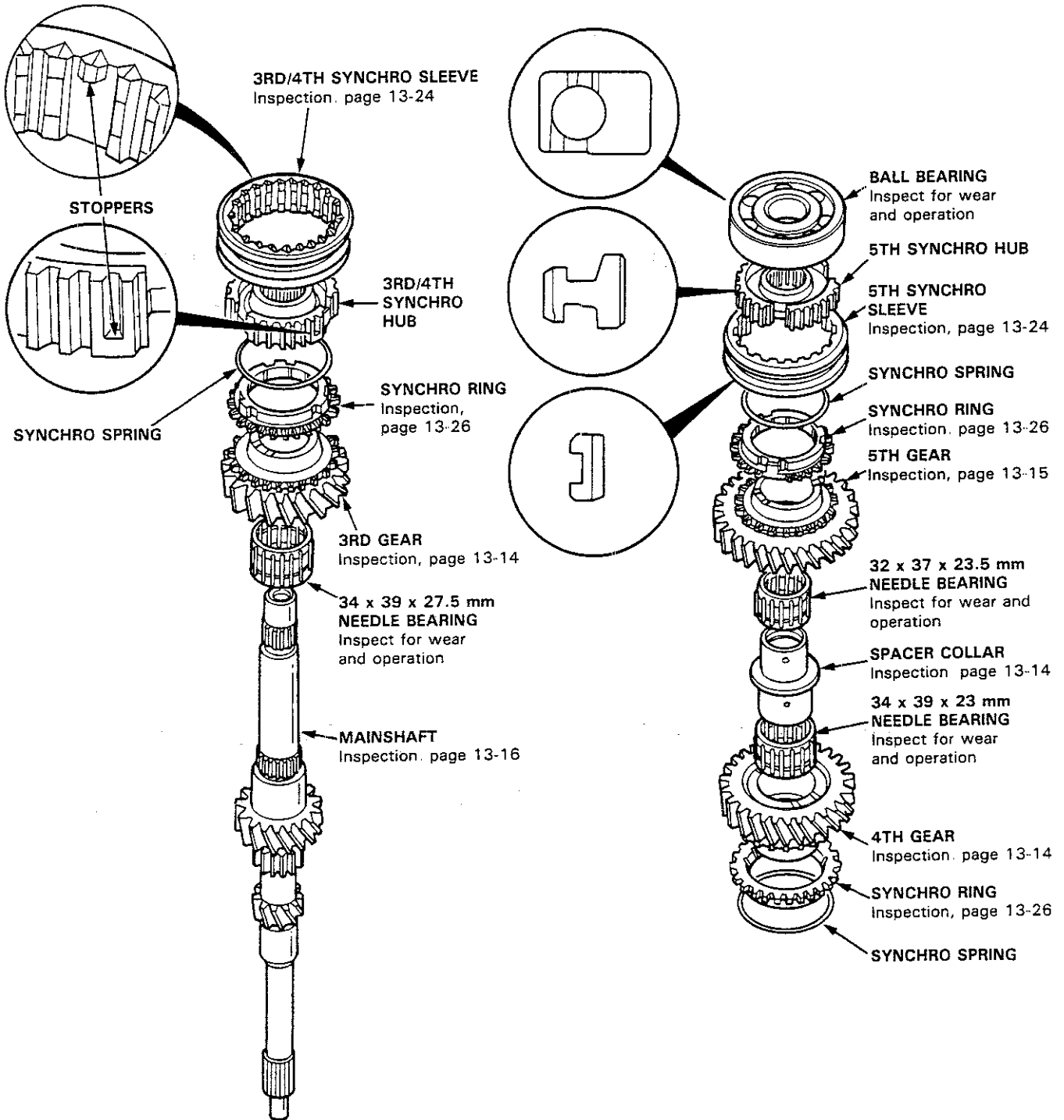

# Mainshaft Assembly

## Clearance Inspection

NOTE: If replacement is required, always replace the synchro sleeve and hub as a set.

1. Measure the clearance between 2nd and 3rd gears.

Standard: 0.06–0.21 mm (0.002–0.008 in)  
 Service Limit: 0.33 mm (0.013 in)

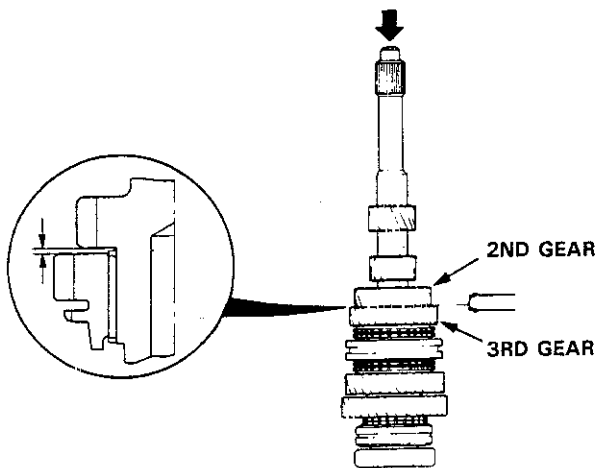

2. If the clearance exceeds the service limit, measure the thickness of 3rd gear

Standard: 30.22–30.27 mm  
 (1.190–1.192 in)  
 Service Limit: 30.15 mm (1.187 in)

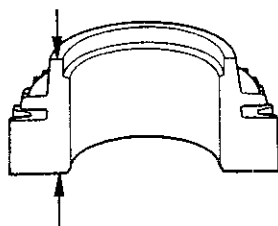

If the thickness of 3rd gear is less than the service limit, replace 3rd gear with a new one  
 If the thickness of 3rd gear is within the service limit replace the 3rd/4th synchro hub with a new one.

3. Measure the clearance between 4th gear and the spacer collar.

Standard: 0.06–0.19 mm (0.002–0.007 in)  
 Service Limit: 0.31 mm (0.012 in)

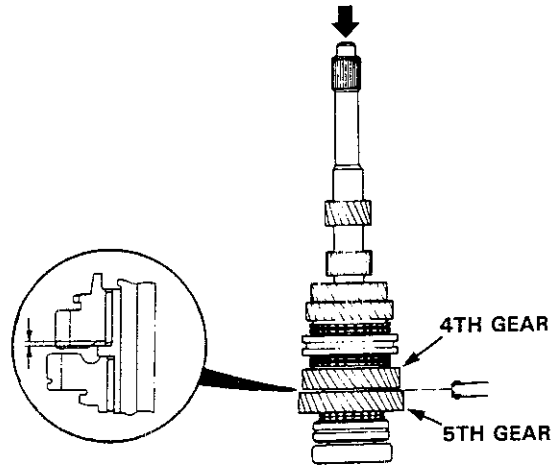

4. If the clearance exceeds the service limit, measure distance  $\textcircled{A}$  on the spacer collar

Standard: 22.83–22.86 mm  
 (0.899–0.900 in)  
 Service Limit: 22.81 mm (0.898 in)

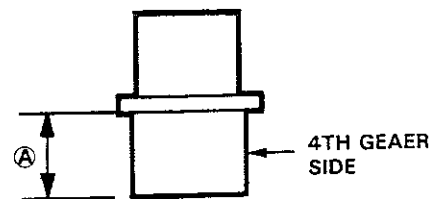

5. If distance  $\textcircled{A}$  is less than the service limit, replace the spacer collar with a new one.  
 If distance  $\textcircled{A}$  is within the service limit, measure the thickness of 4th gear.

Standard: 30.12–30.17 mm  
 (1.186–1.188 in)  
 Service limit: 30.05 mm (1.183 in)

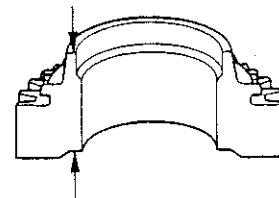

If the thickness of 4th gear is less than the service limit, replace 4th gear with a new one  
 If the thickness of 4th gear is within the service limit, replace the 3rd/4th synchro hub with a new one.





6. Measure the clearance between the spacer collar and 5th gear.

**Standard:** 0.06–0.19 mm (0.002–0.007 in)  
**Service limit:** 0.31 mm (0.012 in)

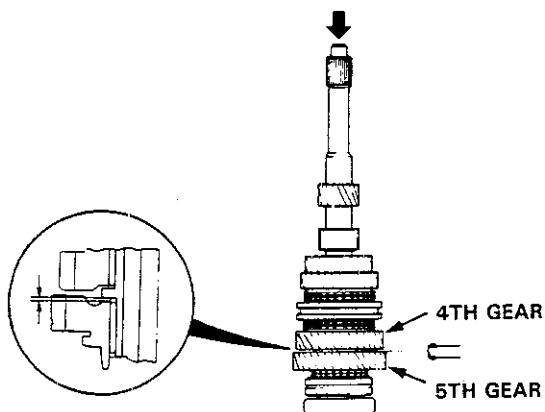

7. If the clearance exceeds the service limit, measure distance (B) on the spacer collar

**Standard:** 23.53–23.56 mm  
 (0.926–0.928 in)  
**Service Limit:** 23.51 mm (0.926 in)

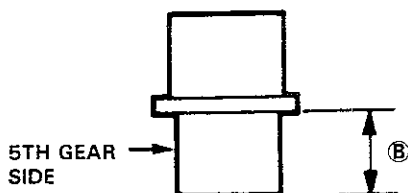

8. If distance (B) is less than service limit, replace the spacer collar with a new one.  
 If distance (B) is within the service limit, measure thickness of 5th gear.

**Standard:** 28.42–28.47 mm  
 (1.119–1.121 in)  
**Service Limit:** 28.35 mm (1.116 in)

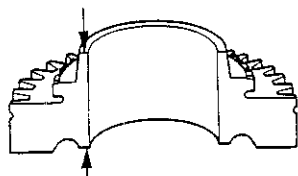

If the thickness of 5th gear is less than the service limit, replace 5th gear with a new one.  
 If the thickness of 5th gear is within the service limit, replace the 5th synchro hub with a new one.

## Disassembly

1. Remove the ball bearing using a bearing puller as shown.

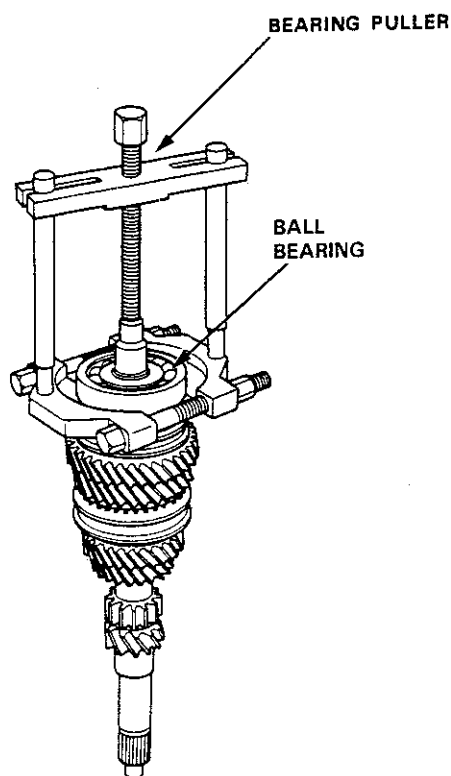

**CAUTION:** Remove the synchro hubs using a press and steel blocks as shown. Use of a jaw-type puller can cause damage to the gear teeth

2. Support 4th gear on steel blocks as shown and press the shaft out of the 5th synchro hub.

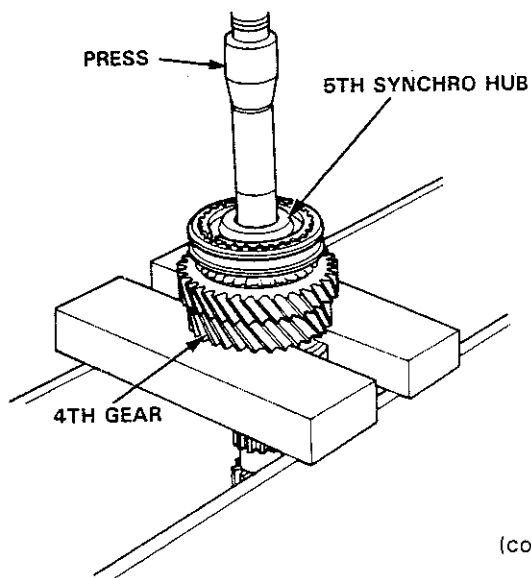

(cont'd)

# Mainshaft Assembly

## Disassembly (cont'd)

3. In the same manner as above, support the 3rd gear on steel blocks and press the shaft out of the 3rd/4th synchro hub.

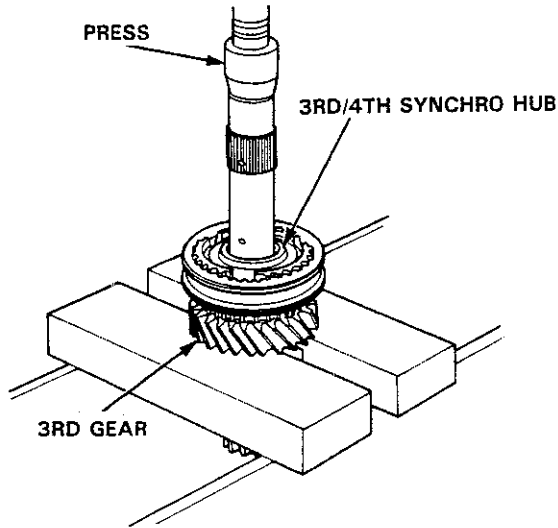

## Inspection

1. Inspect the gear surface and bearing surface for wear and damage, then measure the mainshaft at points A, B, C, and D.

<b>Standard:</b>	<b>A:</b> 21.987–22.000 mm (0.8656–0.8661 in)
	<b>B:</b> 26.980–26.993 mm (1.0622–1.0627 in)
	<b>C:</b> 33.984–34.000 mm (1.3380–1.3386 in)
	<b>D:</b> 25.977–25.990 mm (1.0227–1.0232 in)
<b>Service Limit:</b>	<b>A:</b> 21.93 mm (0.8634 in)
	<b>B:</b> 26.93 mm (1.0602 in)
	<b>C:</b> 33.93 mm (1.3358 in)
	<b>D:</b> 25.92 mm (1.0205 in)

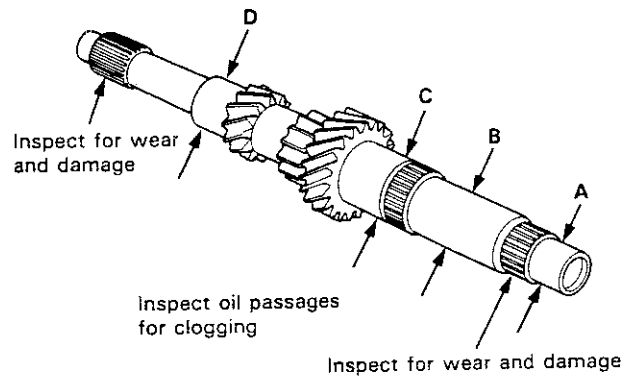

If any part of the mainshaft is less than the service limit, replace it with a new one

2. Inspect for runout.

<b>Standard:</b>	0.02 mm (0.001 in) min.
<b>Service Limit:</b>	0.05 mm (0.002 in)

NOTE: Support the mainshaft at both ends as shown

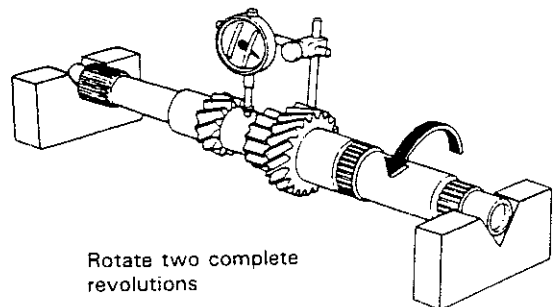

If the runout exceeds the service limit, replace the mainshaft with a new one.



## Reassembly

**CAUTION:** When installing the 3rd/4th and 5th synchro hubs, support the shaft on the steel blocks and install synchro hubs using a press.

NOTE: To assemble, see page 13-13.

1. Support 2nd gear on steel blocks as shown, then install the 3rd/4th synchro hub using a press.

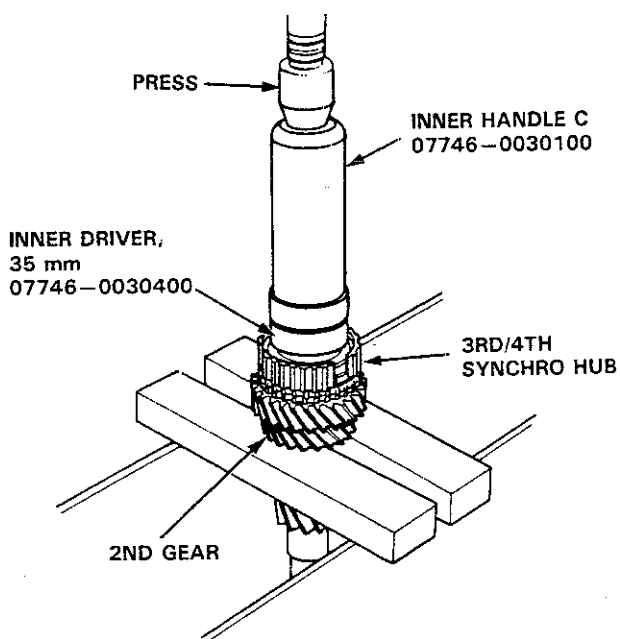

2. Install the 3rd/4th synchro sleeve by align the stoppers of the 3rd/4th synchro sleeve and hub.

NOTE: After installing, inspect the operation of the 3rd/4th synchro hub set

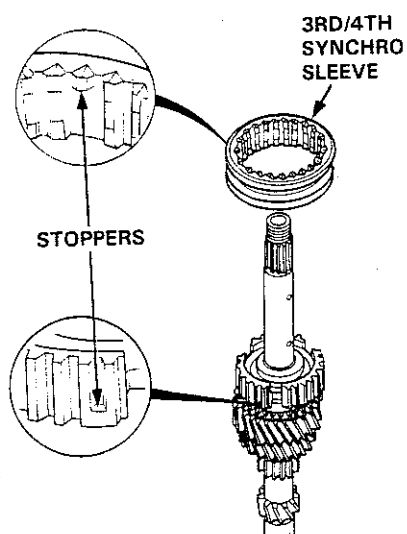

3. Install the 5th synchro hub using a press as shown.

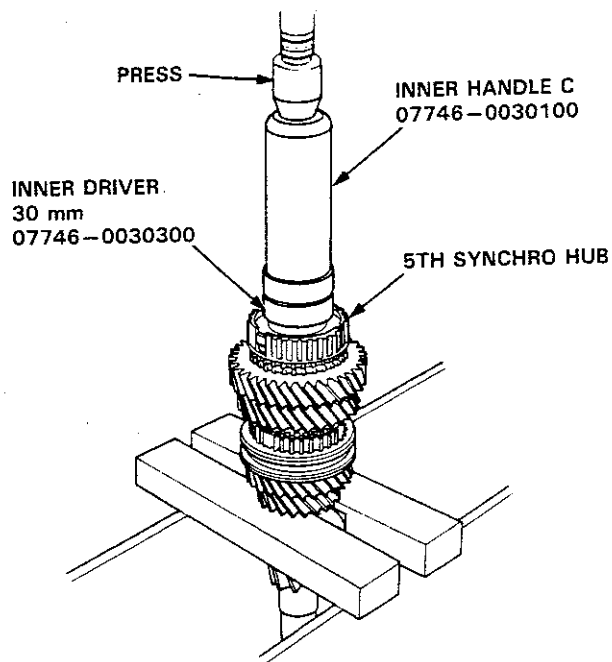

4. Install the ball bearing using a press as shown

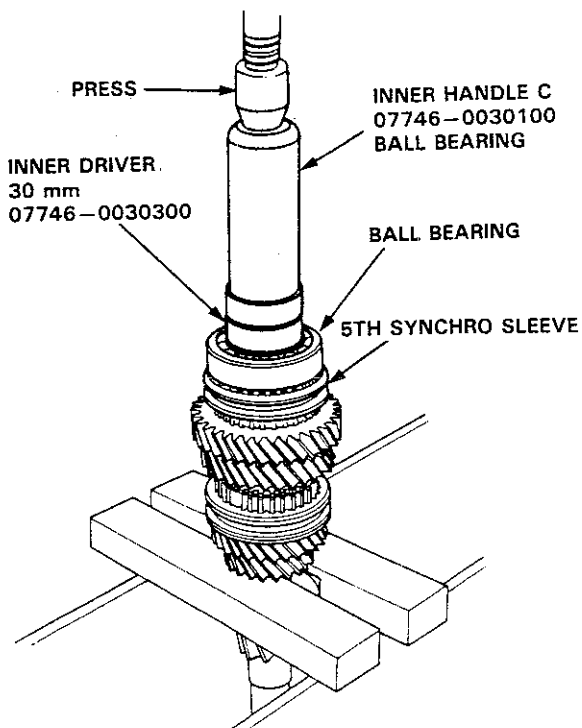

# Countershaft Assembly

## Index

NOTE: The 3rd, 4th, and 5th gears are installed with a press.

 Prior to reassembling, clean all the parts in solvent, dry them and apply lubricant to any contact surfaces. The 3rd, 4th, and 5th gears, however, should be installed with a press before lubricating them.

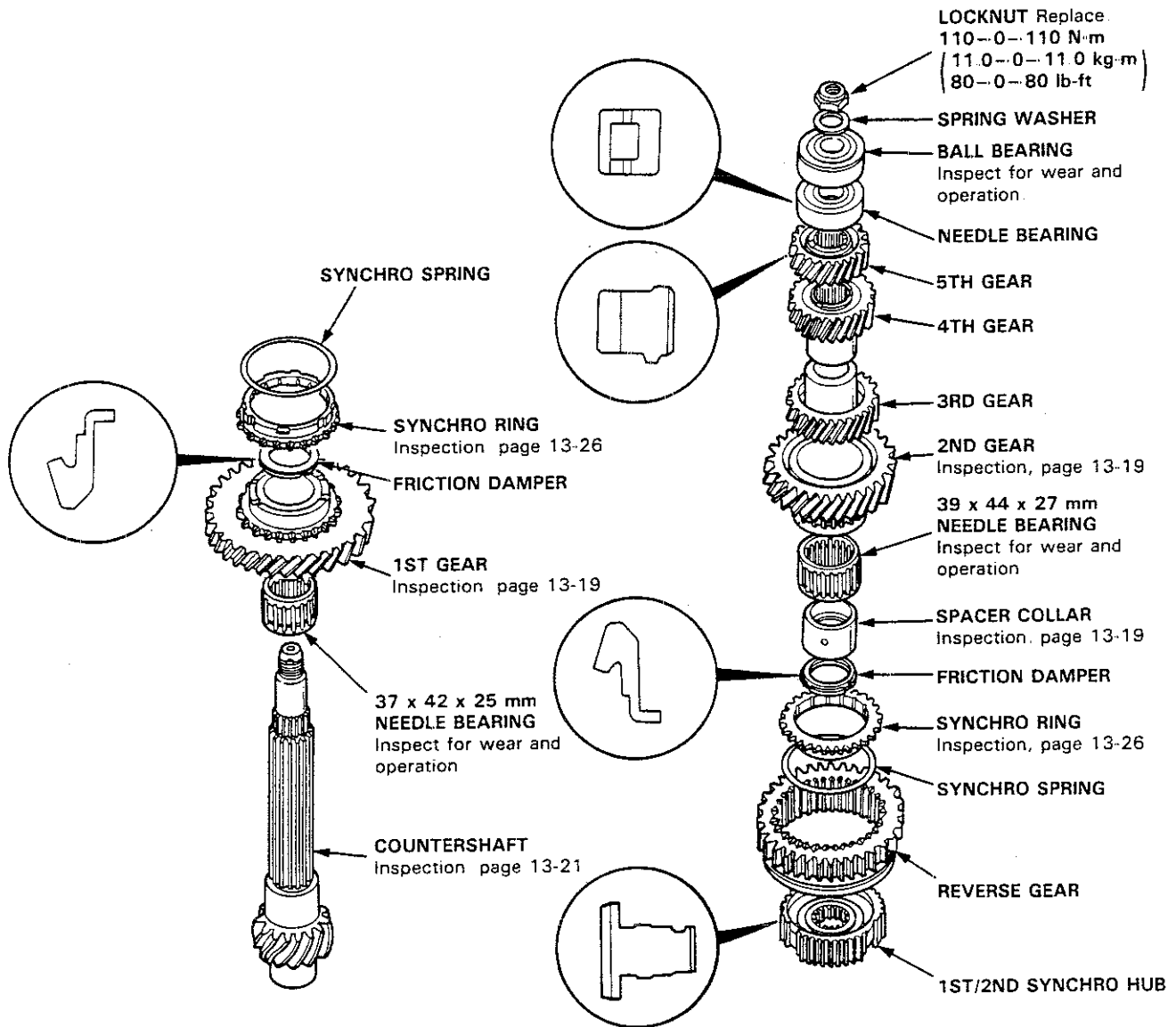



## Clearance Inspection

**NOTE:** If replacement is required, always replace the synchro sleeve and hub as a set.

- 1 Measure the clearance between the countershaft and 1st gear.

**Standard:** 0.03–0.10 mm (0.001–0.004 in)  
**Service Limit:** 0.22 mm (0.009 in)

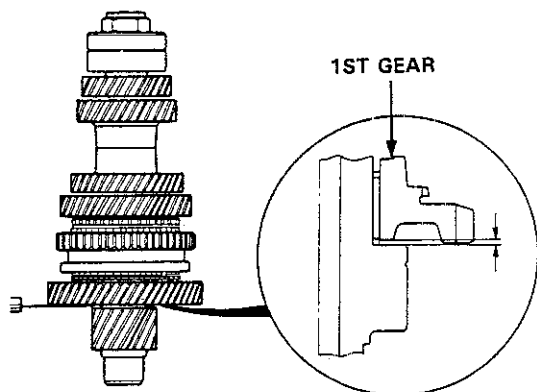

2. If the clearance exceeds the service limit, measure the thickness of 1st gear

**Standard:** 30.41–30.44 mm  
(1.197–1.198 in)  
**Service Limit:** 30.36 mm (1.195 in)

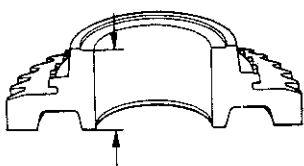

If the thickness of 1st gear is less than the service limit, replace 1st gear with a new one  
If the thickness of 1st gear is within the service limit, replace the 1st/2nd synchro hub with a new one

3. Measure the clearance between 2nd and 3rd gears.

**Standard:** 0.03–0.11 mm (0.001–0.004 in)  
**Service Limit:** 0.23 mm (0.009 in)

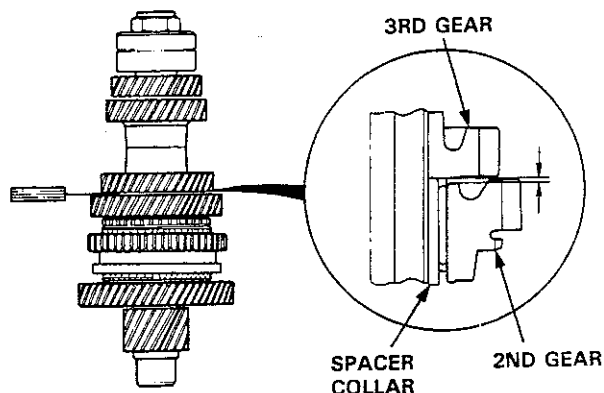

4. If the clearance exceeds the service limit, measure the thickness of the spacer collar

**Standard:** 32.03–32.06 mm  
(1.261–1.262 in)  
**Service Limit:** 32.01 mm (1.260 in)

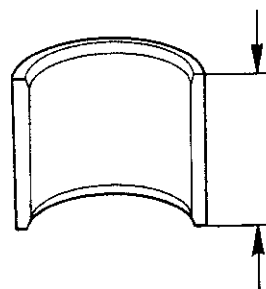

5. If the thickness is less than the service limit, replace the spacer collar with a new one.  
If the thickness is within the service limit, measure the thickness of 2nd gear

**Standard:** 31.92–31.97 mm  
(1.257–1.259 in)  
**Service Limit:** 31.85 mm (1.254 in)

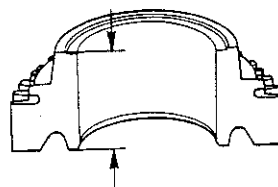

If the thickness of 2nd gear is less than the service limit, replace 2nd gear with a new one  
If the thickness of 2nd gear is within the service limit, replace the spacer collar with a new one

# Countershaft Assembly

## Disassembly

**CAUTION:** Remove the gears using a press and steel blocks as shown. Use of a jaw-type puller can damage the gear teeth.

1. Raise the locknut tab from the groove of the countershaft, then remove the locknut and the spring washer.

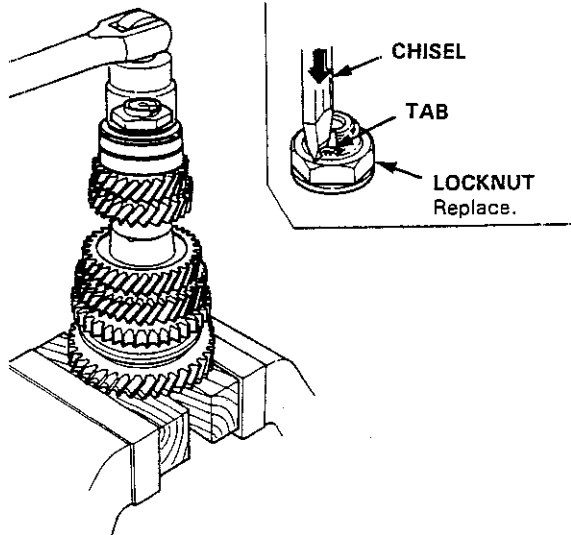

2. Remove the bearings using a bearing puller as shown

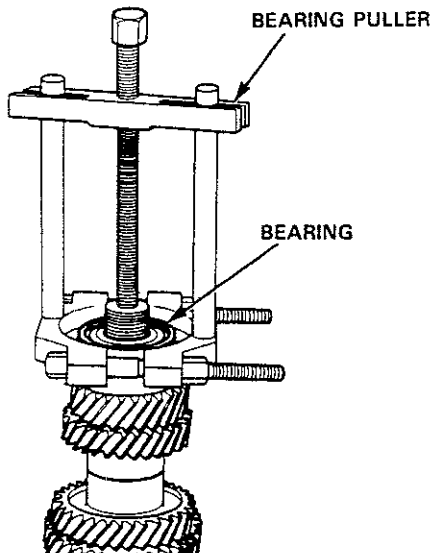

3. Support 4th gear on steel blocks as shown and press the countershaft out of 5th and 4th gears

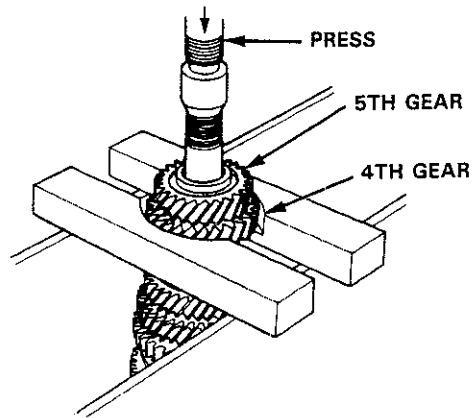

4. Support 1st gear on steel blocks as shown and press the countershaft out of 3rd gear.

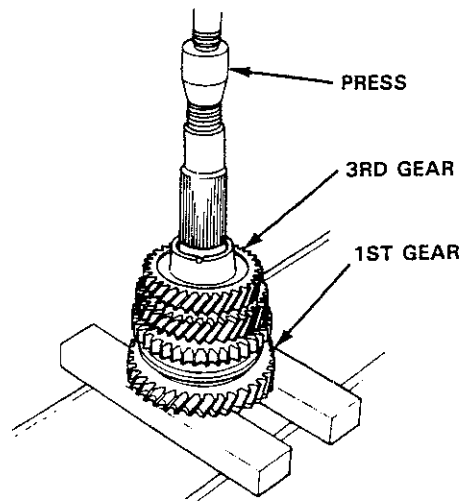



## Inspection

1. Inspect the gear surfaces and bearing surfaces for wear and damage, then measure the countershaft at points A, B, and C

**Standard:**

- A: 30.000–30.015 mm (1.1811–1.1817 in)
- B: 35.984–36.000 mm (1.4167–1.4173 in)
- C: 24.980–24.993 mm (0.9835–0.9840 in)

**Service Limit:**

- A: 29.95 mm (1.1791 in)
- B: 35.93 mm (1.4146 in)
- C: 24.93 mm (0.9815 in)

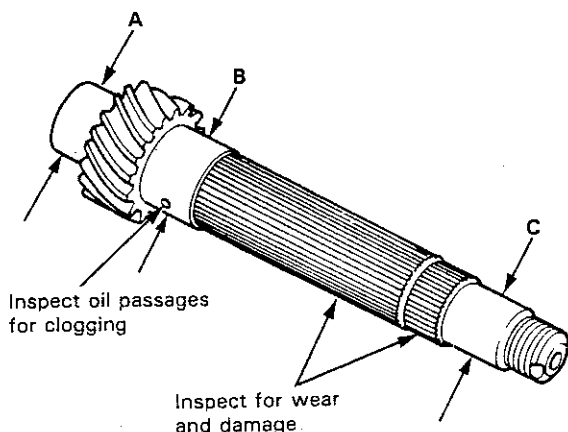

If any part of the countershaft is less than the service limit, replace it with a new one

2. Inspect for runout.

**Standard:** 0.02 mm (0.0008 in) min.  
**Service Limit:** 0.05 mm (0.0020 in)

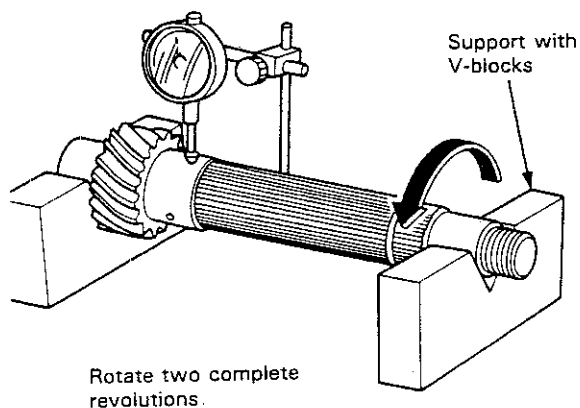

If the runout exceeds the service limit, replace the countershaft with a new one

## Reassembly

### CAUTION:

- Press the 3rd, 4th, and 5th gears on the countershaft without lubrication.
- When installing the 3rd, 4th, and 5th gears, support the shaft on steel blocks and install the gears using a press

NOTE: To assemble, see page 13-18.

1. Install the needle bearing on the countershaft.

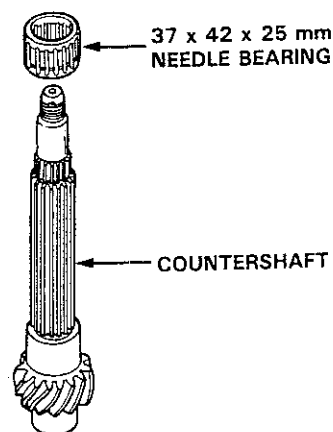

2. Assemble the parts below as shown

NOTE: Check that the finger of the friction damper are securely set in the grooves of the 1st/2nd synchro hub.

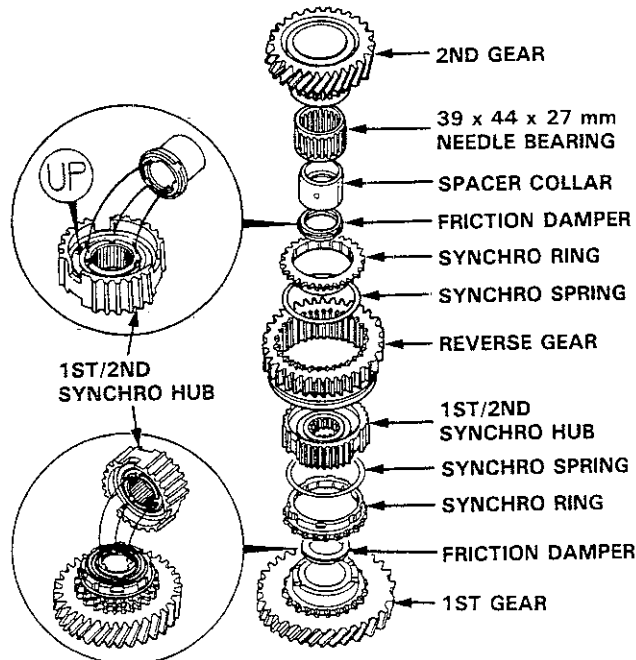

3. Place the parts assembled in step 2, then install the parts on the countershaft

(cont'd)

# Countershaft Assembly

## Reassembly (cont'd)

4. Support the countershaft on a steel block as shown and install 3rd gear using the special tools and a press.

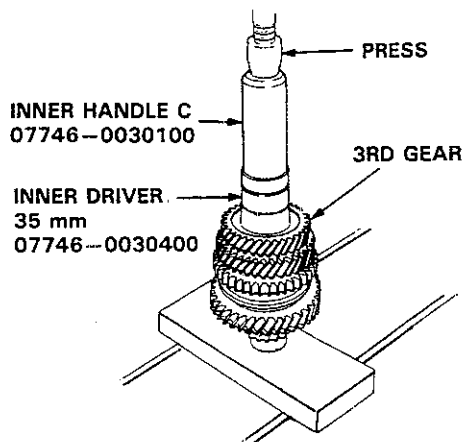

5. Install 4th gear using the special tools and a press as shown.

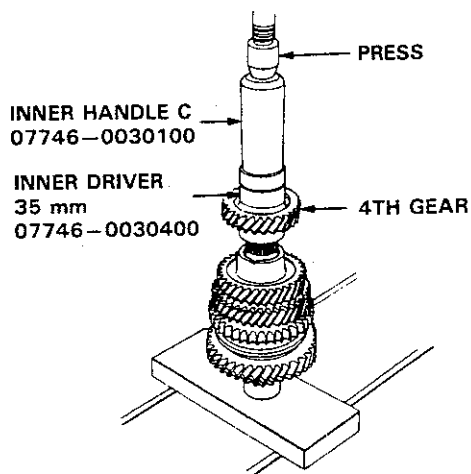

6. Install 5th gear using the special tools and a press as shown.

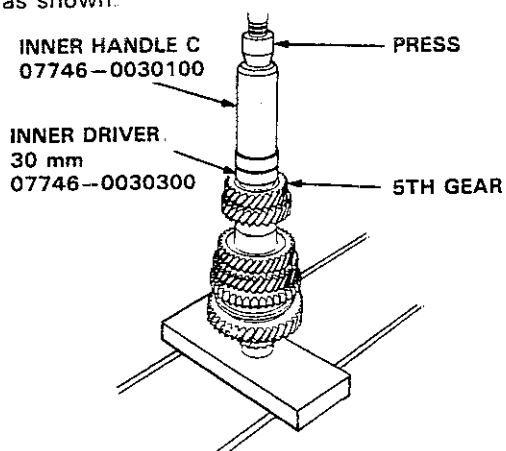

7. Install the bearings using the special tools and a press as shown.

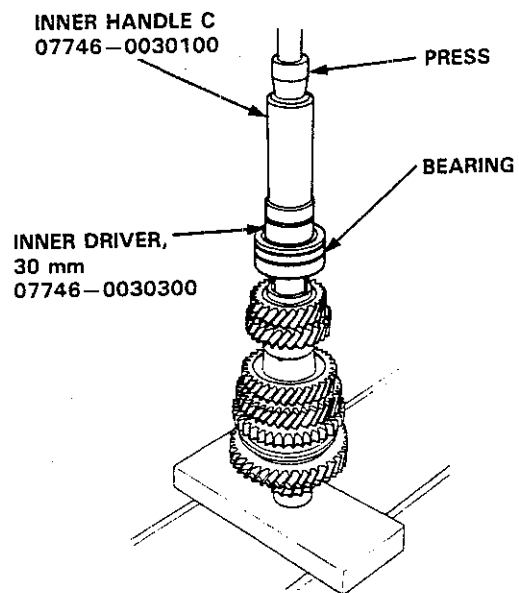

8. Install the spring washer, tighten the locknut, then stake the locknut tab into the groove.

### LOCKNUT

110-0-110 N·m

(11.0-0-11.0 kg·m, 80-0-80 lb-ft)

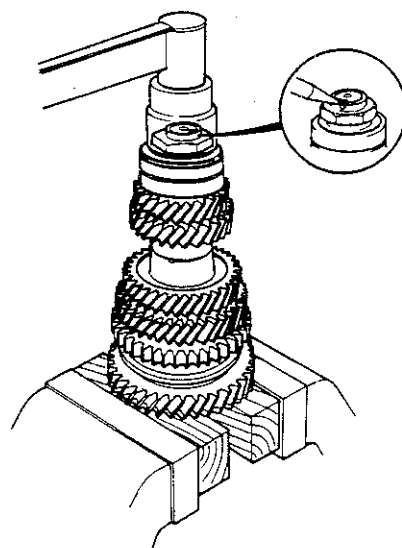





# Shift Fork Assembly

## Disassembly/Reassembly

**NOTE:**

- When disassembling, pay attention to the steel balls as the springs may force them out.
- When assembling, install the shift fork shaft with its detents facing the hole where the balls are inserted.
- The steel balls are all of the same size

 Prior to reassembling, clean all the parts in solvent, dry them and apply lubricant to any contact parts

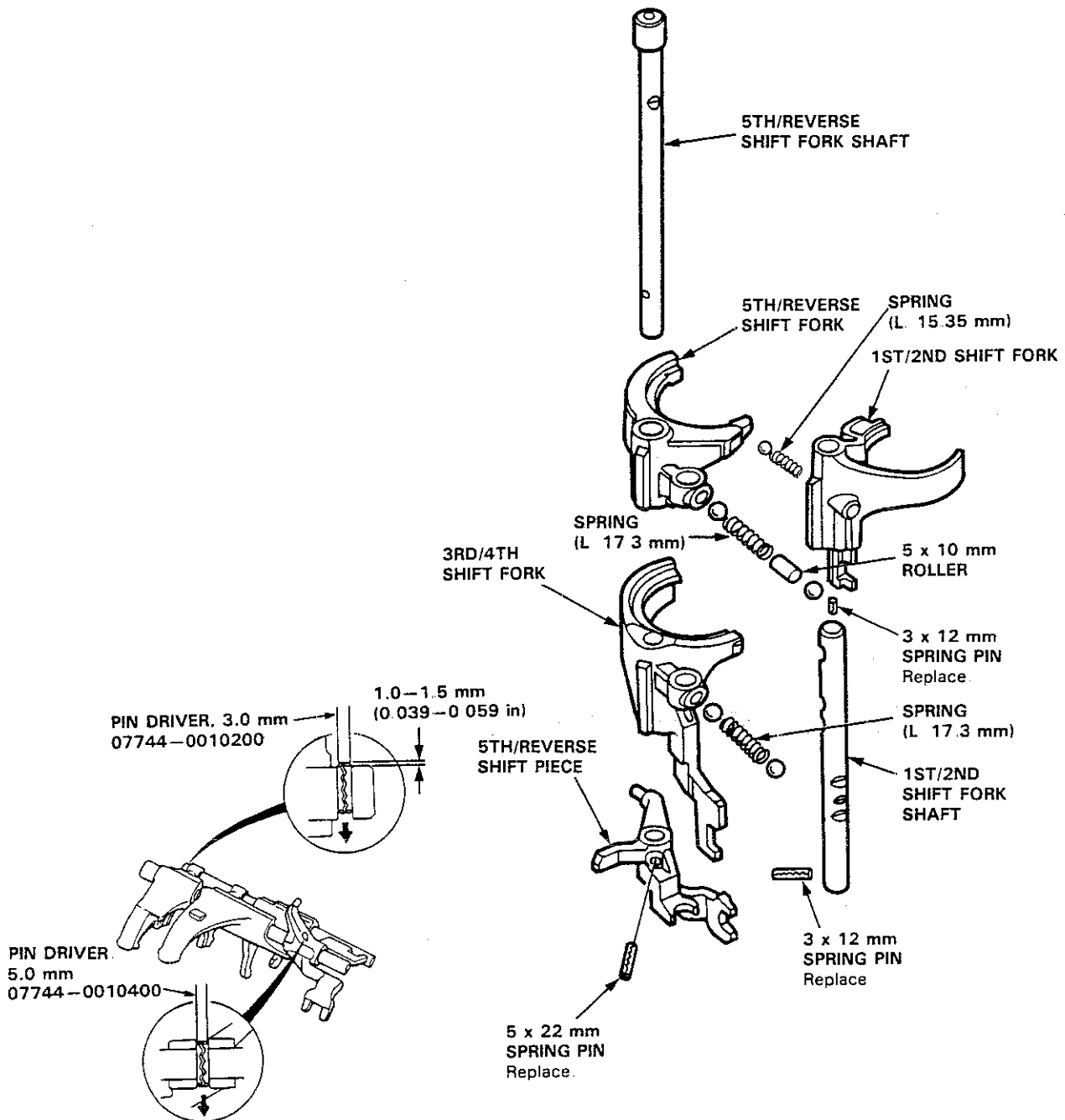

# Shift Fork Assembly

## Clearance Inspection

1. Measure the clearance between each shift fork and its matching synchro sleeve.

Standard: 0.25–0.45 mm (0.010–0.018 in)  
Service Limit: 0.8 mm (0.032 in)

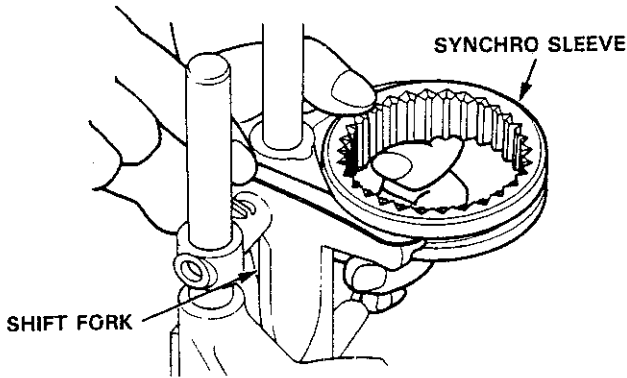

2. If the clearance exceeds the service limit, measure the thickness of the shift fork fingers.

Standard: 6.4–6.5 mm (0.252–0.255 in)

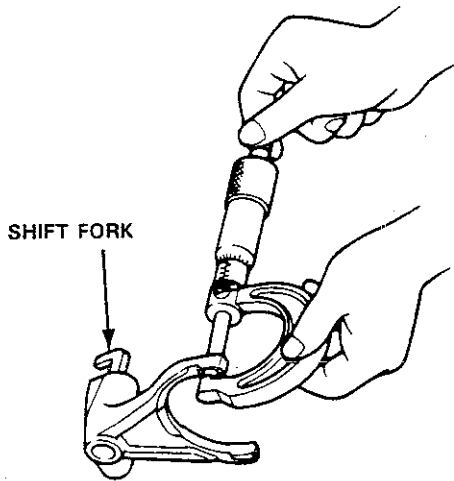

3. If the thickness of the shift fork fingers is less than the standard, replace the shift fork with a new one. If the thickness of the shift fork fingers is within the standard, replace the synchro sleeve with a new one.

NOTE: The synchro sleeve and synchro hub should be replaced as a set.

4. Measure the clearance between the 3rd/4th shift fork and shift arm B.

Standard: 0.2–0.5 mm (0.008–0.020 in)  
Service Limit: 0.62 mm (0.024 in)

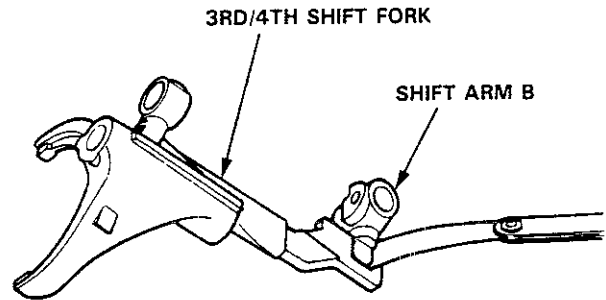

5. If the clearance exceeds the service limit, measure the width of the shift arm B.

Standard: 12.9–13.0 mm (0.508–0.512 in)  
Service Limit: 12.78 mm (0.503 in)

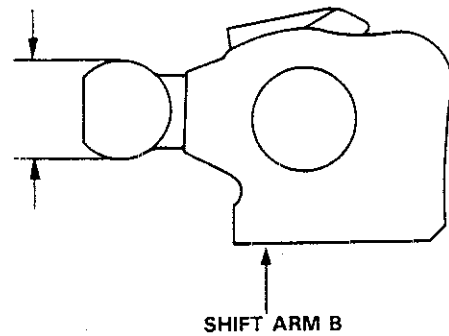

6. If the width of the shift arm B is less than the service limit, replace the shift arm B with a new one. If the width of the shift arm is within the service limit, replace the 3rd/4th shift fork with a new one.



# Synchro Sleeve, Synchro Hub

## Inspection

1. Inspect gear teeth on all synchro hubs and sleeves for rounded off corners, which indicate wear
2. Install each hub in its mating sleeve and check for freedom of movement.

NOTE: If replacement is required, always replace the synchro sleeve and hub as a set.

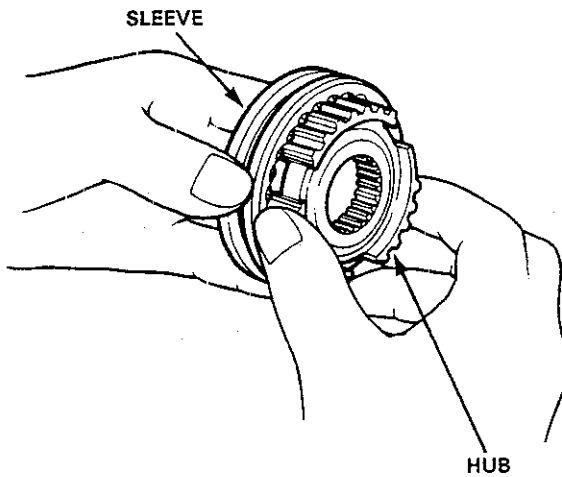

## Installation

Each synchro sleeve has three sets of longer teeth (120 degrees apart) that must be matched with the three sets of deeper grooves in the hub when assembled.

NOTE: Installing the synchro sleeve with its longer teeth in the 1st/2nd synchro hub slots will damage the spring ring.

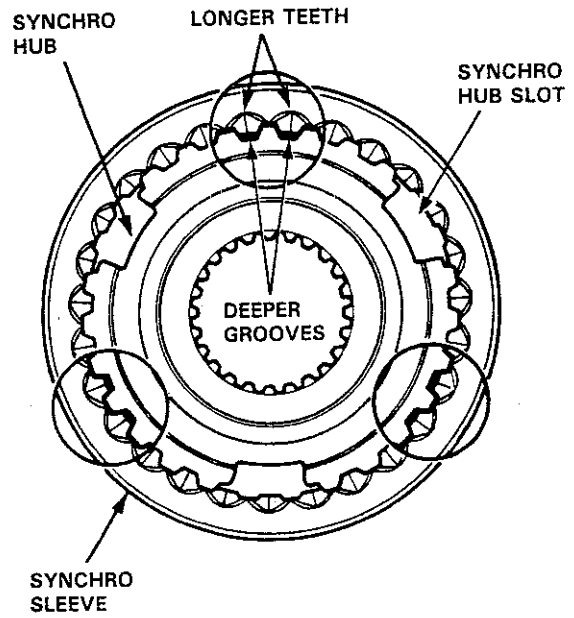

# Synchro Ring, Gear

## Inspection

1. Inspect the inside of the synchro ring for wear.
2. Inspect the synchro sleeve teeth and matching teeth on the synchro ring for wear (rounded off).

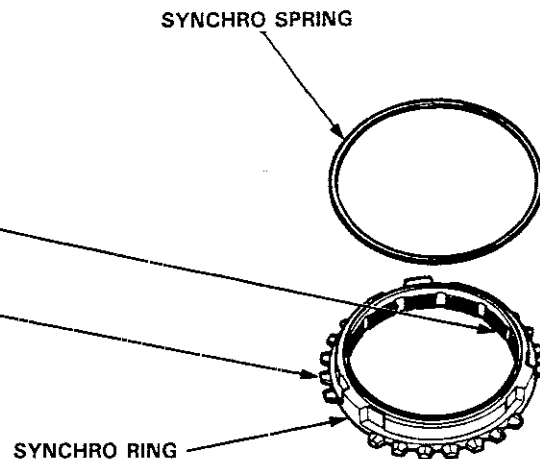

3. Inspect the synchro sleeve teeth and matching teeth on the gear for wear (rounded off).

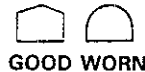

4. Inspect the gear hub thrust surface for wear.
5. Inspect the cone surface for wear and roughness.
6. Inspect the teeth on all gears for uneven wear, scoring, galling, and cracks.
7. Coat the cone surface of the gear with oil and place the synchro ring on the matching gear. Rotate the ring, making sure that it does not slip.

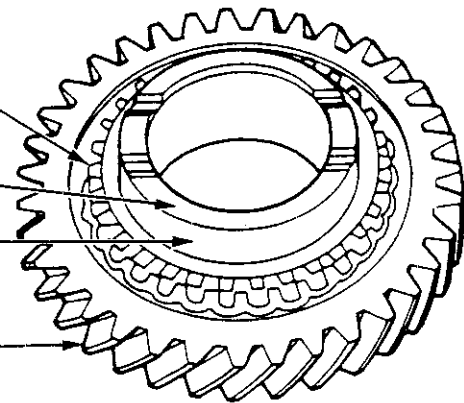

Measure the clearance between the ring and gear all the way around

NOTE: Hold the ring against the gear evenly while measuring the clearance

### Ring-to-Gear Clearance

Standard: 0.73–1.18 mm  
(0.029–0.046 in)

Service Limit: 0.4 mm (0.016 in)

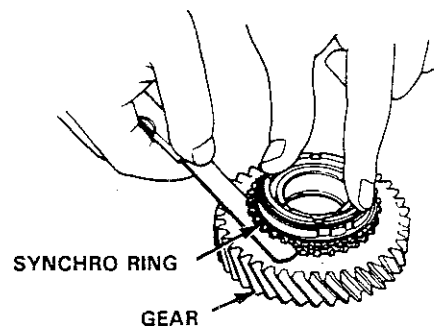



# Shift Rod

## Removal

NOTE: The steel balls are all of the same size

1. Remove the differential assembly
2. Remove the 28 mm plug bolt and 1st/2nd select spring
3. Remove the shift arm C attaching bolt
4. Remove the shift arm shaft.

NOTE: Be careful not to lose the steel ball.

5. Remove the steel ball, spring, and collar.

6. Remove shift arms C and B, and the interlock, then remove the reverse select spring and retainer
7. Remove the shift arm A attaching bolt, the set ball spring bolt, set spring, and steel ball
8. Remove the shift rod, then remove the shift arm A.
9. Remove the reverse lock cam
10. Remove the magnet.

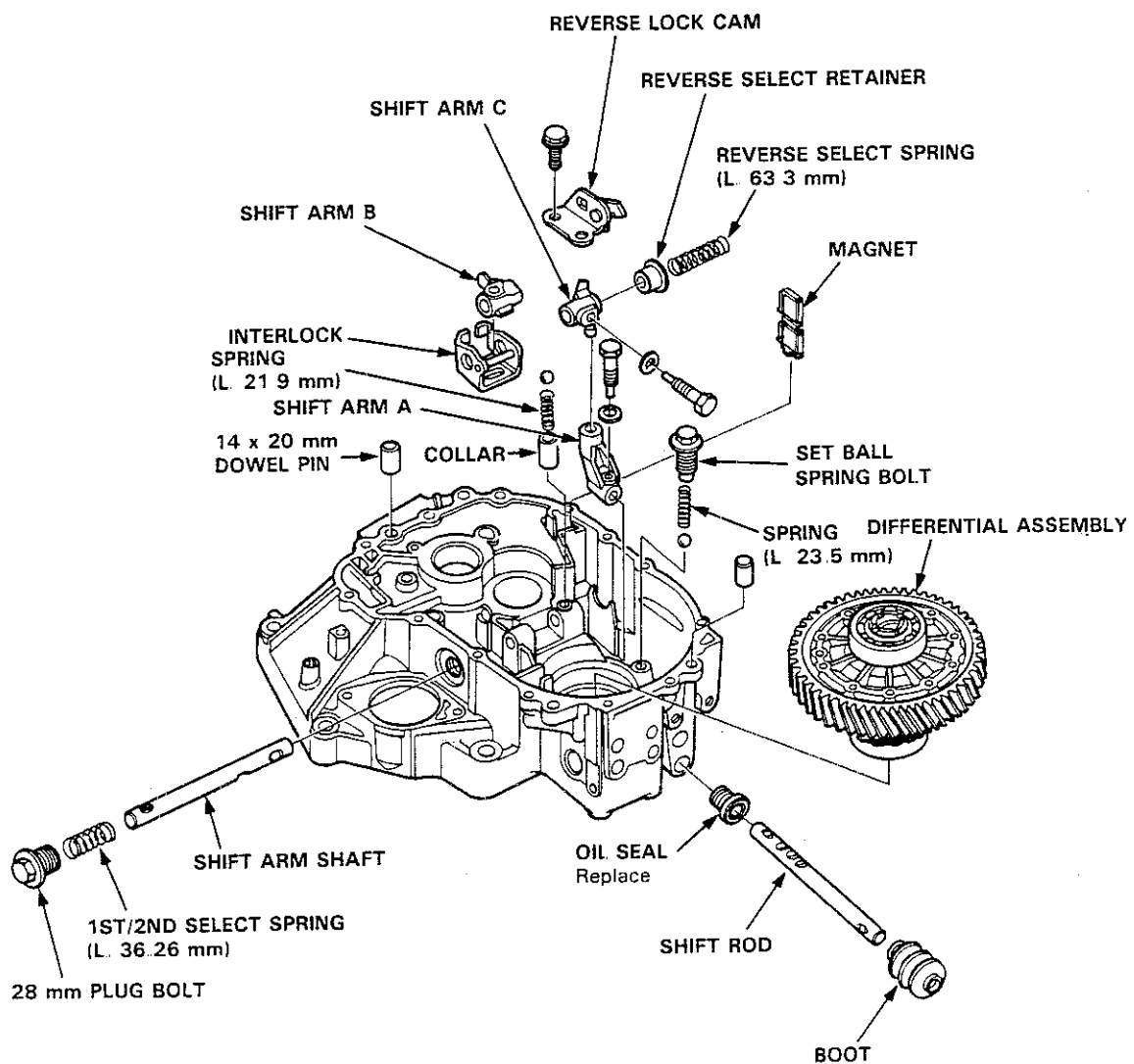

# Clutch Housing Bearing

## Replacement

### Mainshaft

- 1 Remove the ball bearing using the special tools

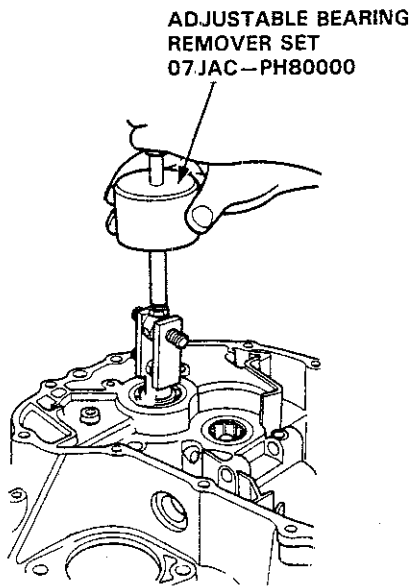

- 2 Remove the oil seal from the clutch housing.

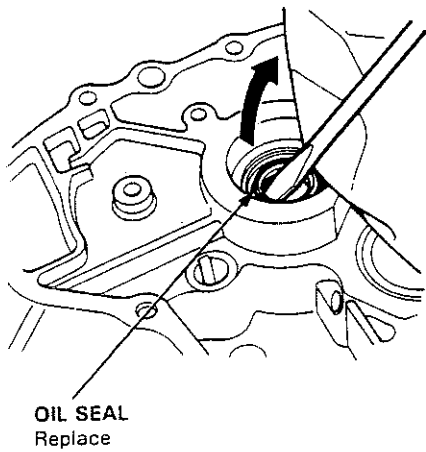

- 3 Drive the new oil seal into the clutch housing using the special tools.

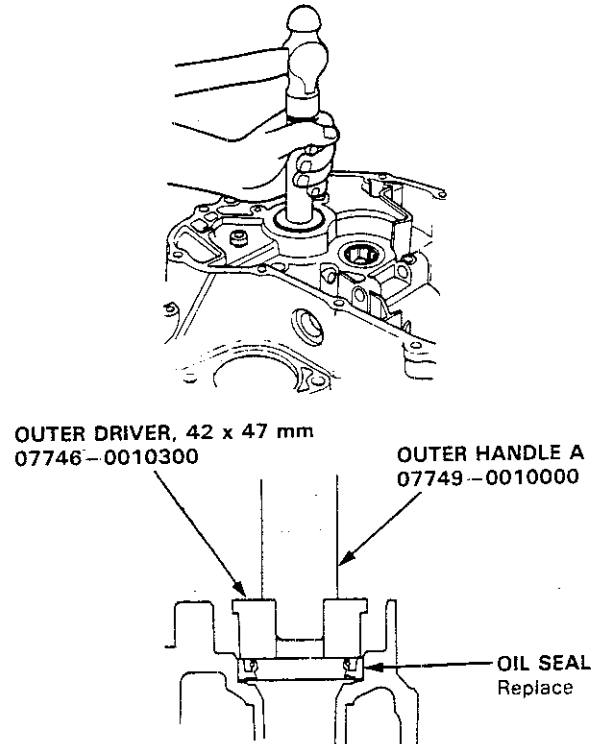

- 4 Drive the ball bearing into the clutch housing using the special tools.

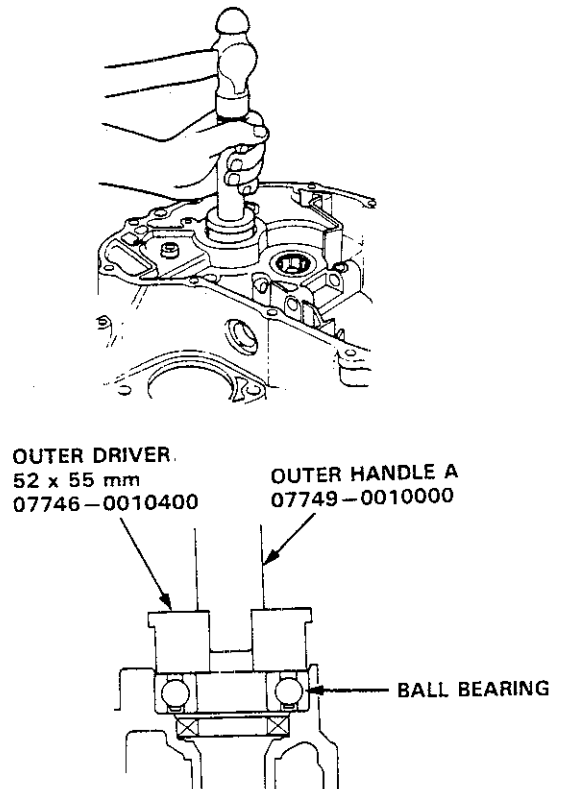



### Countershaft

- 1 Remove the needle bearing using the special tools, then remove the oil guide plate

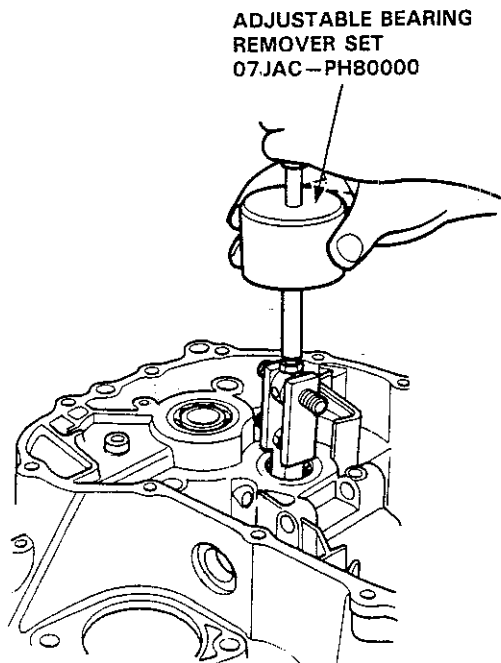

- 2 Install the oil guide plate, then drive the needle bearing into the clutch housing using the special tools

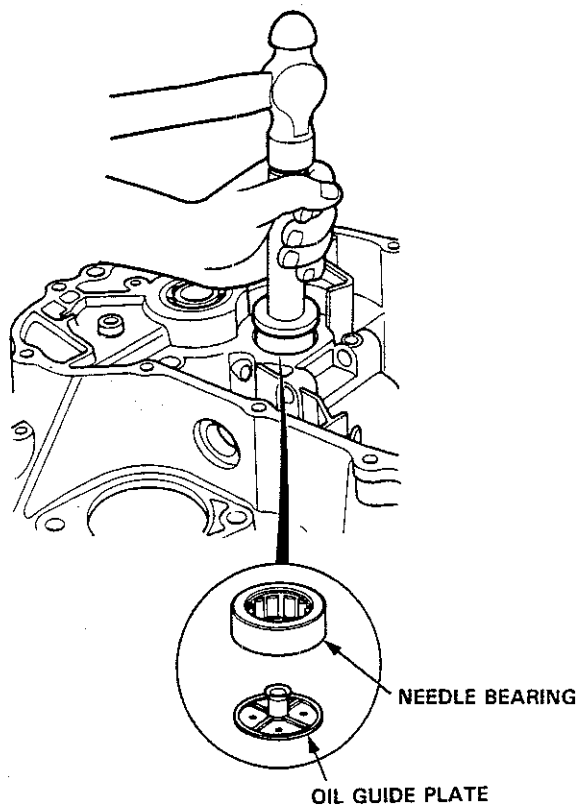

OUTER DRIVER.  
52 x 55 mm  
07746-0010400

OUTER HANDLE A  
07749-0010000

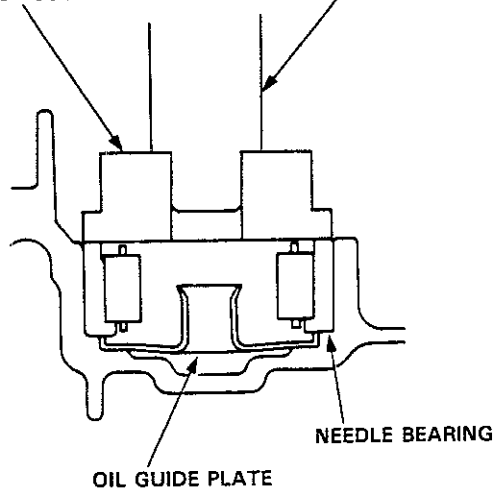

# Mainshaft Thrust Shim

## Adjustment

1. Remove the thrust shim and oil guide plate from the transmission housing.
2. Install the 3rd/4th synchro hub, spacer collar, 5th synchro hub, ball bearing, and thrust washer on the mainshaft. Install the assembly in the transmission housing.

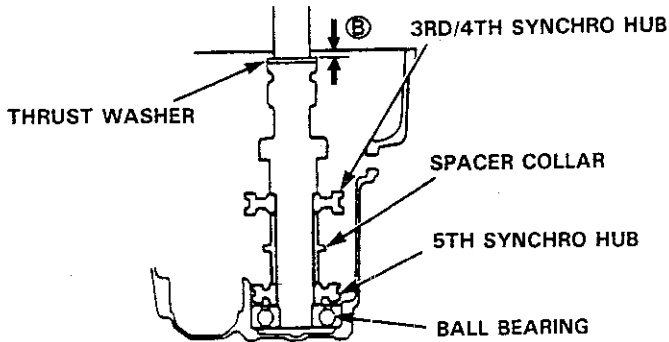

3. Measure the distance (B) between the end of the transmission housing and thrust washer.

### NOTE:

- Use a straight edge and feeler gauge
- Measure at three locations and average the readings

4. Measure the distance (C) between the surfaces of the clutch housing and bearing inner race.

### NOTE:

- Use a straight edge and feeler gauge.
- Measure at three locations and average the readings.

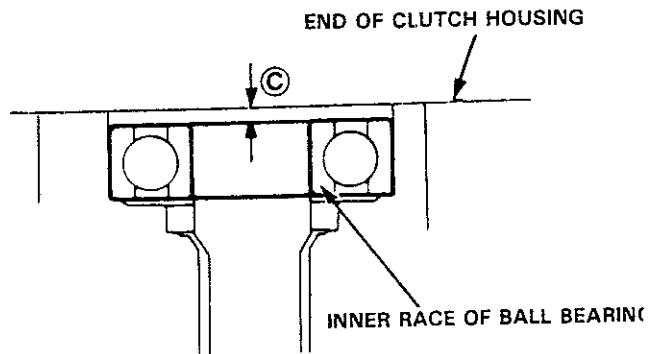

5. Select the proper shim on the basis of the following calculations:

NOTE: Do not use more than two shims

(Basis Formula)

$$(B) + (C) - 0.95 = \text{shim thickness}$$

### Example of calculation:

$$\begin{aligned} &\text{Distance (B) (2.00 mm) + Distance (C) (0.09 mm) =} \\ &2.09 \text{ mm subtract the spring washer height (0.95 mm)} \\ &= \text{the required thrust shim (1.14 mm)} \end{aligned}$$





### 70 mm Thrust Shim

	PART NUMBER	THICKNESS
A	23931-PL3-B00	0.60 mm (0.0236 in)
B	23932-PL3-B00	0.63 mm (0.0284 in)
C	23933-PL3-B00	0.66 mm (0.0260 in)
D	23934-PL3-B00	0.69 mm (0.0272 in)
E	23935-PL3-B00	0.72 mm (0.0283 in)
F	23936-PL3-B00	0.75 mm (0.0295 in)
G	23937-PL3-B00	0.78 mm (0.0307 in)
H	23938-PL3-B00	0.81 mm (0.0319 in)
I	23939-PL3-B00	0.84 mm (0.0331 in)
J	23940-PL3-B00	0.87 mm (0.0343 in)
K	23941-PL3-B00	0.90 mm (0.0354 in)
L	23942-PL3-B00	0.93 mm (0.0366 in)
M	23943-PL3-B00	0.96 mm (0.0378 in)
N	23944-PL3-B00	0.99 mm (0.0390 in)
O	23945-PL3-B00	1.02 mm (0.0402 in)
P	23946-PL3-B00	1.05 mm (0.0413 in)
Q	23947-PL3-B00	1.08 mm (0.0425 in)
R	23948-PL3-B00	1.11 mm (0.0437 in)
S	23949-PL3-B00	1.14 mm (0.0449 in)
T	23950-PL3-B00	1.17 mm (0.0461 in)
U	23951-PL3-B00	1.20 mm (0.0472 in)
V	23952-PL3-B00	1.23 mm (0.0484 in)
W	23953-PL3-B00	1.26 mm (0.0496 in)
X	23954-PL3-B00	1.29 mm (0.0508 in)
Y	23955-PL3-B00	1.32 mm (0.0520 in)
Z	23956-PL3-B00	1.35 mm (0.0531 in)
AA	23957-PL3-B00	1.38 mm (0.0543 in)
AB	23958-PL3-B00	1.41 mm (0.0555 in)
AC	23959-PL3-B00	1.44 mm (0.0567 in)
AD	23960-PL3-B00	1.47 mm (0.0579 in)
AE	23961-PL3-B00	1.50 mm (0.0591 in)
AF	23962-PL3-B00	1.53 mm (0.0602 in)
AG	23963-PL3-B00	1.56 mm (0.0614 in)
AH	23964-PL3-B00	1.59 mm (0.0626 in)
AI	23965-PL3-B00	1.62 mm (0.0638 in)
AJ	23966-PL3-B00	1.65 mm (0.0650 in)
AK	23967-PL3-B00	1.68 mm (0.0661 in)
AL	23968-PL3-B00	1.71 mm (0.0673 in)
AM	23969-PL3-B00	1.74 mm (0.0685 in)
AN	23970-PL3-B00	1.77 mm (0.0697 in)
AO	23971-PL3-B00	1.80 mm (0.0709 in)

6. Check the thrust clearance in the manner described below

**NOTE:**

- Clean the thrust washer, spring washer and shim thoroughly before installation.
- Install the thrust washer, spring washer and shim properly
  - a Install the shim selected in the transmission housing
  - b Install the thrust washer and spring washer in the mainshaft

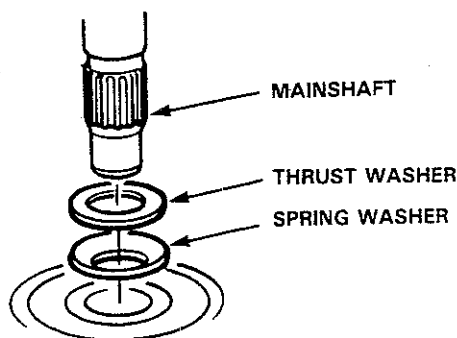

- c. Install the mainshaft in the clutch housing.
- d. Place the transmission housing over the mainshaft and onto the clutch housing
- e. Tighten the clutch and transmission housings with several 8 mm bolts.
- f. Tap the mainshaft with a plastic hammer.

7. Check the thrust clearance in the manner described below.

**CAUTION:** Measurement should be made at room temperature.

- a. Slide the mainshaft base and the collar over the mainshaft.

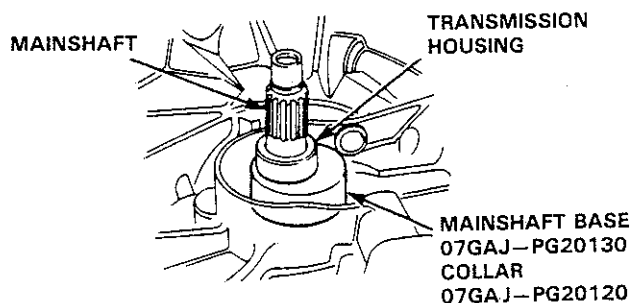

(cont'd)

# Mainshaft Thrust Shim

## Adjustment (cont'd)

- b. Attach the mainshaft holder to the mainshaft as follows:
- Back-out the mainshaft holder bolt and loosen the two hex bolts
  - Fit the holder over the mainshaft so its lip is towards the transmission.
  - Align the mainshaft holder's lip around the groove at the inside of the mainshaft splines, then tighten the hex bolts.

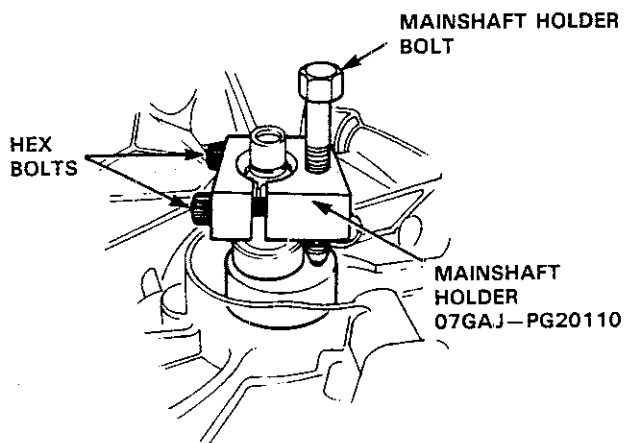

- c. Seat the mainshaft fully by tapping its end with a plastic hammer.
- d. Thread the mainshaft holder bolt in until it just contacts the wide surface of the mainshaft base.

- e. Zero a dial gauge on the end of the mainshaft.

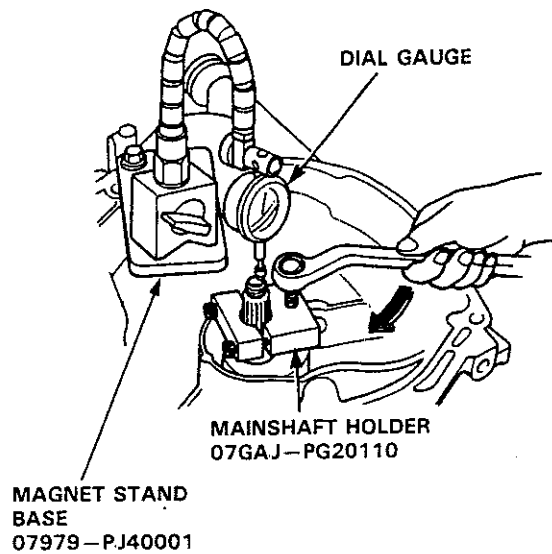

- f. Turn the mainshaft holder bolt clockwise; stop turning when the dial gauge has reached its maximum movement. The reading on the dial gauge is the amount of mainshaft end play.

**CAUTION:** Turning the shaft holder bolt more than 60 degrees after the needle of the dial gauge stops moving may damage the transmission.

- g. If the reading is within the standard, clearance is correct. It is not necessary to recheck the shim thickness.

**Standard:** 0.11–0.18 mm (0.004–0.007 in)



# Transmission

## Reassembly

NOTE: The steel balls are all of the same size.

1. Install the magnet and reverse lock cam
2. Set shift arm A on the clutch housing, then install the shift rod
3. Install the spring washer and shift arm A attaching bolt.
4. Install the steel ball, spring, and set ball spring bolt.
5. Install shift arm B in the interlock, then set it on the clutch housing
6. Insert shift arm shaft in the clutch housing
7. Install the collar, spring, and steel ball into the case. Compress the ball and insert the shift arm shaft.
8. Install shift arm C in shift arm A, then insert the shift arm shaft.
9. Install the reverse select retainer and reverse select spring onto shift arm shaft.
10. Install the differential assembly

\* 8 x 10 mm  
32 N·m (3.2 kg·m, 23 lb·ft)

6 x 1.0 mm  
15 N·m (1.5 kg·m, 11 lb·ft)

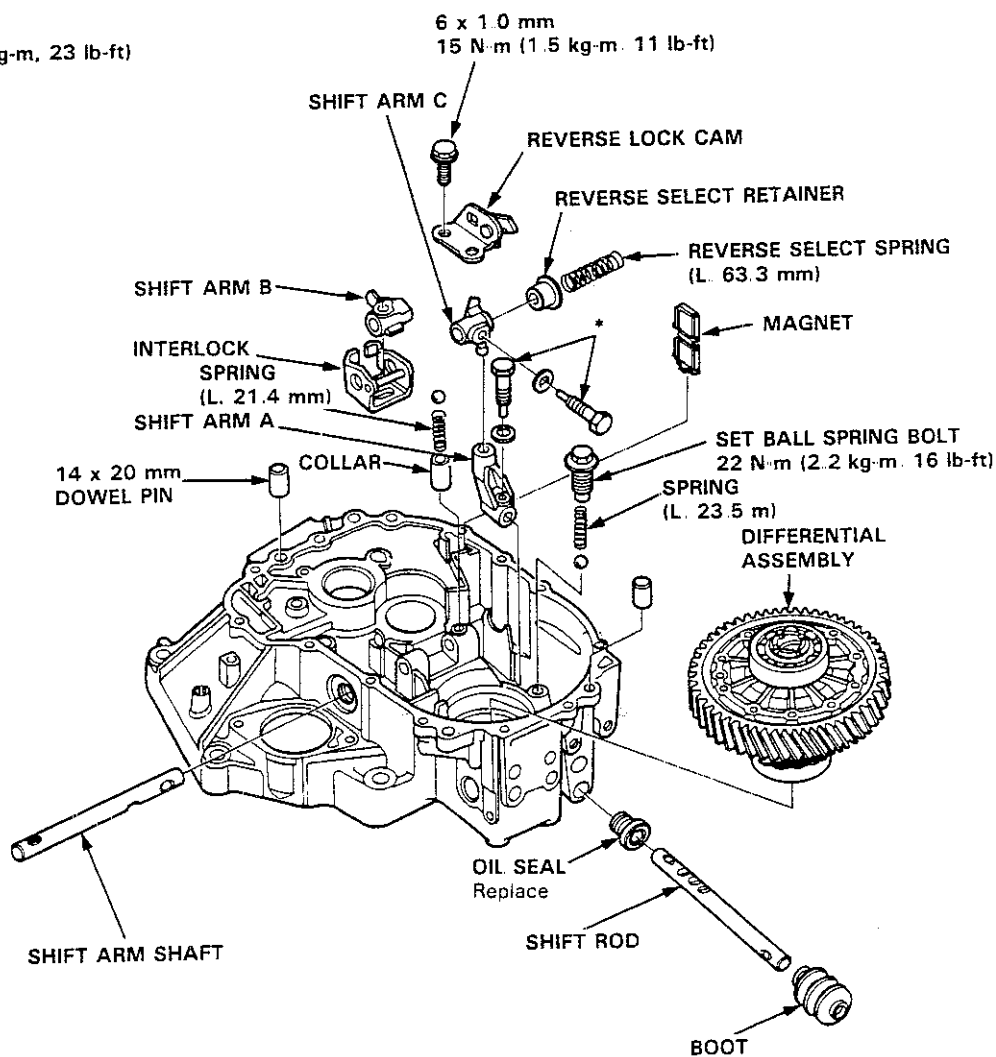

(cont'd)

# Transmission

## Reassembly (cont'd)

11. Set the 36mm spring washer and washer
12. Install the mainshaft, countershaft, and shift fork assemblies.

NOTE: Align the finger of the interlock with the groove in the shift fork shaft

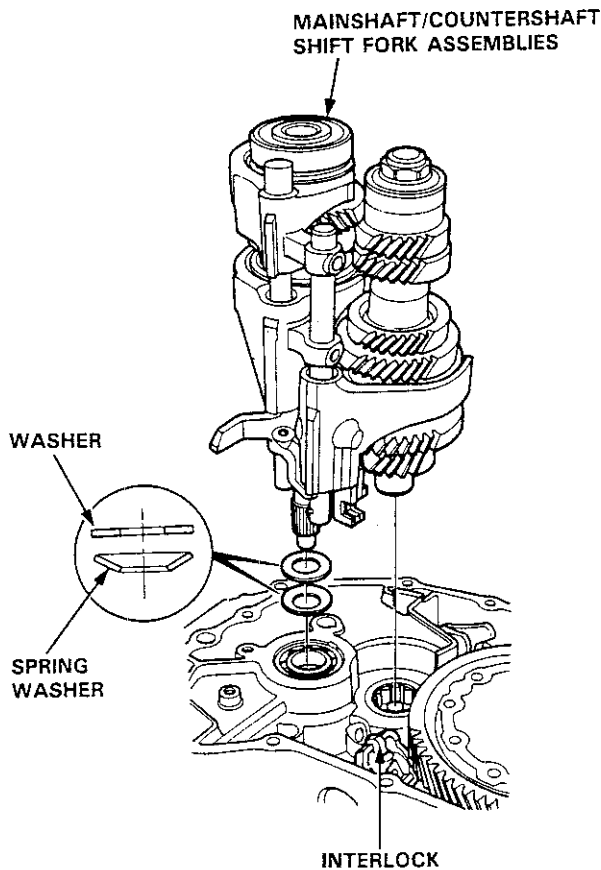

13. Install the spring washer and shift arm B attaching bolt.
14. Install the 1st/2nd select spring, 28mm plug bolt and interlock guide bolt.

NOTE: Apply liquid gasket (P/N OY740-99986) to the threads of the 28 mm plug bolt and interlock guide bolt

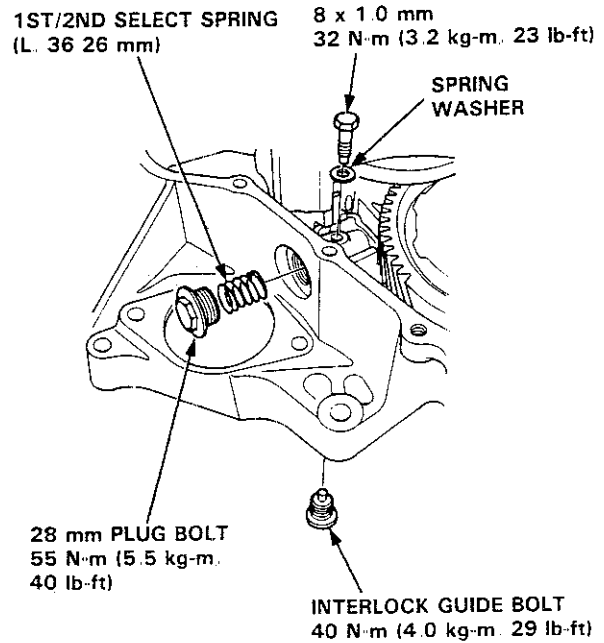

15. Install the reverse idler gear and reverse idler gear shaft.

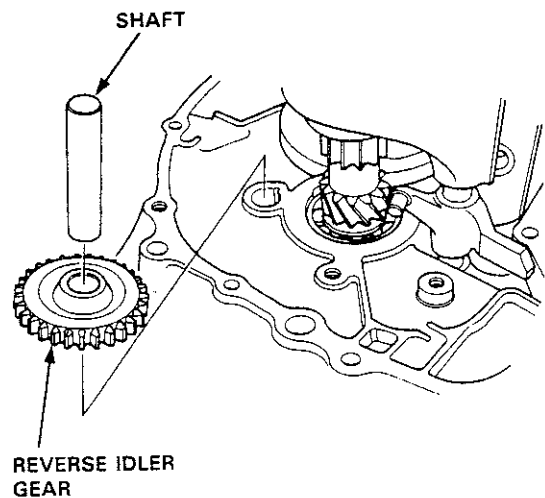



16 Install the reverse shift holder.

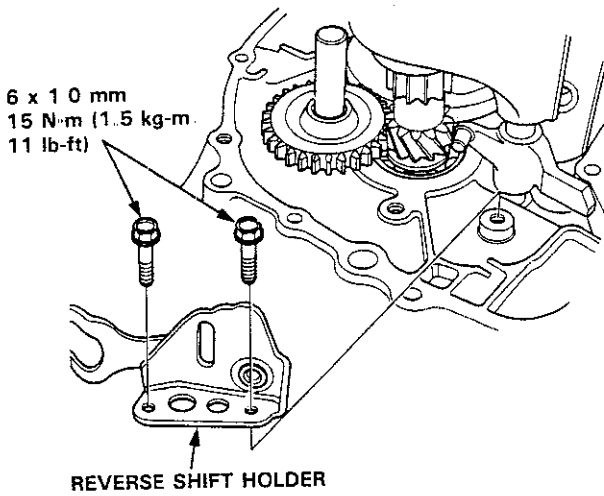

17 Install the oil guide plate and 70 mm thrust shim on the transmission housing.

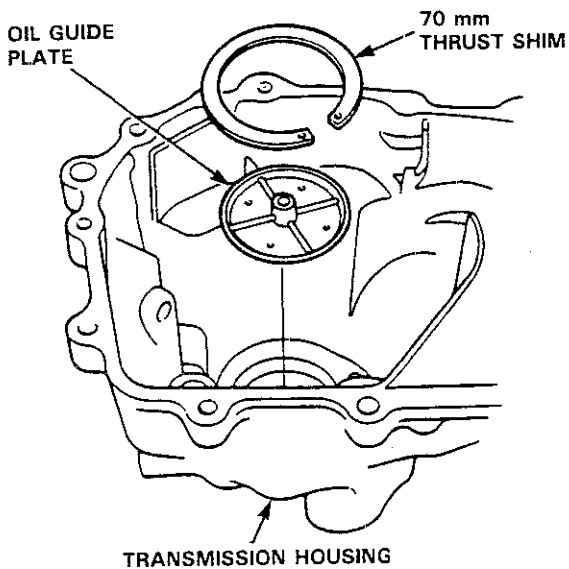

18 Install the oil gutter plate and 10 mm sealing bolt

NOTE: Apply liquid gasket (P/N OY740-99986) to the threads of the 10 mm sealing bolt

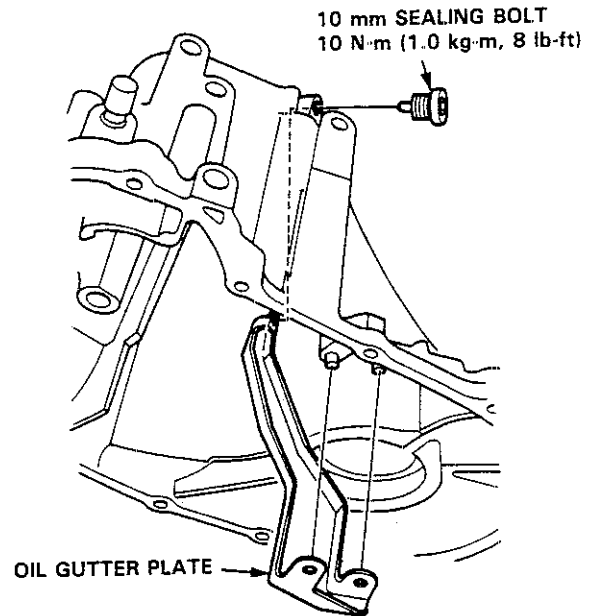

19 Apply liquid gasket to the transmission mating surface of the clutch housing

NOTE: This transmission uses no gaskets between the major housings; use liquid gasket (P/N OY740-99986). Assemble the housing within 20 minutes after applying the liquid gasket and allow it to cure at least 30 minutes after assembly before filling it with oil.

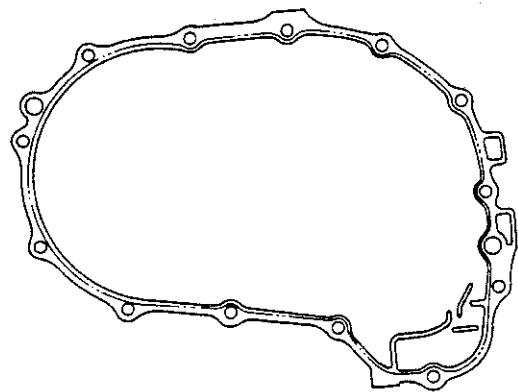

(cont'd)

# Transmission

## Reassembly (cont'd)

20. Install the dowel pins and the transmission housing
21. Lower the transmission housing with the snap ring expanded and set the snap ring in the groove of the countershaft bearing

NOTE: Check that the snap ring is securely seated in the groove of the countershaft bearing

22. Install the 32 mm sealing bolt.

NOTE: Apply liquid gasket (P/N OY740--99986) to the threads.

32 mm SEALING BOLT  
25 N·m (2.5 kg·m, 18 lb-ft)

SNAP RING PLIER  
07LGC-0010100

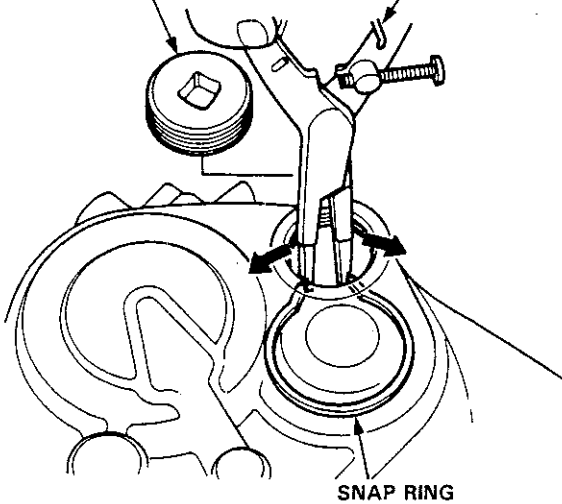

4.6-8.3 mm  
(0.18-0.33 in)

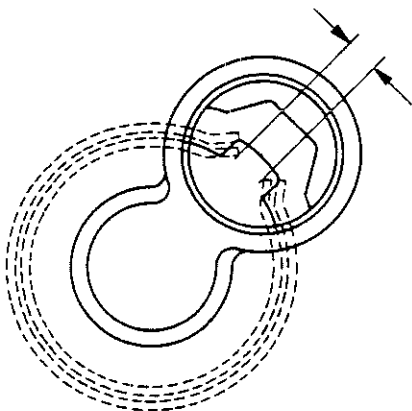

23. Tighten the transmission housing attaching bolts in the numbered sequence shown below

8 x 1.25 mm

Torque: 28 N·m (2.8 kg·m, 20 lb-ft)

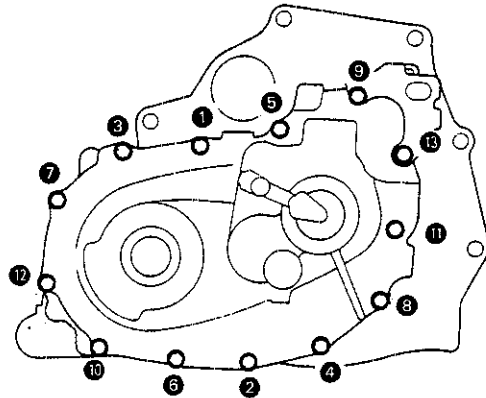

24. Install the back-up light switch and transmission hanger B

8 x 1.25  
28 N·m (2.8 kg·m, 20 lb-ft)

TRANSMISSION  
HANGER B

WASHER  
Replace

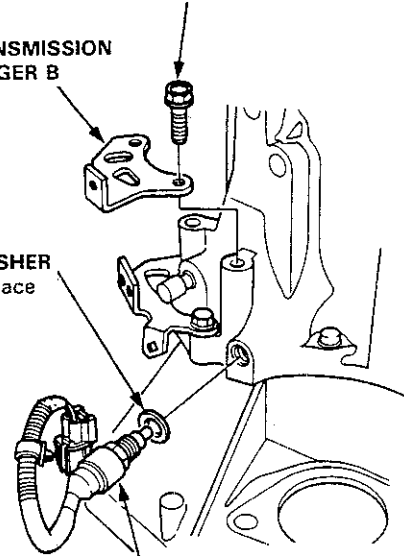

BACK-UP LIGHT SWITCH  
25 N·m (2.5 kg·m, 18 lb-ft)



# Transmission Assembly

## Installation

- 1 Install the dowel pins.

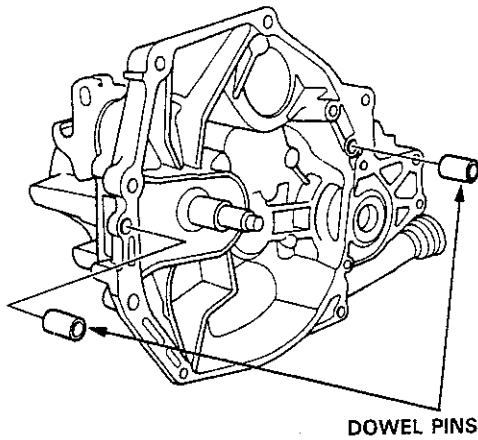

2. Apply grease to the parts as shown.

NOTE: Use only Super High Temp Urea Grease (P/N 08798-9002).

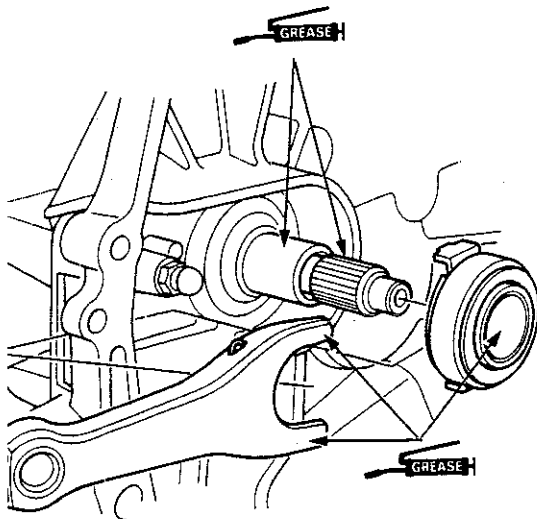

3. Install the release fork boot

- 4 Place the transmission on the transmission jack, and raise it to the engine level.
5. Install the transmission mounting bolts and rear mount bolts.

12 x 1.25 mm  
60 N·m (6.0 kg-m, 43 lb-ft)

14 x 1.5 mm  
85 N·m (8.5 kg-m, 61 lb-ft)

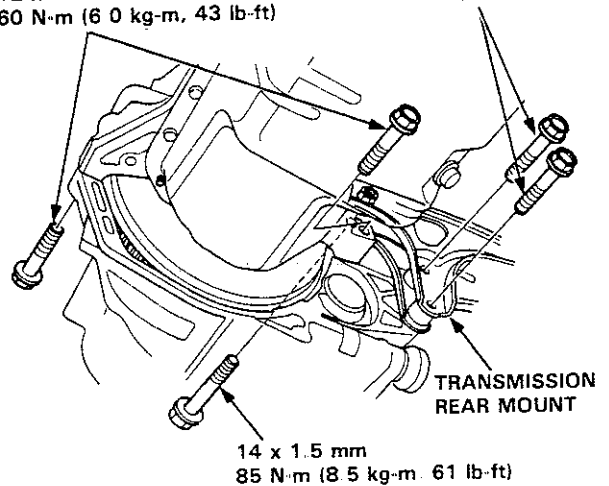

- 6 Raise the transmission, then install the transmission side mount

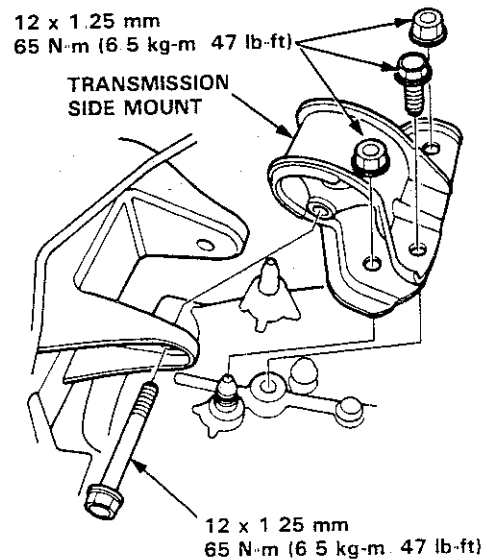

(cont'd)

# Transmission Assembly

## Installation (cont'd)

7. Remove the chain hoist, then reinstall the distributor mounting bolt.

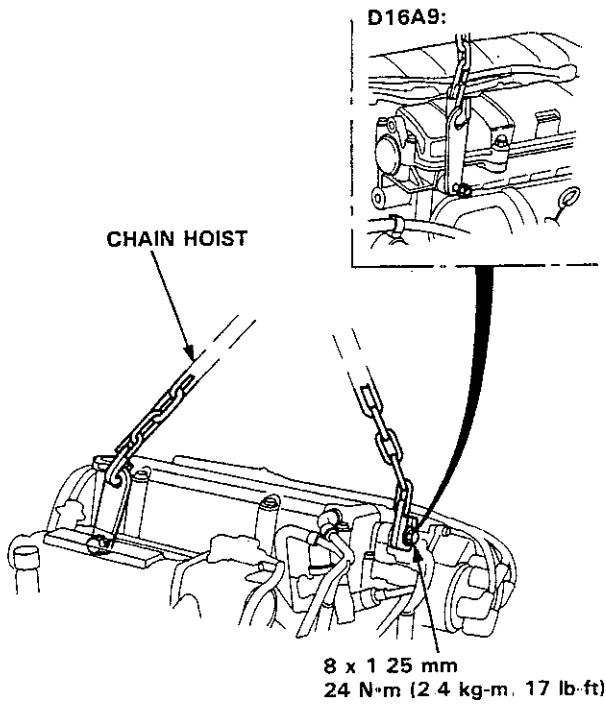

8. Install the clutch cover and engine stiffeners.

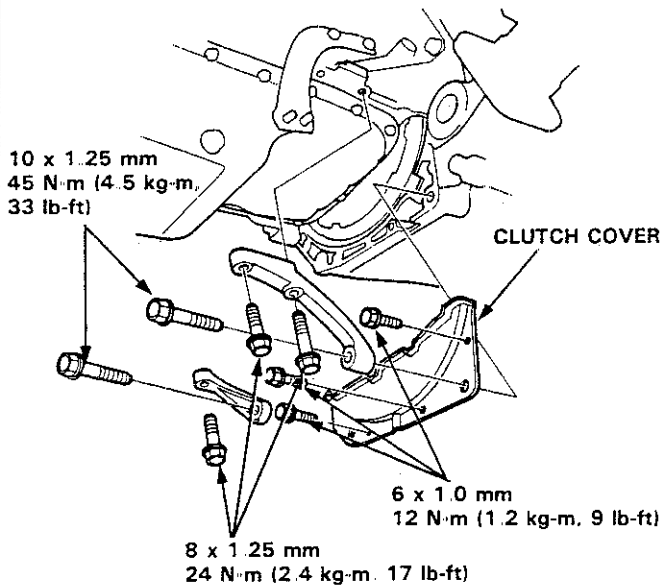

9. Install the front stopper bracket

10. Install the splash guard

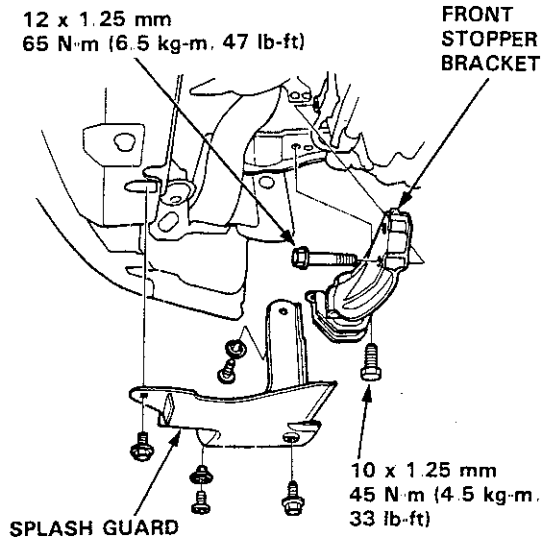

11. Install the change rod, spring pin, and clip.

**NOTE:**

- Install the clip as shown.
- Turn the boot hole down.
- Make sure the boot is installed on the change rod

12. Install the change extension

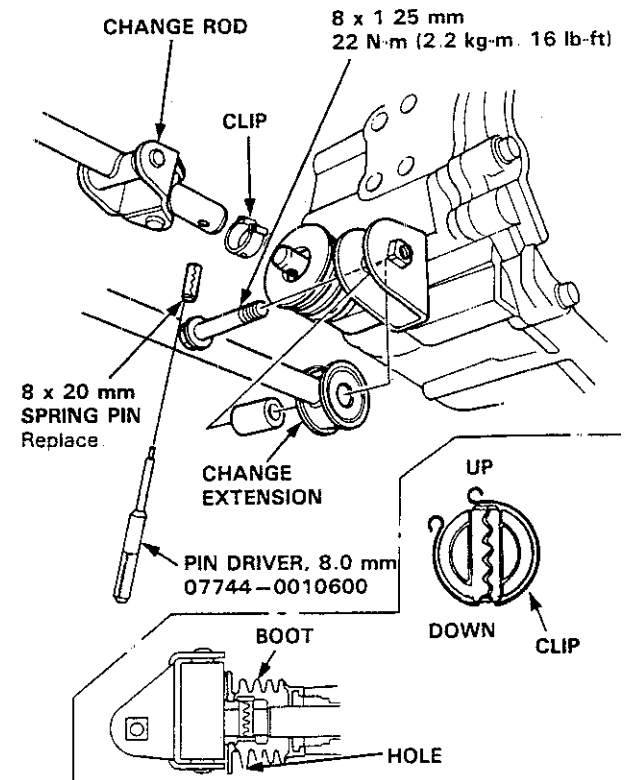





13 Install exhaust pipe A, then connect the connector.

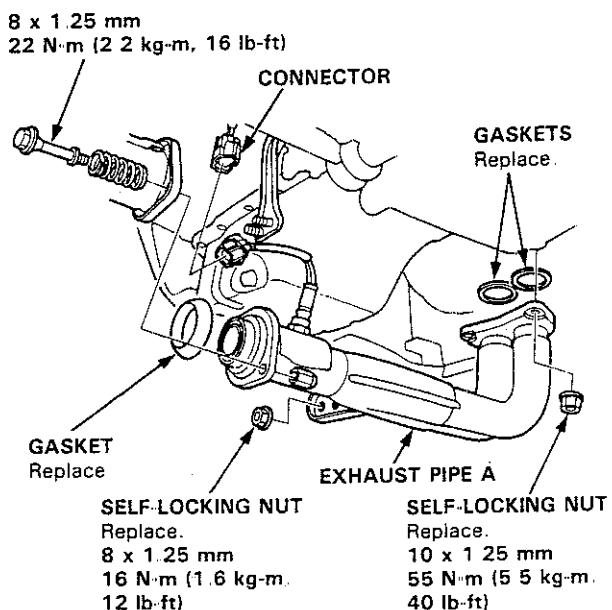

14 Install the intermediate shaft and driveshafts (see section 16)

NOTE: Use the set rings with new ones.

15 Install the ball joint onto the lower arm (see section 16)

16 Install the damper fork.

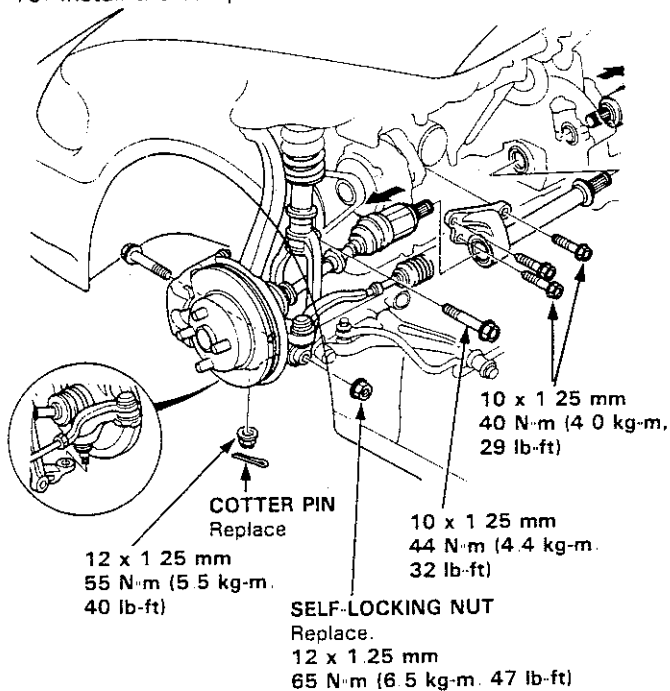

17. Install the transmission mounting bolts.

12 x 1.25 mm  
60 N·m (6.0 kg-m, 43 lb-ft)

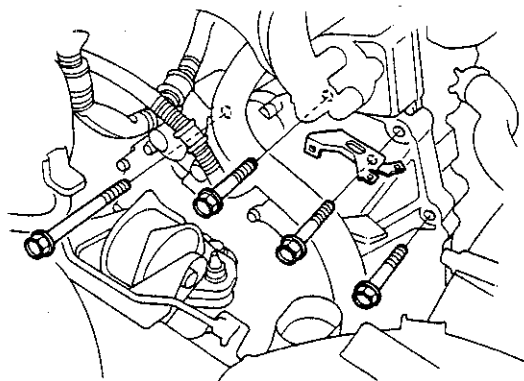

18. Install the slave cylinder, then install the clutch pipe stay.

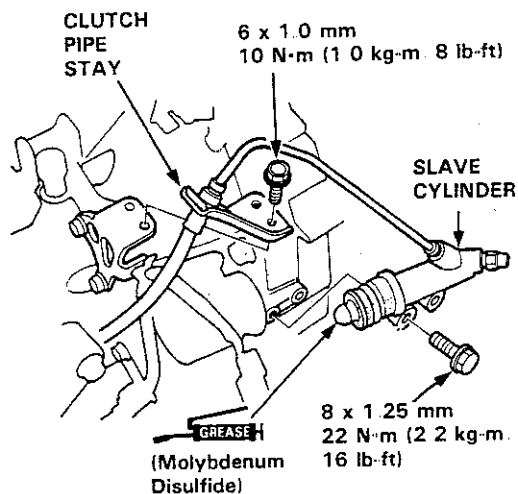

(cont'd)

# Transmission Assembly

## Installation (cont'd)

19. Connect the vehicle speed sensor and back-up light switch connectors and transmission ground wire
20. Install the wire harness clamp.

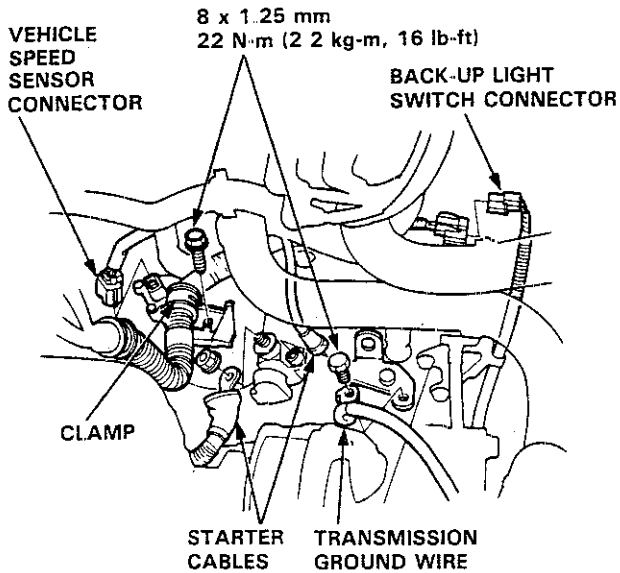

21. Install the resonator, air cleaner housing, and air flow tube

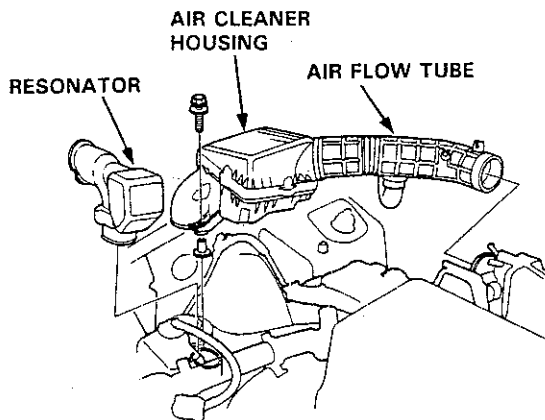

22. Refill the transmission with oil (see page 13-3)
23. Connect the positive (+) and negative (-) cables to the battery.
24. Check the clutch operation
25. Shift the transmission and check for smooth operation



# Gearshift Mechanism

## Overhaul

### NOTE:

- Install the clip as shown.
- Turn the boot hole down.
- Make sure the boot is installed on the change rod.

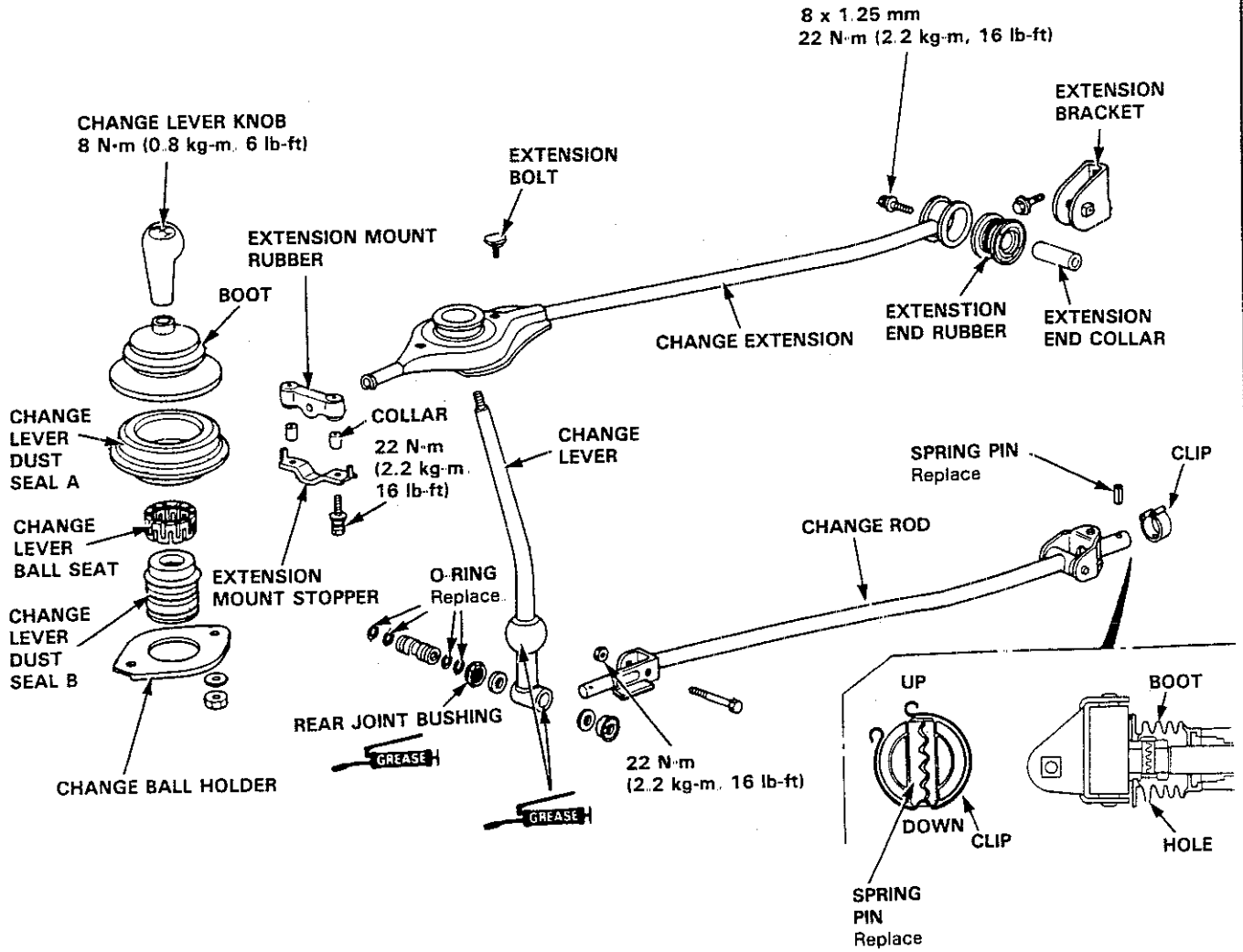



# Y21 Model Manual Transmission

Special Tools .....	13-44	Mainshaft Assembly	
Maintenance .....	13-45	Index .....	13-61
Back-up Light Switch		Clearance Inspection .....	13-62
Replacement .....	13-45	Disassembly .....	13-63
Transmission Assembly		Inspection .....	13-64
Removal .....	13-46	Reassembly .....	13-65
Gearshift Mechanism		Countershaft Assembly	
Overhaul .....	13-47	Index .....	13-66
Illustrated Index .....	13-48	Clearance Inspection .....	13-67
Transmission Housing		Disassembly .....	13-68
Removal .....	13-50	Inspection .....	13-69
Reverse Shift Fork, Reverse Idler Gear		Reassembly .....	13-70
Clearance Inspection .....	13-51	Synchro Ring, Gear	
Removal .....	13-52	Inspection .....	13-72
Change Holder Assembly		Synchro Sleeve, Synchro Hub	
Clearance Inspection .....	13-53	Inspection .....	13-73
Removal .....	13-55	Installation .....	13-73
Disassembly/Reassembly .....	13-56	Clutch Housing Bearing	
Mainshaft, Countershaft, Differential		Replacement .....	13-74
Assemblies		Mainshaft Thrust Shim	
Removal .....	13-57	Adjustment .....	13-76
Shift Rod		Transmission	
Removal .....	13-58	Reassembly .....	13-79
Shift Fork, Shift Piece		Transmission Assembly	
Clearance Inspection .....	13-58	Installation .....	13-83
Shift Fork Assembly			
Disassembly/Reassembly .....	13-60		



# Special Tools

## Special Tools

Ref. No.	Tool Number	Description	Qty	Remarks
①	07GAJ-PG20102	Mainshaft Clearance Inspection Tools Set	1	Component Tools
①-1	07GAJ-PG20110	Mainshaft Holder	(1)	
①-2	07GAJ-PG20130	Mainshaft Base	(1)	Component Tools
②	07JAC-PH80000	Adjustable Bearing Remover Set	1	
②-1	07JAC-PH80100	Bearing Remover Attachment	(1)	Component Tools
②-2	07JAC-PH80200	Remover Handle Assembly	(1)	
②-3	07741-0010201	Remover Weight	(1)	
③	07LGC-0010100	Snap Ring Plier	1	
④	07744-0010200	Pin Driver, 3.0 mm	1	
⑤	07744-0010400	Pin Driver, 5.0 mm	1	
⑥	07744-0010600	Pin Driver, 8.0 mm	1	
⑦	07746-0010300	Outer Driver, 42 x 47 mm	1	
⑧	07746-0010400	Outer Driver, 52 x 55 mm	1	
⑨	07746-0030100	Inner Handle C	1	
⑩	07746-0030300	Inner Driver, 30 mm	1	
⑪	07746-0030400	Inner Driver, 35 mm	1	
⑫	07746-0041100	Pilot Driver, 28 mm	1	
⑬	07749-0010000	Outer Handle A	1	
⑭	07979-PJ40001	Magnet Stand Base	1	

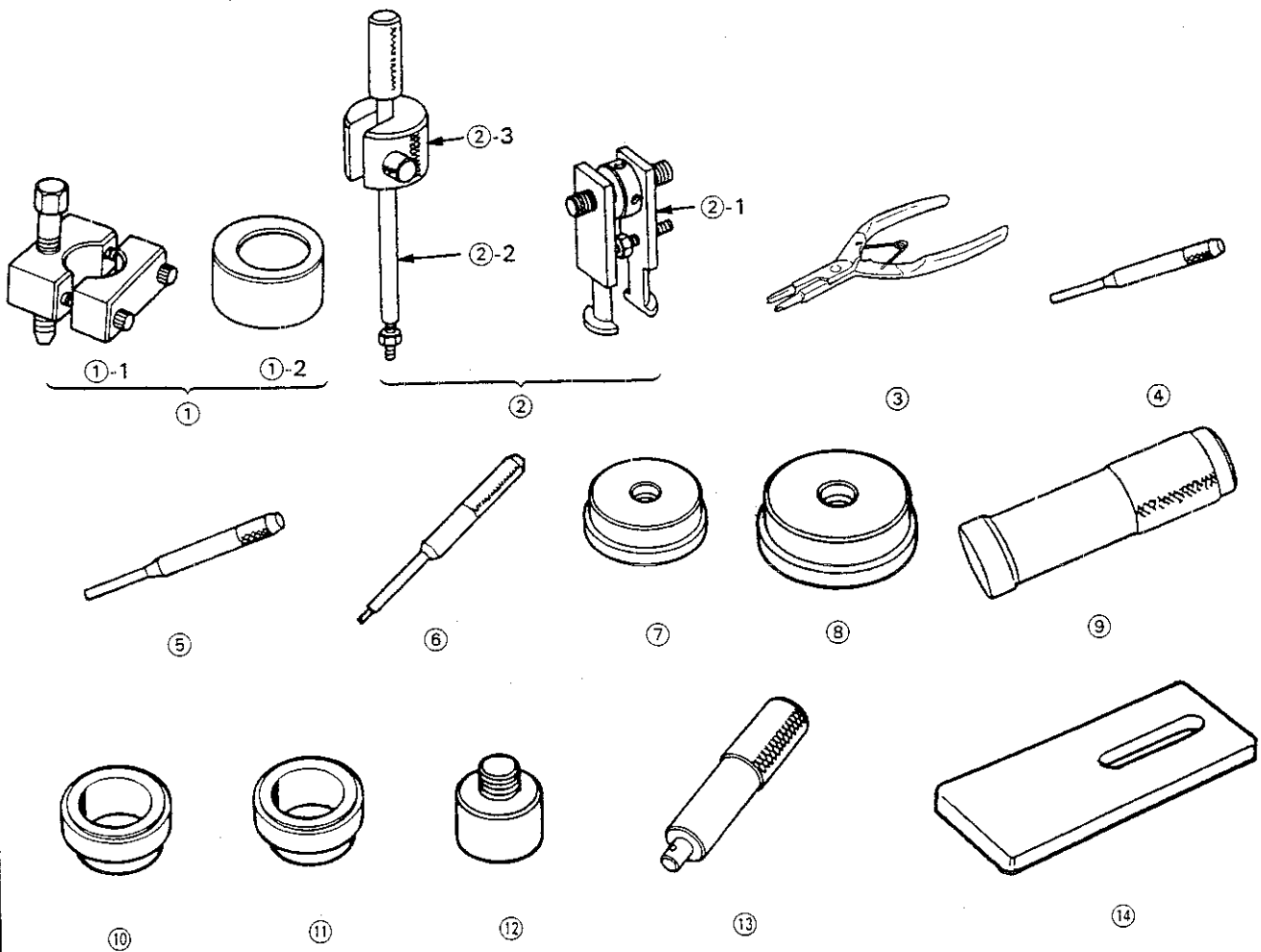



# Maintenance

## Transmission Oil

NOTE: Check the oil at operating temperature, engine OFF, and the car on level ground.

- 1 Remove the oil filler plug, then check the level and condition of the oil.

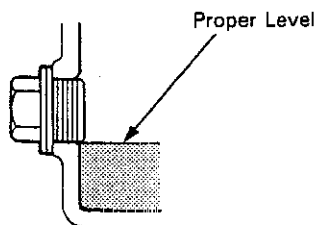

2. The oil level must be up to the filler hole. If it is below the hole, refill oil until it runs out, then reinstall the oil filler plug.
3. If the oil is dirty, remove the drain plug and drain transmission oil.
4. Reinstall the drain plug with a new washer, and refill to proper level.

NOTE: The drain plug washer should be replaced at every oil change.

- 5 Reinstall the oil filler plug with a new washer

### Oil Capacity

2.3 l (2.4 U.S. qt., 20 Imp. qt.) at oil change.

2.4 l (2.5 U.S. qt., 21 Imp. qt.) at overhaul.

Use only SEA 10W-30 or 10W-40, SF or SG grade

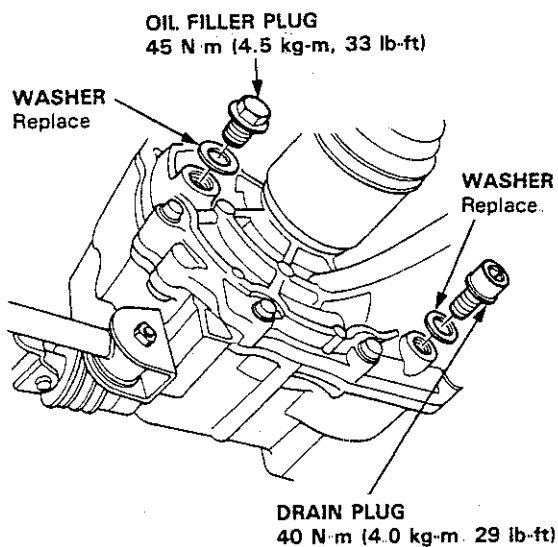

# Back-up Light Switch

## Replacement

NOTE: To check the switch, see section 23.

1. Disconnect the connector, then remove the switch connector from the connector clamp.
2. Remove the switch
3. Install the new washer and switch

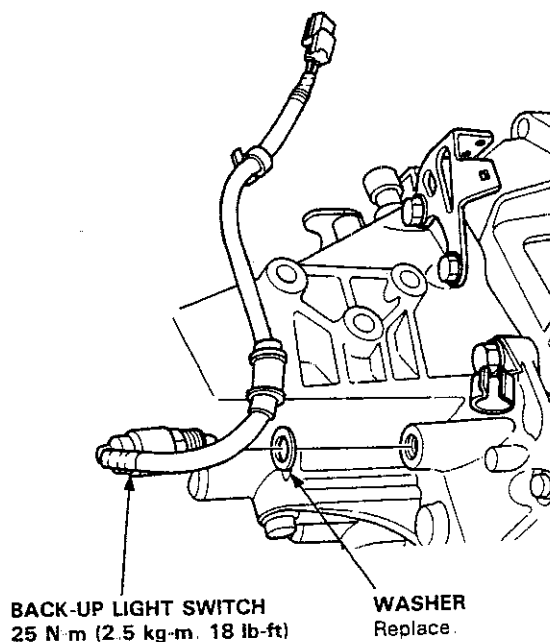

# Transmission Assembly

## Removal

NOTE: Differences between the S20 model MT and Y21 model MT are covered on this page. Refer to page 13-4 for the information not covered on this page.

- 1 Remove the change extension and change rod

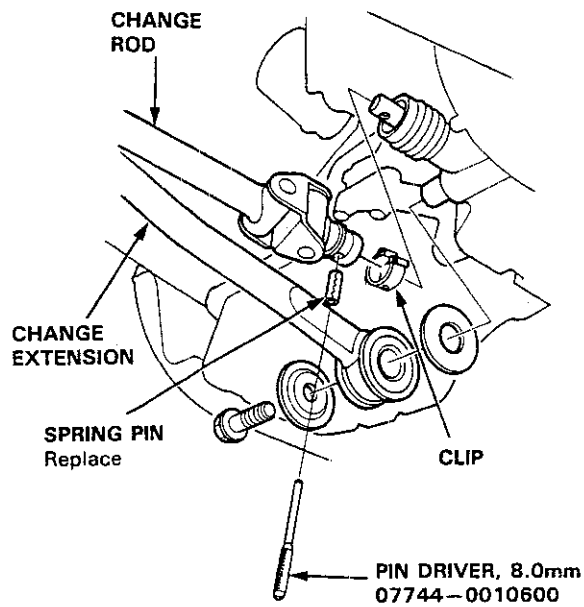

- 2 Remove the transmission rear mount bolts and transmission mounting bolts.

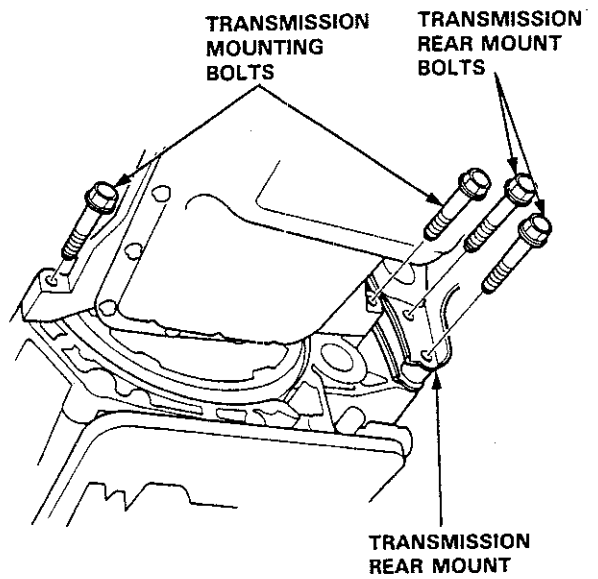





# Gearshift Mechanism

## Overhaul

### NOTE:

- Install the clip as shown.
- Turn the boot hole down
- Make sure the boot is installed on the change rod

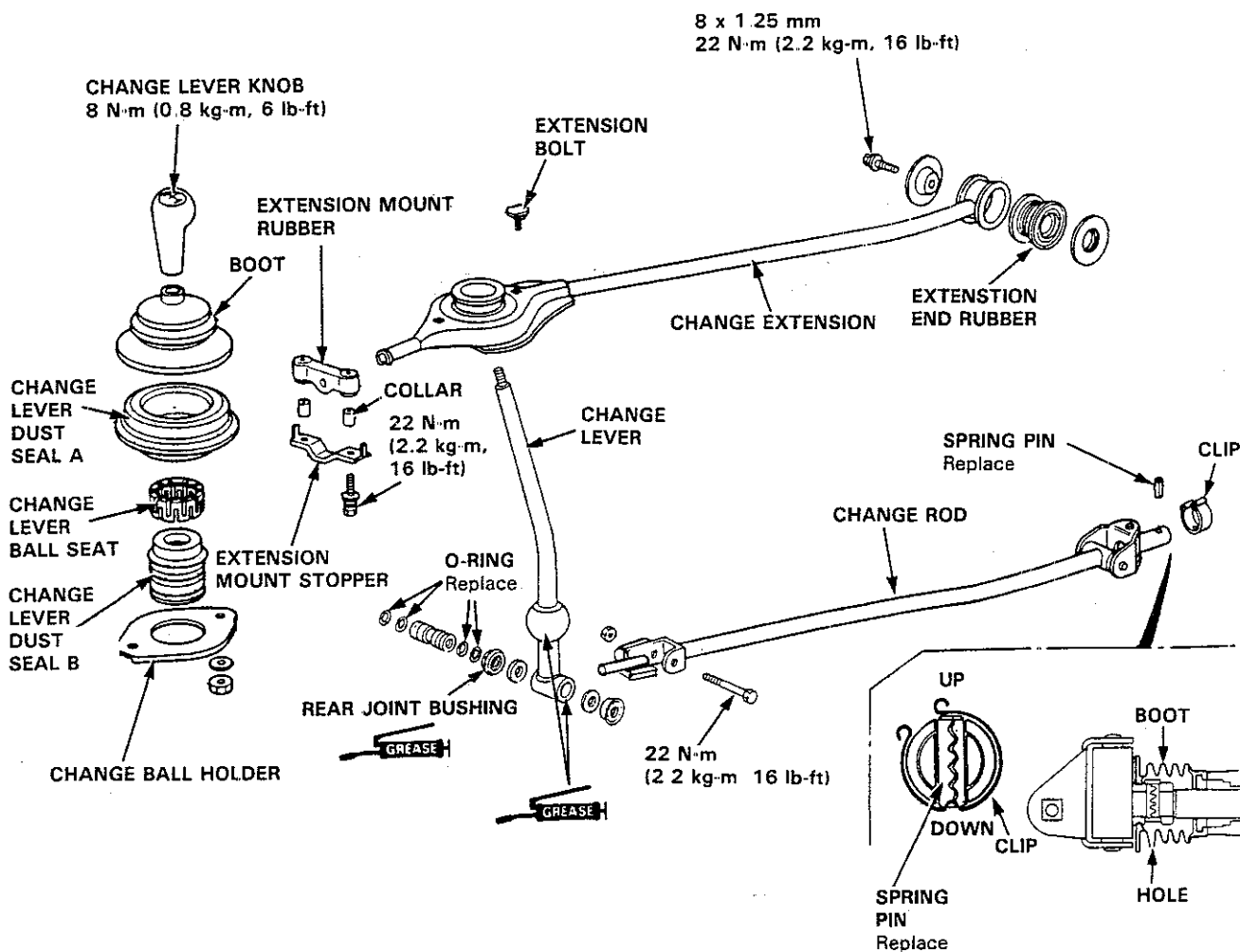

# Illustrated Index

Refer to the drawing below for the transmission disassembly/reassembly.  
Clean all parts thoroughly in solvent and dry with compressed air.

 Lubricate all parts with oil before reassembly

NOTE: This transmission uses no gaskets between the major housings; use Honda Genuine Liquid Gasket (P/N OY740-99986) Assemble the housings within 20 minutes after applying the sealant and allow it to cure at least 30 minutes after assembly before filling the transmission with oil.

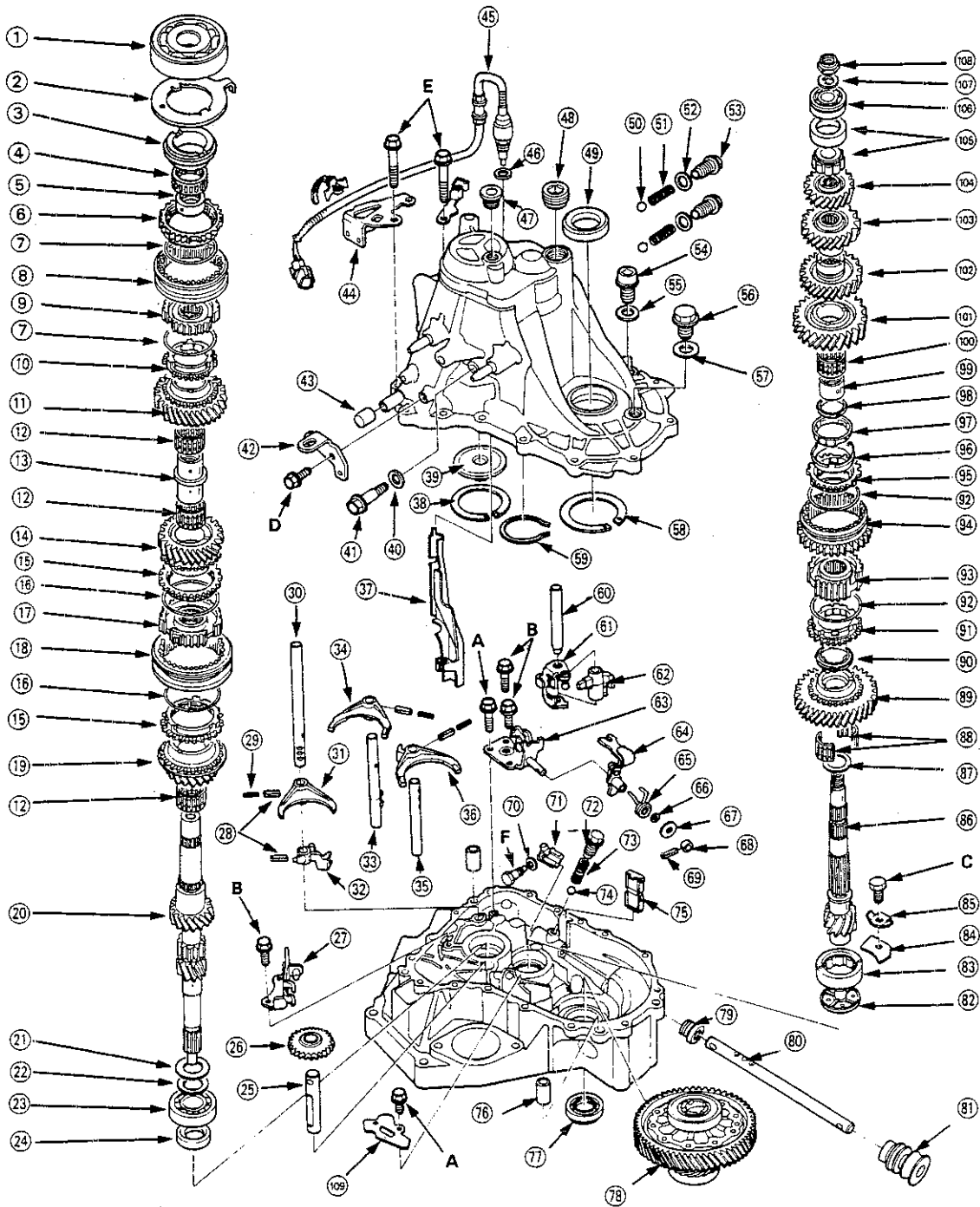



NOTE: Always clean the magnet ⑦⑤ whenever the transmission housing is disassembled.

	Bolt Size	Torque Value
A	6 x 1.0 mm	12 N·m (1.2 kg-m, 9 lb-ft)
B	6 x 1.0 mm	15 N·m (1.5 kg-m, 11 lb-ft)
C	8 x 1.0 mm	15 N·m (1.5 kg-m, 11 lb-ft)
D	8 x 1.25 mm	24 N·m (2.4 kg-m, 17 lb-ft)
E	8 x 1.25 mm	28 N·m (2.8 kg-m, 20 lb-ft)
F	8 x 1.0 mm	37 N·m (3.7 kg-m, 27 lb-ft)

- |                                    |   |   |
|------------------------------------|---|---|
| ① BALL BEARING                     | ④① REVERSE IDLER GEAR SHAFT BOLT<br>55 N·m (5.5 kg-m, 40 lb-ft) | ⑦⑤ MAGNET   |
| ② STOPPER RING                     | ④② TRANSMISSION HANGER B  | ⑦⑥ 14 x 20 mm DOWEL PIN   |
| ③ TAPER RING                       | ④③ BREATHER CAP   | ⑦⑦ 35 x 56 x 8 mm OIL SEAL<br>Replace.  |
| ④ NEEDLE BEARING                   | ④④ TRANSMISSION HANGER A  | ⑦⑧ DIFFERENTIAL ASSEMBLY<br>See section 15  |
| ⑤ COLLAR                           | ④⑤ BACK-UP LIGHT SWITCH<br>25 N·m (2.5 kg-m, 18 lb-ft)          | ⑦⑨ 14 x 25 x 16 mm OIL SEAL<br>Replace.   |
| ⑥ SYNCHRO RING                     | ④⑥ 14 mm WASHER Replace   | ⑧① SHIFT ROD  |
| ⑦ SYNCHRO SPRING                   | ④⑦ 16 mm SEALING BOLT<br>30 N·m (3.0 kg-m, 22 lb-ft)            | ⑧② BOOT   |
| ⑧ 5TH/REVERSE SYNCHRO SLEEVE       | ④⑧ 32 mm SEALING BOLT<br>25 N·m (2.5 kg-m, 18 lb-ft)            | ⑧③ OIL GUIDE PLATE  |
| ⑨ 5TH/REVERSE SYNCHRO HUB          | ④⑨ 40 x 62 x 9 mm OIL SEAL Replace.                             | ⑧④ 33 x 60 x 20 mm<br>NEEDLE BEARING  |
| ⑩ SYNCHRO RING                     | ⑤① STEEL BALL (5/16 in)   | ⑧⑤ BEARING RETAINER PLATE   |
| ⑪ 5TH GEAR                         | ⑤② SPRING (L. 30 mm)  | ⑧⑥ LOCK WASHER  |
| ⑫ 38 x 43 x 26 mm NEEDLE BEARING   | ⑤③ 12 mm WASHER Replace   | ⑧⑦ COUNTERSHAFT   |
| ⑬ SPACER COLLAR                    | ⑤④ SET BOLT<br>22 N·m (2.5 kg-m, 16 lb-ft)                      | ⑧⑧ 40 x 50 mm THRUST SHIM   |
| ⑭ 4TH GEAR                         | ⑤⑤ OIL FILLER PLUG<br>45 N·m (4.5 kg-m, 33 lb-ft)               | ⑧⑨ 37 x 42 x 25 mm<br>NEEDLE BEARING  |
| ⑮ SYNCHRO RING                     | ⑤⑥ 20 mm WASHER Replace.  | ⑧⑩ 1ST GEAR   |
| ⑯ SYNCHRO SPRING                   | ⑤⑦ OIL DRAIN PLUG<br>40 N·m (4.0 kg-m, 28 lb-ft)                | ⑧⑪ FRICTION DAMPER  |
| ⑰ 3RD/4TH SYNCHRO HUB              | ⑤⑧ 14 mm WASHER Replace.  | ⑧⑫ SYNCHRO RING   |
| ⑱ 3RD/4TH SYNCHRO SLEEVE           | ⑤⑨ 80 mm THRUST SHIM  | ⑧⑬ SYNCHRO SPRING   |
| ⑲ 3RD GEAR                         | ⑤⑩ SNAP RING  | ⑧⑭ 1ST/2ND SYNCHRO HUB  |
| ⑳ MAINSHAFT                        | ⑤⑪ SHIFT PIECE SHAFT  | ⑧⑮ REVERSE GEAR   |
| ㉑ WASHER                           | ⑤⑫ INTERLOCK  | ⑧⑯ OUTER SYNCHRO RING   |
| ㉒ SPRING WASHER                    | ⑤⑬ SHIFT PIECE  | ⑧⑰ SYNCHRO CORN   |
| ㉓ BALL BEARING                     | ⑤⑭ SHIFT ARM HOLDER   | ⑧⑱ INNER SYNCHRO RING   |
| ㉔ 28 x 41 x 7 mm OIL SEAL Replace. | ⑤⑮ SELECT ARM   | ⑧⑲ FRICTION DAMPER  |
| ㉕ REVERSE IDLER GEAR SHAFT         | ⑤⑯ SELCT RETURN SPRING  | ⑧⑳ DISTANCE COLLAR  |
| ㉖ REVERSE IDLER GEAR               | ⑤⑰ 10 mm THRUST SHIM  | ⑧㉑ 42 x 47 x 23.5 mm<br>NEEDLE BEARING  |
| ㉗ REVERSE SHIFT FORK               | ⑤⑱ 10 mm WASHER   | ⑩① 2ND GEAR   |
| ㉘ 5 x 22 mm SPRING PIN Replace.    | ⑤⑲ LOCK COLLAR  | ⑩② 3RD GEAR   |
| ㉙ 3 x 22 mm SPRING PIN Replace     | ⑤⑳ 3 x 16 mm SPRING PIN<br>Replace.                             | ⑩③ 4TH GEAR   |
| ㉚ 5TH/REVERSE SHIFT FORK SHAFT     | ⑥① 8 mm SPRING WASHER   | ⑩④ 5TH GEAR   |
| ㉛ 5TH/REVERSE SHIFT FORK           | ⑥② CHANGE PIECE   | ⑩⑤ NEEDLE BEARING   |
| ㉜ 3RD/4TH SHIFT FORK SHAFT         | ⑥③ SEALING BOLT<br>22 N·m (2.2 kg-m, 16 lb-ft)                  | ⑩⑥ BALL BEARING   |
| ㉝ 3RD/4TH SHIFT FORK               | ⑥④ SPRING (L. 23.5 mm)  | ⑩⑦ SPRING WASHER  |
| ㉞ 1ST/2ND SHIFT FORK SHAFT         | ⑥⑤ STEEL BALL   | ⑩⑧ LOCKNUT Replace.<br>110 → 0 → 110 N·m<br>( 11.0 → 0 → 11.0 kg-m )<br>80 → 0 → 80 lb-ft |
| ㉟ 1ST/2ND SHIFT FORK               |   | ⑩⑨ OIL CHAMBER PLATE  |
| ㊱ OIL GUTTER PLATE                 |   |   |
| ㊲ 72 mm THRUST SHIM                |   |   |
| ㊳ OIL GUIDE PLATE                  |   |   |
| ㊴ 10 mm WASHER Replace             |   |   |

# Transmission Housing

## Removal

NOTE: Place the clutch housing on two pieces of wood thick enough to keep the mainshaft from hitting the workbench.

- 1 Remove the back-up light switch
- 2 Remove the transmission hanger B
- 3 Remove the set bolts, springs, and steel balls.

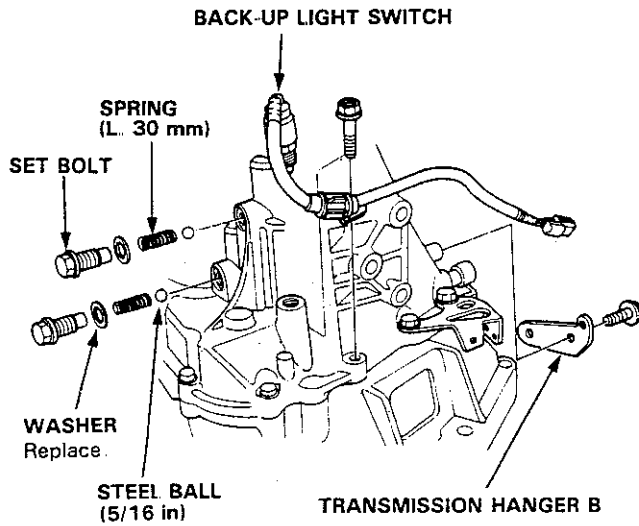

- 2 Remove the reverse idler gear shaft bolt.

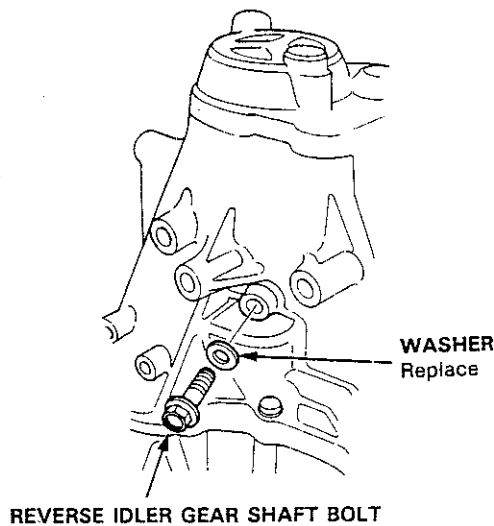

- 3 Loosen the transmission housing attaching bolts in a criss-cross pattern, then remove them.

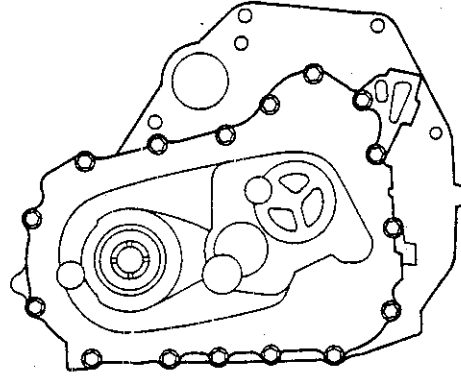

- 4 Remove the 32mm sealing bolt.
- 5 Expand the snap ring on the countershaft ball bearing and remove it from the groove using a pair of snap ring plier

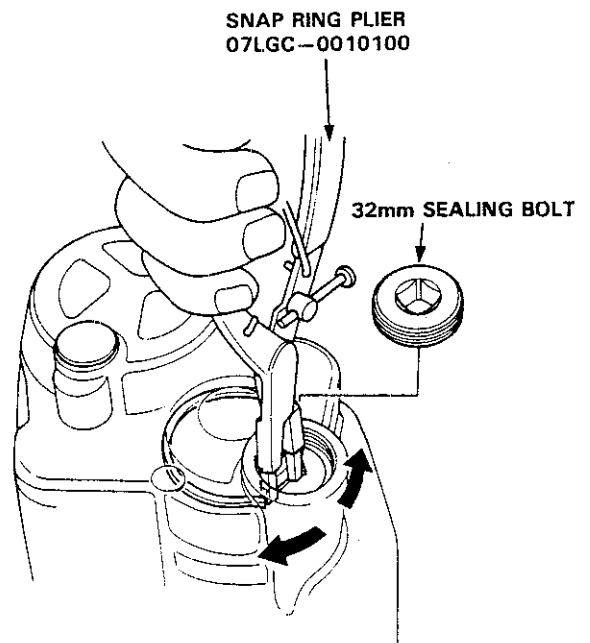

# Reverse Shift Fork, Reverse Idler Gear



## Clearance Inspection

6. Separate the transmission housing from the clutch housing and wipe it clean of the sealant
7. Remove the thrust shim and oil guide plate from the transmission housing.

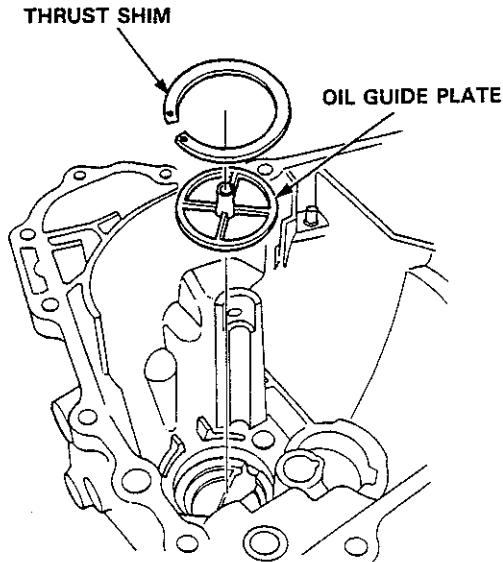

8. Remove the 16mm sealing bolt, then remove the oil gutter plate.

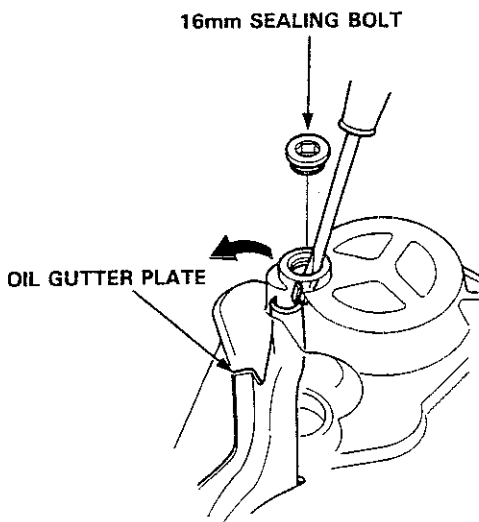

1. Measure the clearance between the reverse shift fork and 5th/reverse shift piece pin.

### Standard:

Reverse Side: 0.05–0.45 mm (0.002–0.018 in)

5th Side: 0.4–0.9 mm (0.016–0.035 in)

### 5TH/REVERSE SHIFT PIECE PIN

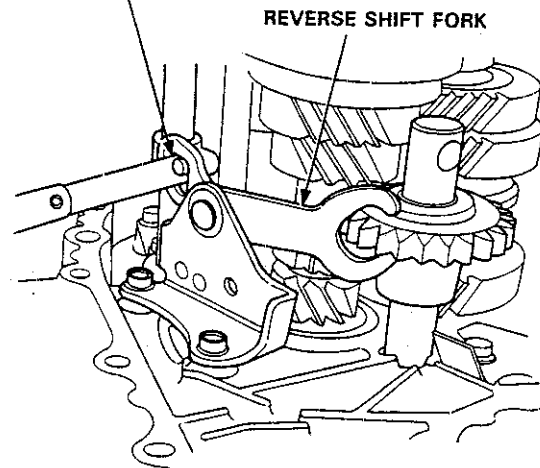

2. If the clearance exceeds the standard, measure the width of the groove in the reverse shift fork.

### Standard:

Reverse Side: 7.05–7.25 mm (0.278–0.285 in)

5th Side: 7.40–7.70 mm (0.291–0.303 in)

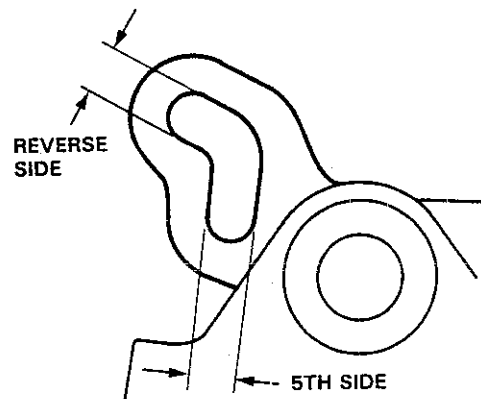

If the width of the groove exceeds the standard, replace the reverse shift fork with a new one.  
If the width of the groove is within the standard, replace the 5th/reverse shift piece with a new one.

(cont'd)

# Reverse Shift Fork, Reverse Idler Gear

## Clearance Inspection (cont'd)

3. Measure the clearance between the reverse idler gear and reverse shift fork

**Standard:** 0.5–1.1 mm (0.020–0.043 in)  
**Service Limit:** 1.8 mm (0.071 in)

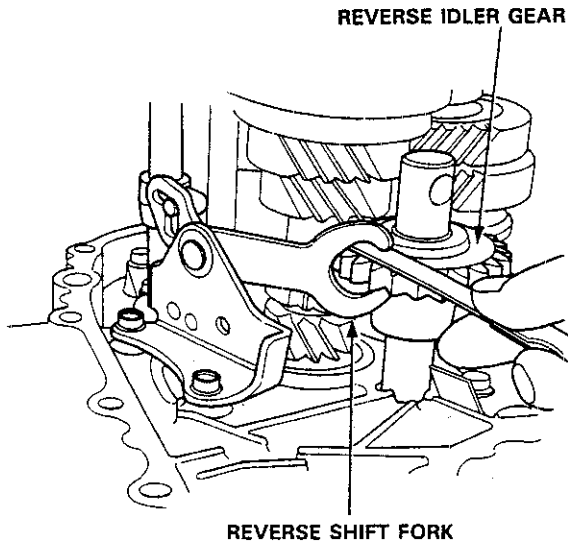

4. If the clearance exceeds the service limit, measure the width of the reverse shift fork pawl groove.

**Standard:** 13.0–13.3 mm (0.512–0.524 in)

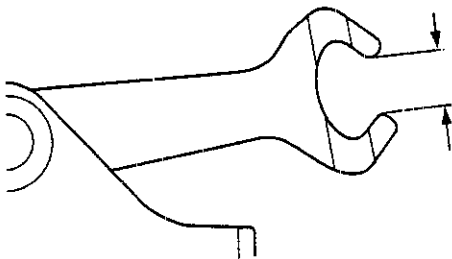

If the width exceeds the standard, replace the reverse shift fork with a new one.  
If the width is within the standard, replace the reverse idler gear with a new one.

## Removal

1. Remove the reverse shift fork.

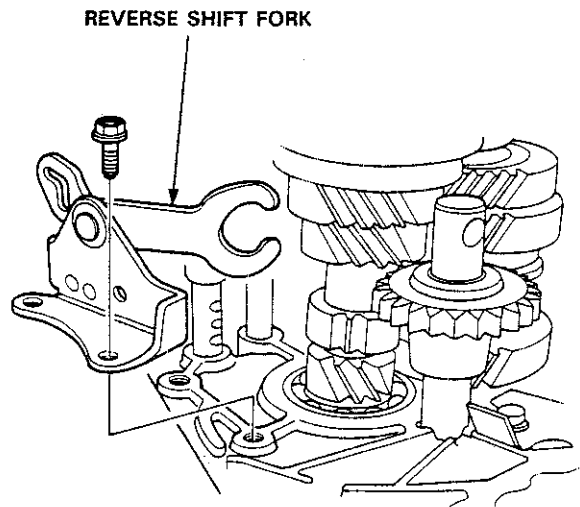

2. Shift the 3rd/4th shift fork to the 4th side, then remove the reverse idler gear and shaft

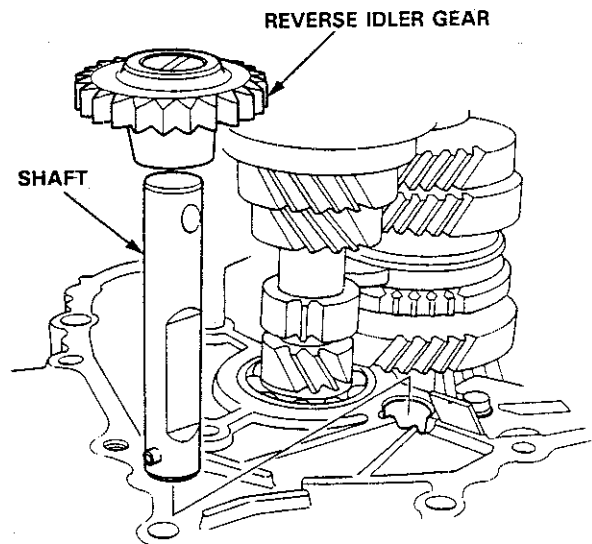



# Change Holder

## Clearance Inspection

- 1 Measure the clearance between the shift piece and shift arm

**Standard:** 0.1–0.3 mm (0.004–0.012 in)  
**Service Limit:** 0.6 mm (0.024 in)

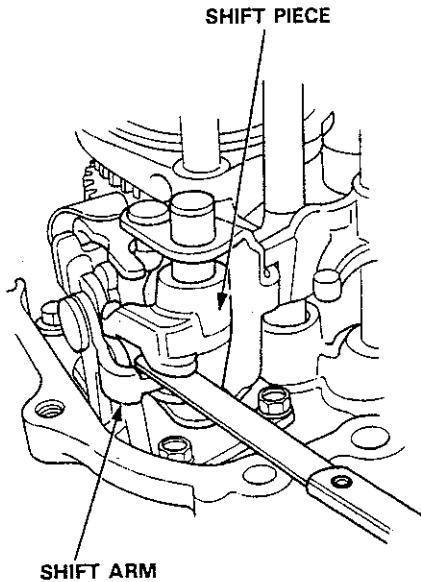

- 2 If the clearance exceeds the service limit, measure the width of the groove in the shift piece.

**Standard:** 8.1–8.2 mm (0.319–0.329 in)

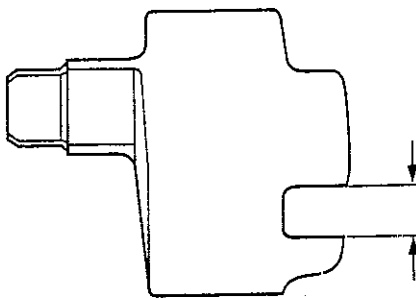

If the width of the groove exceeds the standard, replace the shift piece.  
If the width of the groove is within the standard, replace the shift arm

- 3 Measure the clearance between the select arm and interlock

**Standard:** 0.05–0.25 mm (0.002–0.01 in)  
**Service Limit:** 0.5 mm (0.020 in)

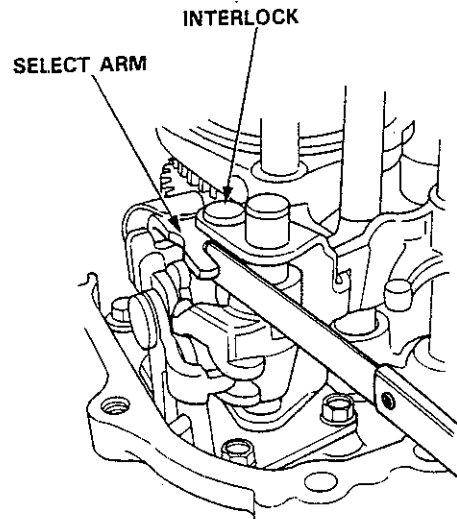

- 4 If the clearance exceeds the service limit, measure the width of the interlock.

**Standard:** 9.9–10.0 mm (0.390–0.394 in)

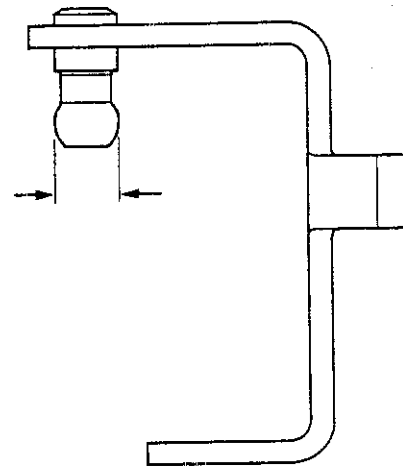

If the width less than the standard, replace the interlock.  
If the width is within the standard, replace the select arm.

(cont'd)

# Change Holder

## Clearance Inspection (cont'd)

7. Measure the clearance between the select arm and shim.

Standard: 0.01–0.2 mm (0.004–0.008 in)

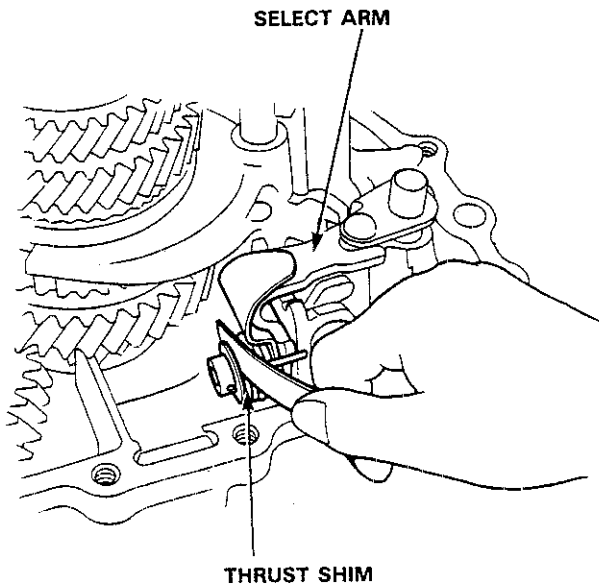

8. If the clearance exceeds the standard, select the appropriate thrust shim for the correct clearance from the chart below

	PART NUMBER	THICKNESS
A	24435–689–000	0.8 mm (0.031 in)
B	24436–689–000	1.0 mm (0.039 in)
C	24437–689–000	1.2 mm (0.047 in)
D	24438–689–000	1.4 mm (0.055 in)
E	24439–689–000	1.6 mm (0.063 in)

9. Measure the clearance between the shift arm holder and change piece

Standard: 0.05–0.35 mm (0.002–0.014 in)  
Service Limit: 0.8 mm (0.031 in)

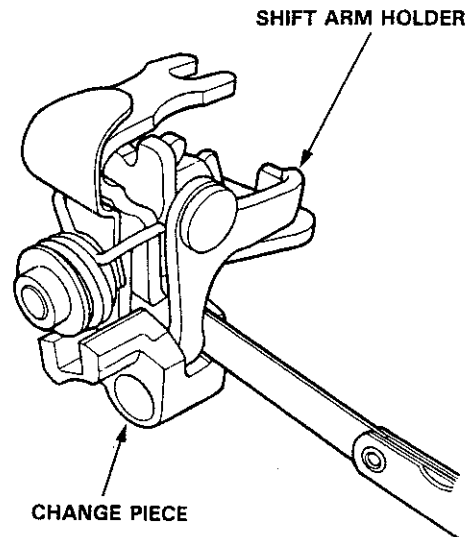

10. If the clearance exceeds the service limit, measure the groove of the change piece.

Standard: 12.05–12.15 mm (0.474–0.478 in)

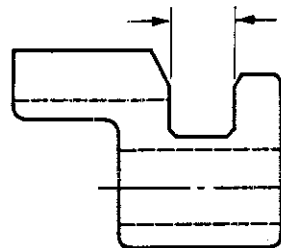

If the groove exceeds the standard, replace the change piece.

If the groove is within the standard, replace the shift arm holder.





- 11 Measure the clearance between the select arm and change piece.

Standard: 0.05–0.25 mm (0.002–0.01 in)  
Service Limit: 0.5 mm (0.020 in)

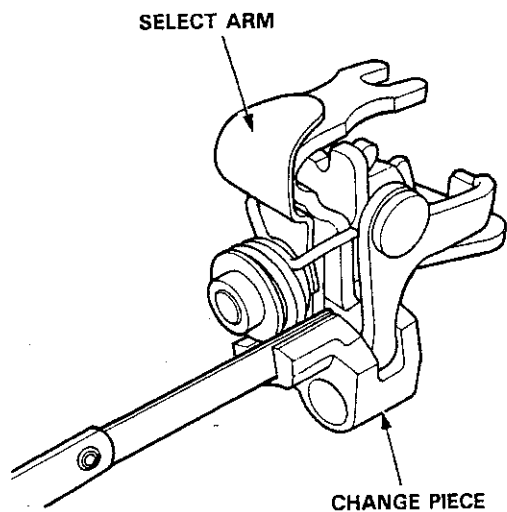

- 12 If the clearance exceeds the service limit, measure the groove of the change piece.

Standard: 12.05–12.15 mm (0.474–0.478 in)

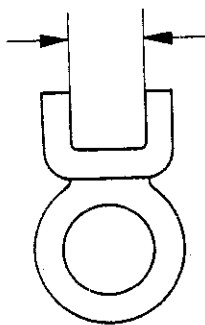

If the groove exceeds the standard, replace the change piece.  
If the groove is within the standard, replace the select arm.

## Removal

1. Remove the shift piece shaft, then remove the shift piece and inter lock.

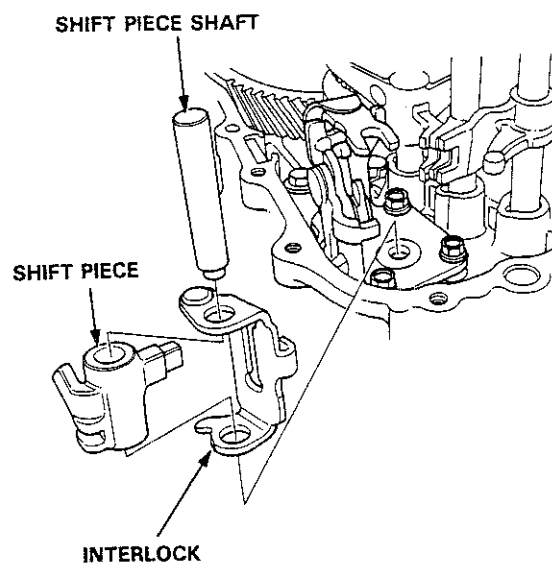

2. Remove the change holder assembly.

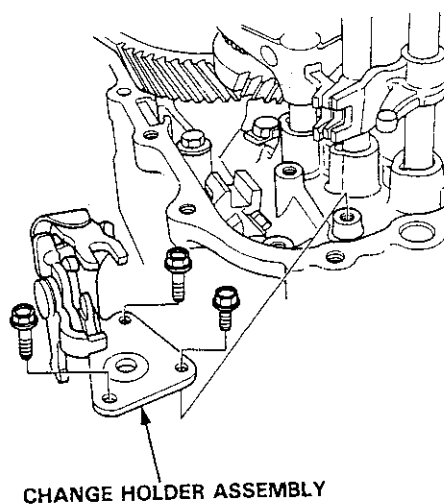

# Change Holder Assembly

## Disassembly/Reassembly



Prior to reassembling, clean all the parts in solvent, dry them and apply lubricant to any contact surfaces.

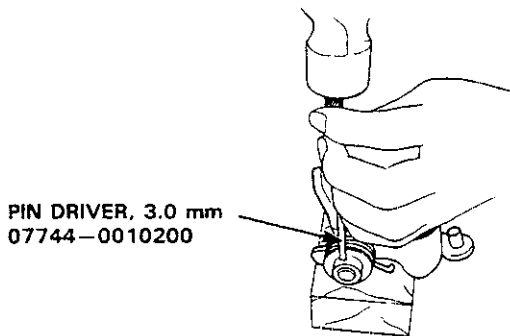
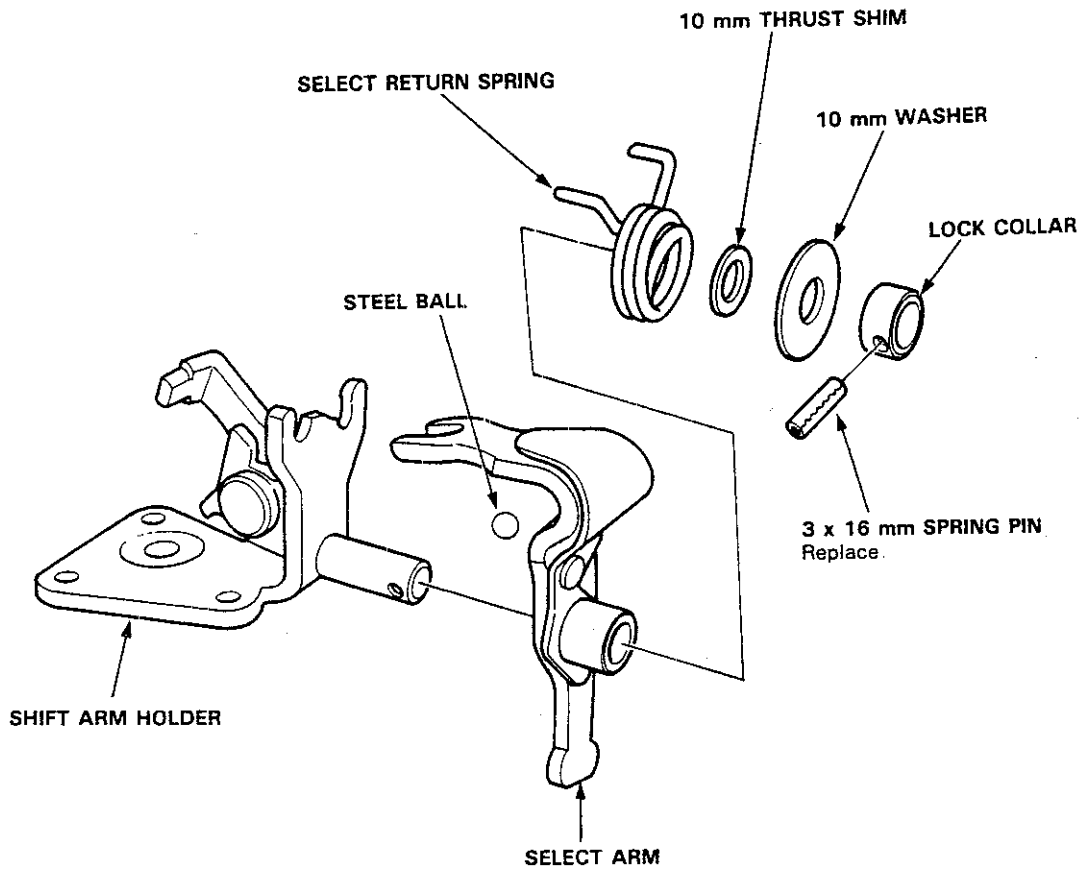

# Mainshaft, Countershaft, Differential Assemblies



## Removal

1. Remove the mainshaft and countershaft assemblies with the shift fork from the clutch housing.

NOTE: Before removing the mainshaft and countershaft assemblies, tape the mainshaft spline to protect it.

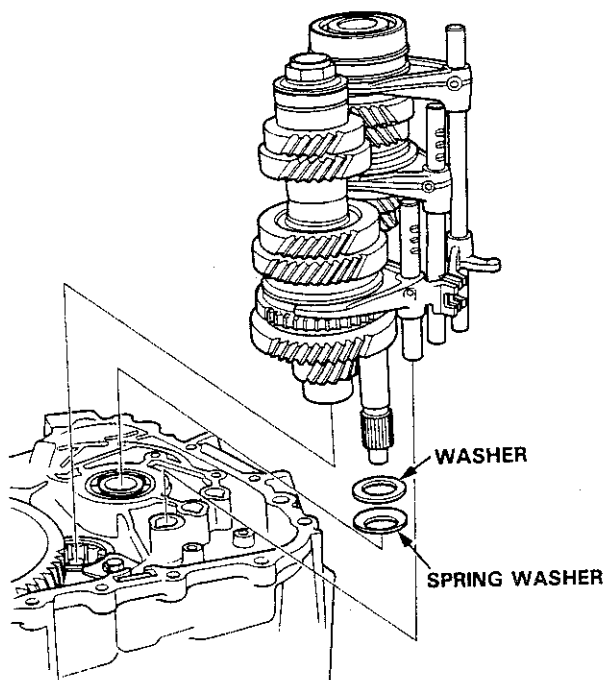

2. Remove the differential assembly.

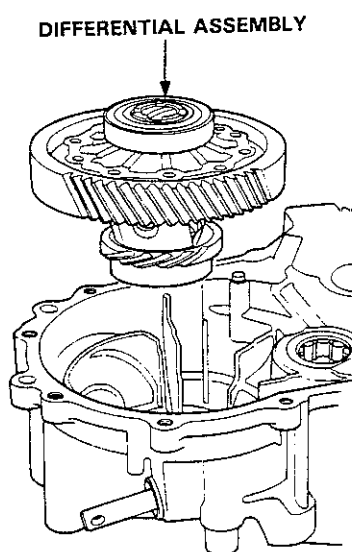

3. Remove the chamber plate.

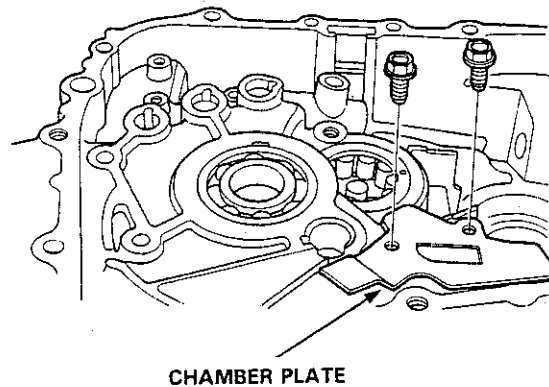

## Shift Rod

### Removal

1. Remove the change piece attaching bolt and spring washer.
2. Remove the set bolt, then remove the spring and steel ball.
3. Remove the shift rod, then remove the change piece

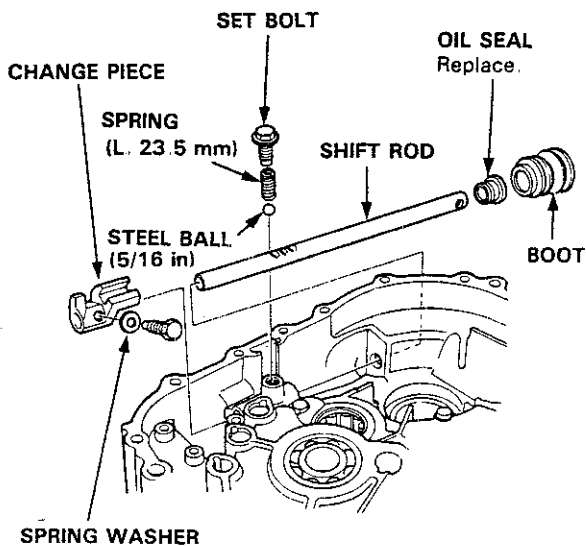

## Shift Fork, Shift Piece

### Clearance Inspection

NOTE: The synchro sleeve and synchro hub should be replaced as a set.

1. Measure the clearance between each shift fork and its matching synchro sleeve.

Standard: 0.45–0.65 mm (0.018–0.026 in)  
Service Limit: 1.0 mm (0.039 in)

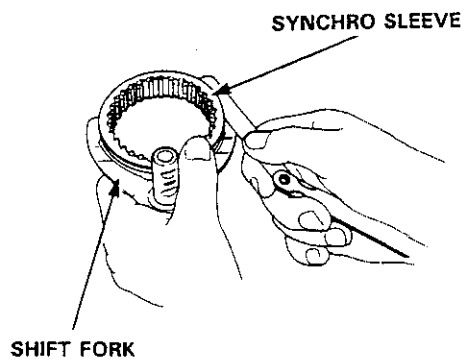

2. If the clearance exceeds the service limit, measure the thickness of the shift fork fingers.

Standard: 7.4–7.5 mm (0.291–0.295 in)

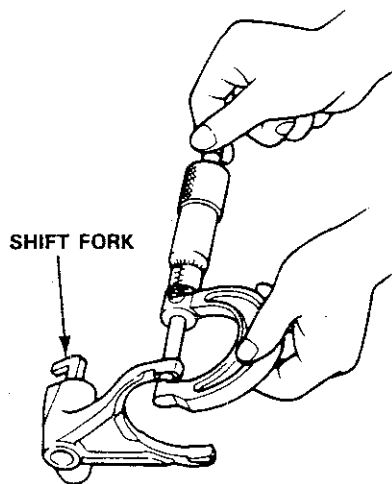

If the thickness of the shift fork fingers is less than the standard, replace the shift fork with a new one. If the thickness of the shift fork fingers is within the standard, replace the synchro sleeve with a new one.



3. Measure the clearance between the shift piece and shift fork shaft.

**Standard:** 0.2–0.5 mm (0.008–0.020 in)  
**Service Limit:** 0.8 mm (0.031 in)

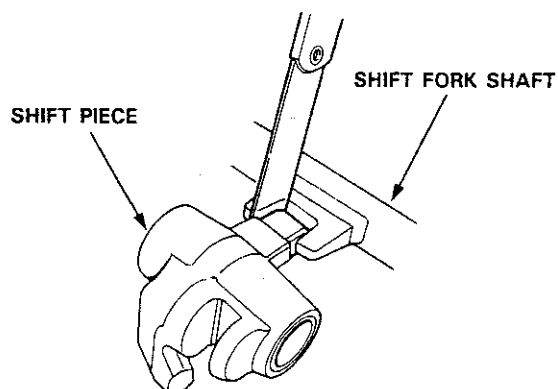

4. If the clearance exceeds the service limit, measure the width of the shift piece.

**Standard:** 11.9–12.0 mm (0.469–0.472 in)

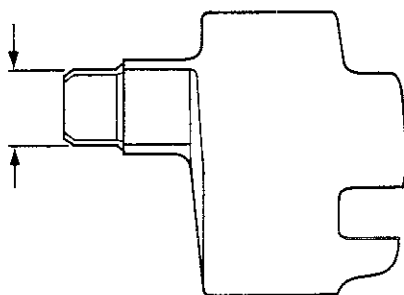

If the width of the shift piece is less than the standard, replace the shift piece with a new one.  
If the width is within the standard, replace the shift fork shaft with a new one.

# Shift Fork Assembly

## Disassembly/Reassembly

NOTE: Install the spring pins, so their grooves are 180° apart.

 Prior to reassembling, clean all the parts in solvent. Dry them and apply lubricant to any contact surfaces.

Disassembly: Remove with the 3 mm spring pin and 5 mm spring pin.

Reassembly: Install the 5 mm spring pin first, then install the 3 mm spring pin.

5TH/REVERSE SHIFT FORK SHAFT

3RD/4TH SHIFT FORK

5 x 22 mm SPRING PIN  
Replace.

3 x 22 mm SPRING PIN  
Replace.

5TH/REVERSE SHIFT FORK

3 x 22 mm SPRING PIN  
Replace

5 x 22 mm SPRING PIN  
Replace

5 x 22 mm SPRING PIN  
Replace.

1ST/2ND SHIFT FORK

PIN DRIVE, 5.0 mm  
07744-0010400  
PIN DRIVER, 3.0 mm  
07744-0010200

3RD/4TH SHIFT FORK SHAFT

1ST/2ND SHIFT FORK SHAFT

5TH/REVERSE SHIFT PIECE

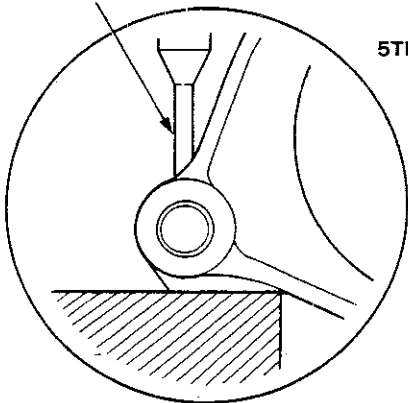



# Mainshaft Assembly

## Index

NOTE: The 3rd/4th and 5th synchro hubs are installed with a press.

 Prior to reassembling, clean all the parts in solvent, dry them and apply lubricant to any contact surfaces. The 3rd/4th and 5th synchro hubs, however, should be installed with a press before lubricating them.

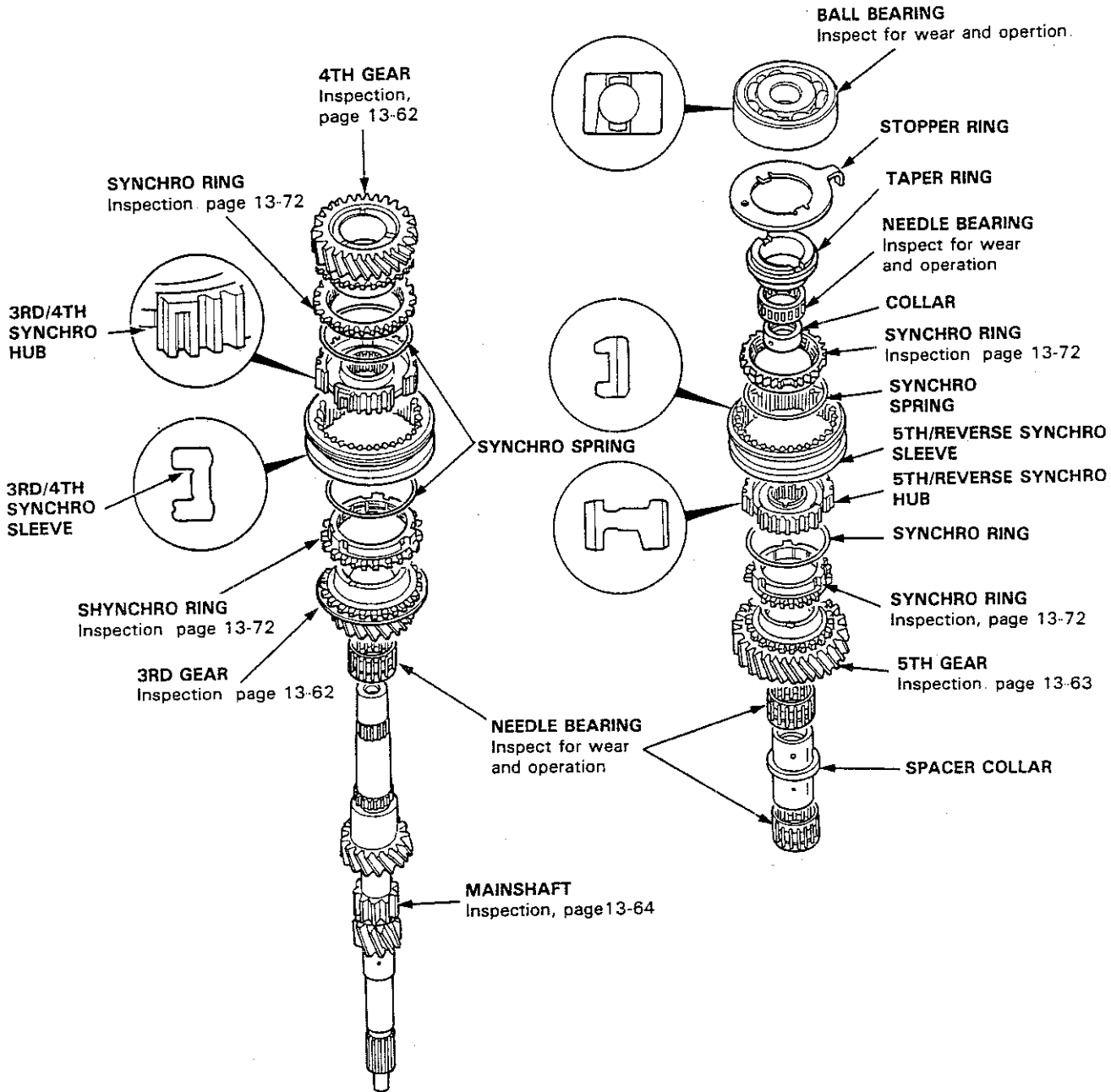

# Mainshaft Assembly

## Clearance Inspection

NOTE: If replacement is required, always replace the synchro sleeve and hub as a set

1. Measure the clearance between 2nd and 3rd gears.

**Standard:** 0.06–0.21 mm  
(0.002–0.008 in)  
**Service Limit:** 0.3 mm (0.012 in)

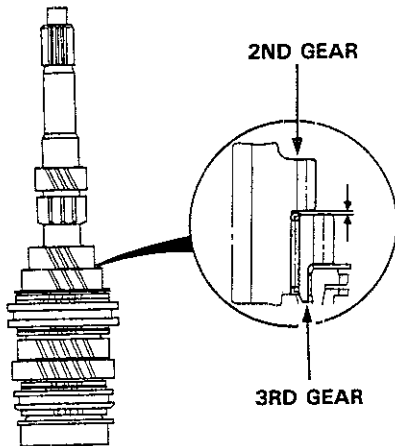

2. If the clearance exceeds the service limit, measure the thickness of 3rd gear.

**Standard:** 34.92–34.97 mm  
(1.375–1.377 in)  
**Service Limit:** 34.3 mm (1.350 in)

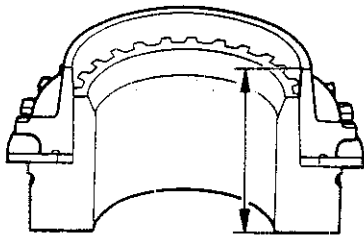

If the thickness of 3rd gear is less than the service limit, replace 3rd gear with a new one.  
If the thickness of 3rd gear is within the service limit, replace the 3rd/4th synchro hub with a new one.

3. Measure the clearance between 4th gear and the spacer collar

**Standard:** 0.06–0.21 mm  
(0.002–0.008 in)  
**Service Limit:** 0.3 mm (0.012 in)

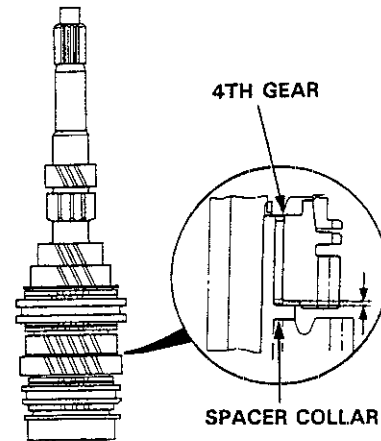

4. If the clearance exceeds the service limit, measure distance (A) on the spacer collar.

**Standard:** 26.03–26.08 mm  
(1.025–1.027 in)

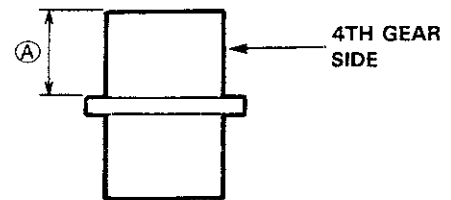

5. If distance (A) is less than the standard, replace the spacer collar with a new one.  
If distance (A) is within the standard, measure the thickness of 4th gear

**Standard:** 31.42–31.47 mm  
(1.237–1.239 in)  
**Service Limit:** 31.3 mm (1.232 in)

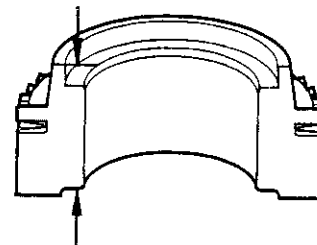

If the thickness of 4th gear is less than the service limit, replace 4th gear with a new one.  
If the thickness of 4th gear is within the service limit, replace the 3rd/4th synchro hub with a new one





6. Measure the clearance between 5th gear and the spacer collar

**Standard:** 0.06–0.21 mm  
(0.002–0.008 in)  
**Service Limit:** 0.3 mm (0.012 in)

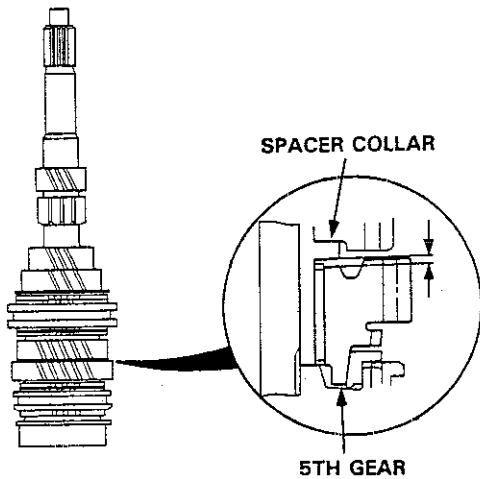

7. If the clearance exceeds the service limit, measure distance (B) on the spacer collar.

**Standard:** 26.03–26.08 mm  
(1.025–1.027 in)

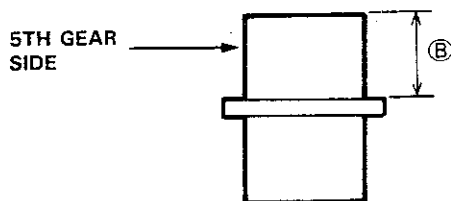

8. If distance (B) is less than the standard, replace the spacer collar with a new one.  
If distance (B) is within the standard, measure the thickness of 5th gear.

**Standard:** 31.42–31.47 mm  
(1.237–1.239 in)  
**Service Limit:** 31.3 mm (1.232 in)

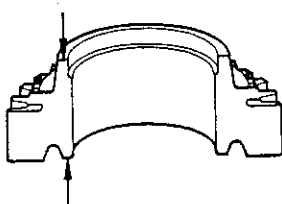

If the thickness of 5th gear is less than the service limit, replace 5th gear with a new one.  
If the thickness of 5th gear is within the service limit, replace the 5th/reverse synchro hub with a new one.

## Disassembly

**CAUTION:** Remove the synchro hubs using a press and steel blocks as shown. Use of a jaw-type puller can cause damage to the gear teeth

1. Remove the ball bearing using a bearing puller as shown.

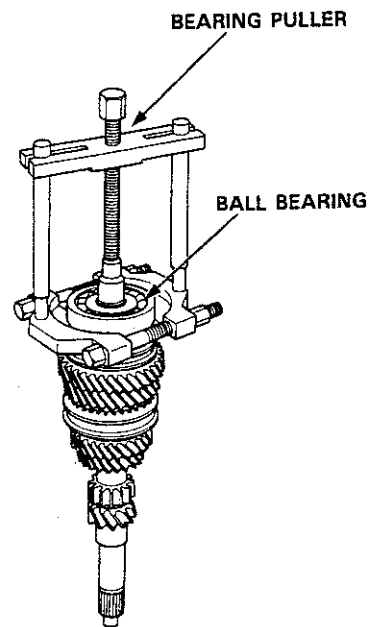

2. Support 5th gear on steel blocks as shown and press the shaft out of the 5th synchro hub.

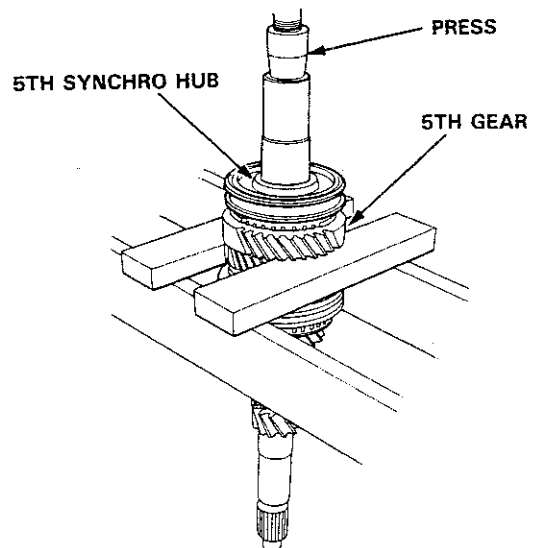

(cont'd)

# Mainshaft Assembly

## Disassembly (cont'd)

3. In the same manner as above, support the 3rd gear on steel blocks and press the shaft out of the 3rd/4th synchro hub

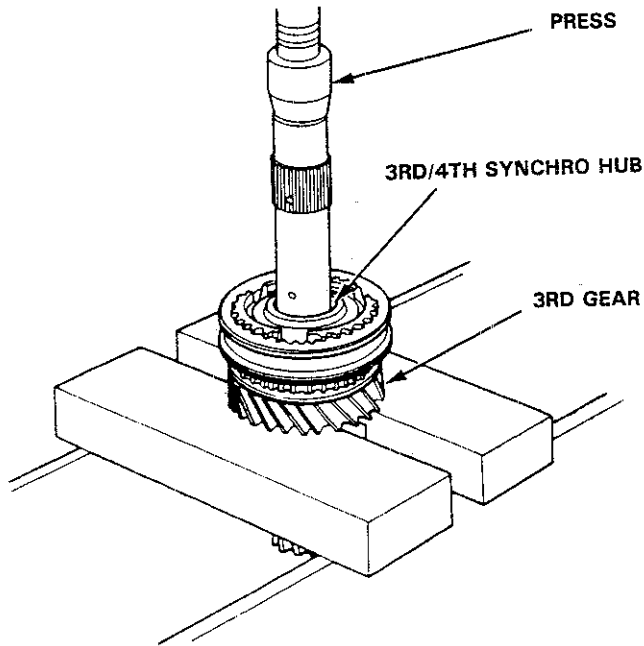

## Inspection

1. Inspect the surface and bearing surface for wear and damage, then measure the mainshaft at points A, B, and C.

<b>Standard:</b>	<b>A:</b> 27.977–27.990 mm (1.1015–1.1020 in)
	<b>B:</b> 37.984–38.000 mm (1.4954–1.4960 in)
	<b>C:</b> 27.987–28.000 mm (1.1018–1.1024 in)
<b>Service Limit:</b>	<b>A:</b> 27.930 mm (1.0996 in)
	<b>B:</b> 37.930 mm (1.4933 in)
	<b>C:</b> 27.940 mm (1.1000 in)

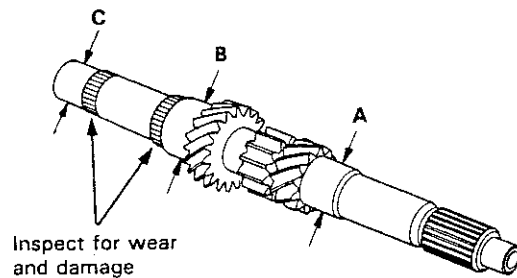

If any part of the mainshaft is less than the service limit, replace it with a new one.

2. Inspect for runout.

<b>Standard:</b>	0.02 mm (0.001 in)
<b>Service Limit:</b>	0.05 mm (0.002 in)

**NOTE:** Support the mainshaft at both ends as shown.

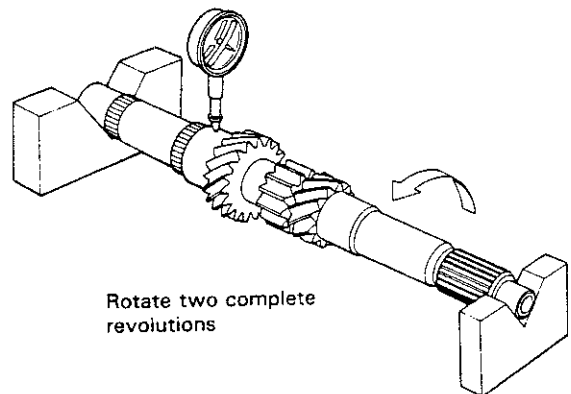

If the runout exceeds the service limit, replace the mainshaft with a new one



## Reassembly

### CAUTION:

- Press the 3rd/4th and 5th synchro hubs on the mainshaft without lubrication.
- When installing the 3rd/4th and 5th synchro hubs, support the shaft on steel blocks and install the synchro hubs using a press.
- Install the 3rd/4th and 5th synchro hubs with a maximum pressure of 2.000 kg.

NOTE: To assemble, see page 13-61.

1. Support 2nd gear on steel blocks as shown, then install the 3rd/4th synchro hub using the special tools and a press.

NOTE: Align the stoppers of the 3rd/4th synchro sleeve hub

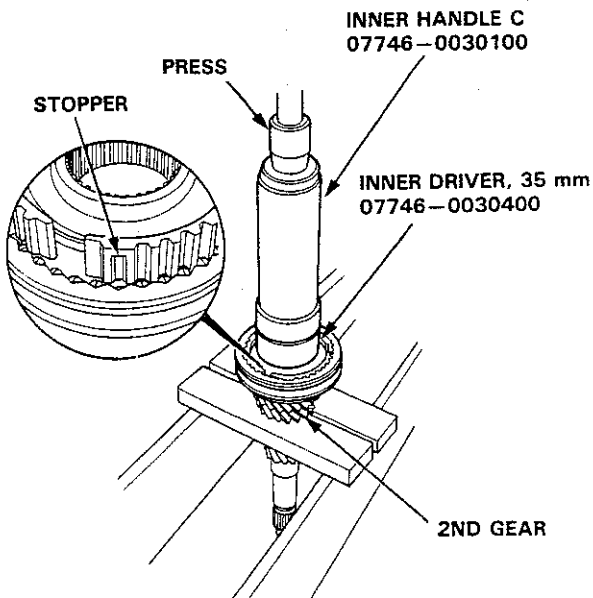

2. After installing, check the operation of the 3rd/4th synchro hub set.

3. Install the 5th/reverse synchro hub using the special tools and a press as shown

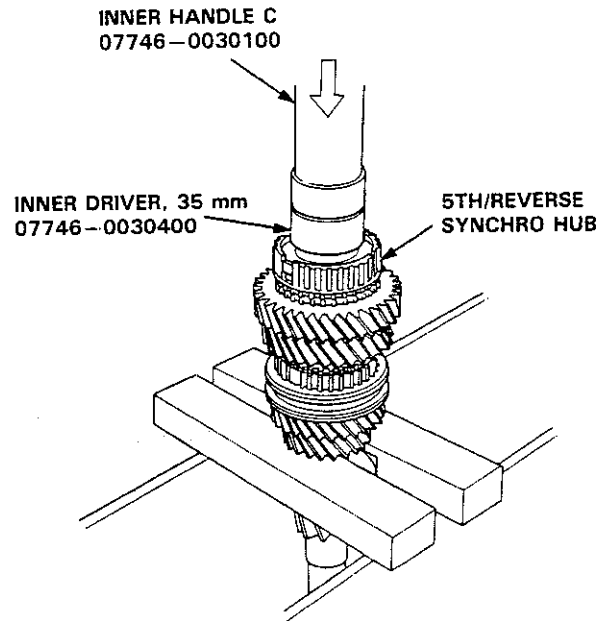

4. Install the ball bearing using the special tools and a press as shown.

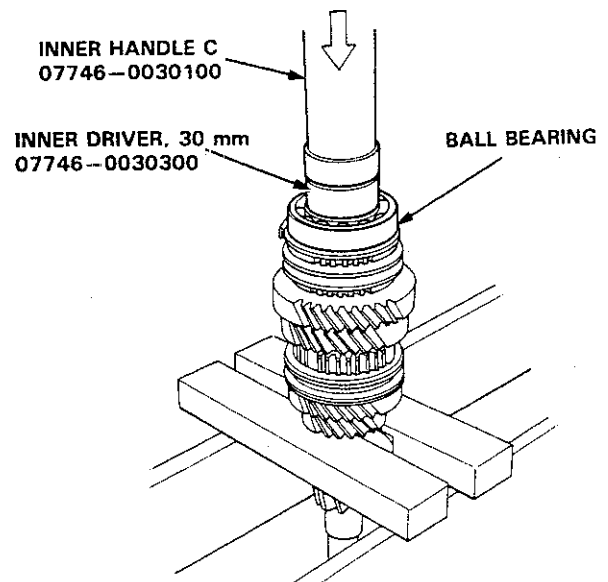

# Countershaft Assembly

## Index

NOTE: The 4th and 5th gears are installed with a press

 Prior to reassembling, clean all the parts in solvent, dry them and apply lubricant to any contact surfaces. The 4th and 5th gears, however, should be installed with a press before lubricating them.

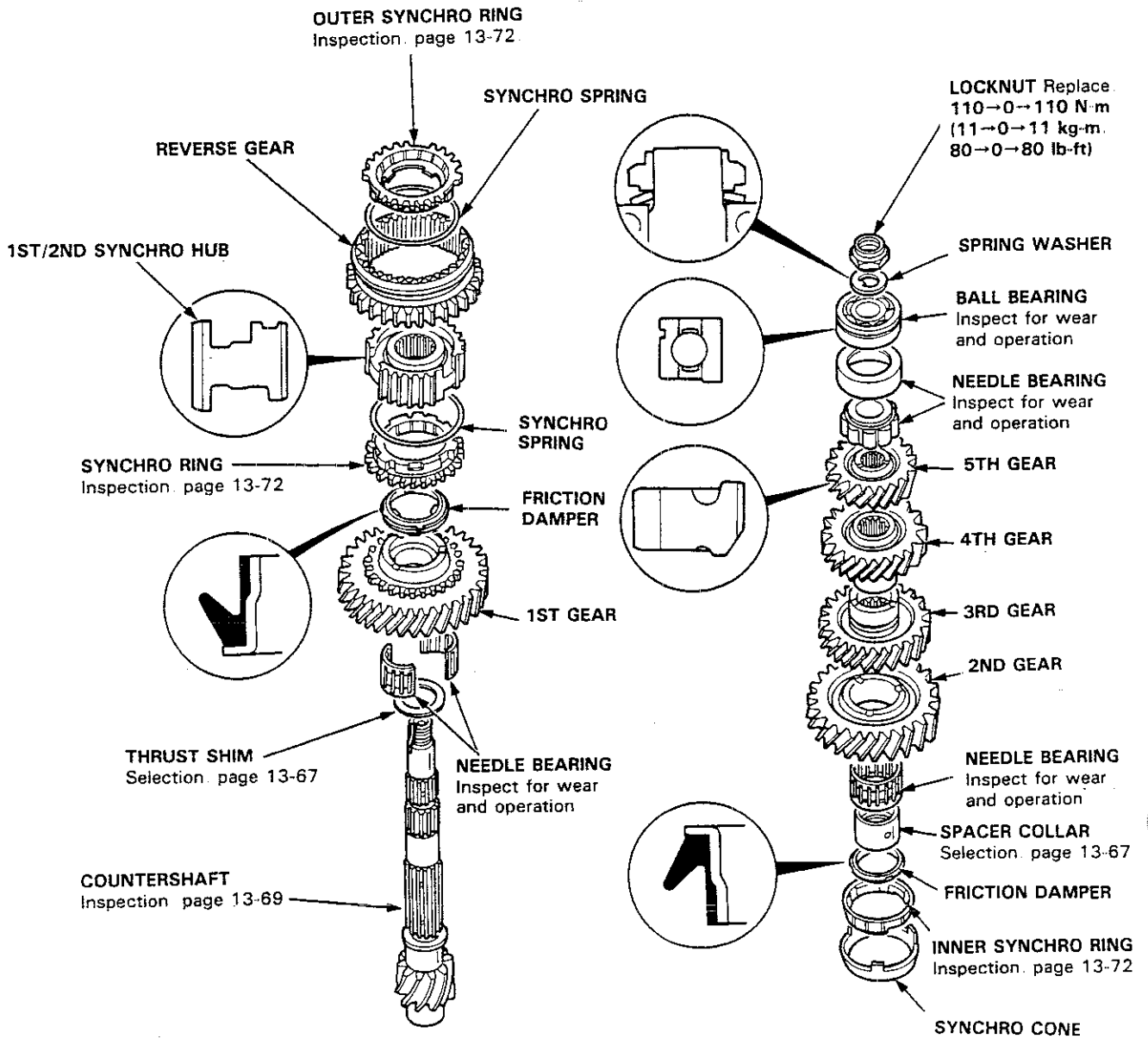



## Clearance Inspection

1. Measure the clearance between the 1st gear and thrust shim.

Standard: 0.04–0.12 mm  
(0.0016–0.0047 in)  
Service Limit: 0.18 mm (0.0071 in)

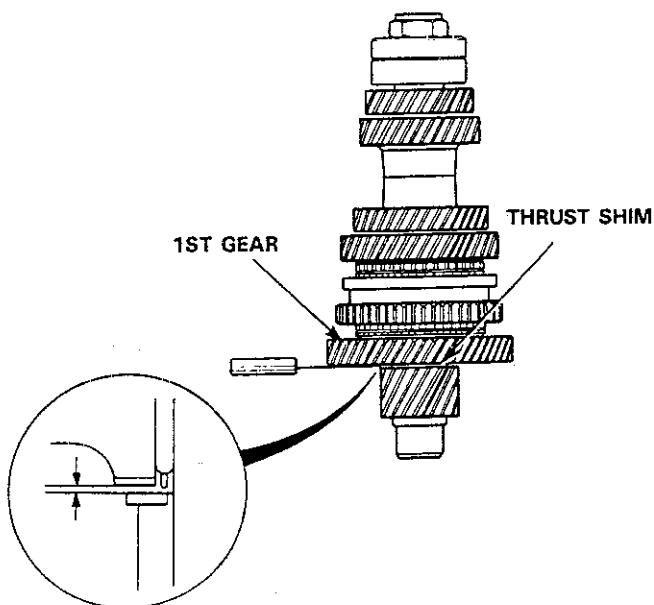

2. If the clearance exceeds the service limit, select the appropriate thrust shim for the correct clearance from the chart below.

	PART NUMBER	THICKNESS
A	23921-PK5-900	1.95 mm (0.0768 in)
B	23922-PK5-900	1.96 mm (0.0772 in)
C	23923-PK5-900	1.97 mm (0.0776 in)
D	23924-PK5-900	1.98 mm (0.0780 in)
E	23925-PK5-900	1.99 mm (0.0783 in)
F	23926-PK5-900	2.00 mm (0.0787 in)
G	23927-PK5-900	2.01 mm (0.0791 in)
H	23928-PK5-900	2.02 mm (0.0795 in)
I	23929-PK5-900	2.03 mm (0.0799 in)
J	23930-PK5-900	2.04 mm (0.0803 in)
K	23931-PK5-900	2.05 mm (0.0807 in)
L	23932-PK5-900	2.06 mm (0.0811 in)
M	23933-PK5-900	2.07 mm (0.0815 in)
N	23934-PK5-900	2.08 mm (0.0819 in)
O	23935-PK5-900	2.09 mm (0.0823 in)
P	23936-PK5-900	2.10 mm (0.0827 in)

3. Measure the clearance between the 2nd and 3rd gears.

Standard: 0.05–0.12 mm  
(0.0020–0.0047 in)  
Service Limit: 0.18 mm (0.0071 in)

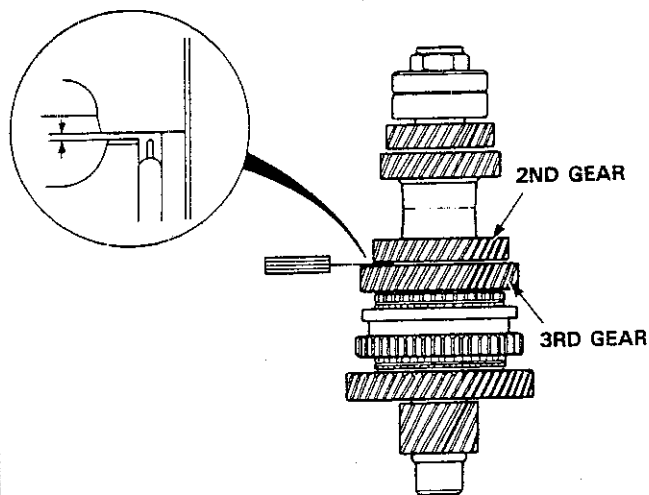

4. If the clearance exceeds the service limit, select the appropriate spacer collar for the correct clearance from the chart below.

	PART NUMBER	THICKNESS
A	23917-P21-010	29.02–29.04 mm (1.1425–1.1433 in)
B	23918-P21-010	29.07–29.09 mm (1.1445–1.1453 in)

# Countershaft Assembly

## Disassembly

**CAUTION:** Remove the gears using a press and steel blocks as shown. Use of a jow-tipe puller can damage the gear teeth.

1. Raise the locknut tab from the groove of the countershaft, then remove the locknut and the spring washer.

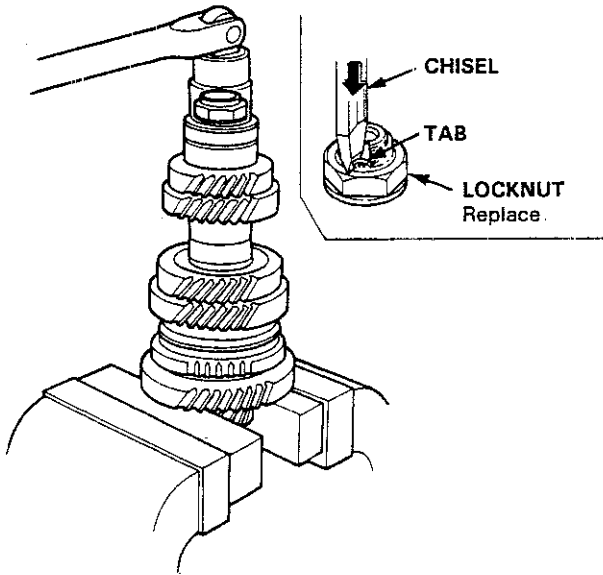

2. Remove the ball bearing using a bearing puller as shown

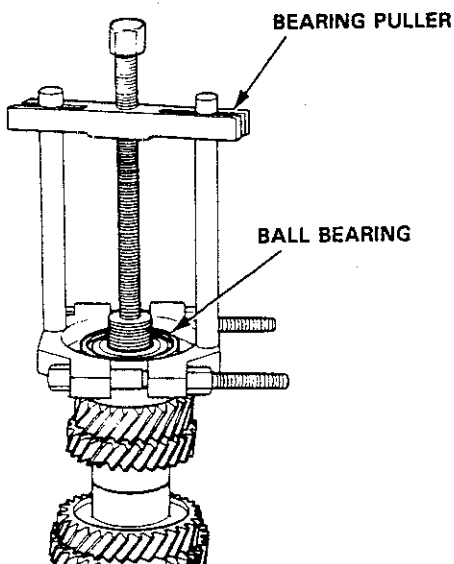

3. Remove the bearing outer race, then remove the needle bearing using a bearing puller as shown.

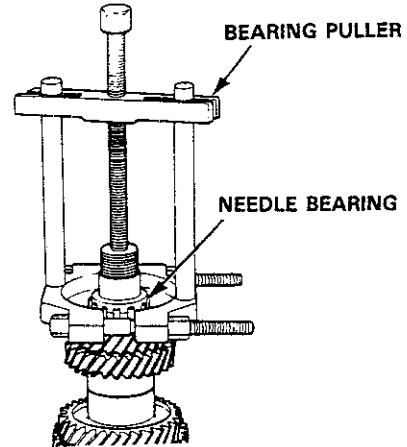

4. Support 4th gear on steel blocks as shown and press the countershaft out of 5th and 4th gears.

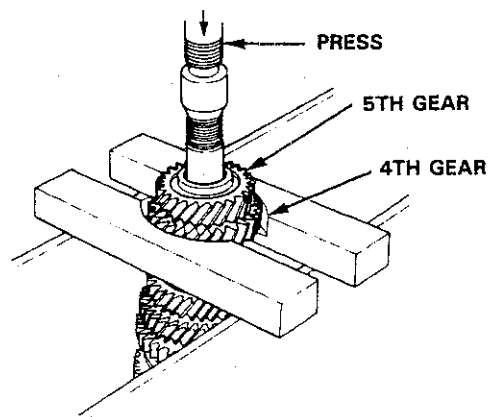



## Inspection

1. Inspect the surface and bearing surface for wear and damage, then measure the countershaft at points A, B, and C.

**Standard:**  
A: 24.980–24.993 mm  
(0.9835–1.1021 in)  
B: 36.984–37.000 mm  
(1.4561–1.4567 in)  
C: 33.000–33.015 mm  
(1.2992–1.2998 in)

**Service Limit:** A: 24.940 mm (0.9819 in)  
B: 36.930 mm (1.4539 in)  
C: 32.950 mm (1.2972 in)

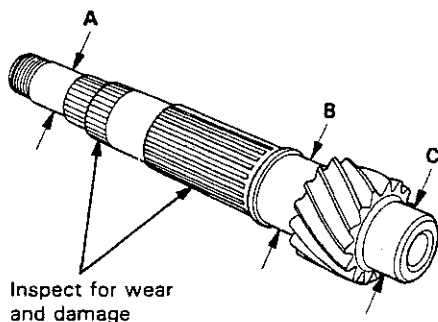

If any part of the countershaft is less than the service limit, replace it with a new one.

2. Inspect for runout.

**Standard:** 0.02 mm (0.001 in)  
**Service Limit:** 0.05 mm (0.002 in)

**NOTE:** Support the countershaft at both ends as shown.

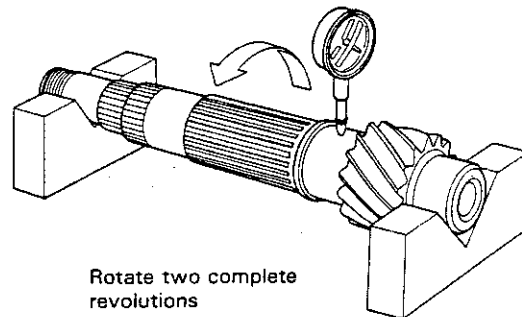

If the runout exceeds the service limit, replace the countershaft with a new one.

# Countershaft Assembly

## Reassembly

### CAUTION:

- Press the 4th and 5th gears on the countershaft without lubrication.
- When installing the 4th and 5th gears, support the shaft on steel blocks and install the gears using a press.
- Install the 4th and 5th gears with a maximum pressure of 2.600 kg.

NOTE: To assemble, see page 13-66

- 1 Install the thrust shim and needle bearing on the countershaft.

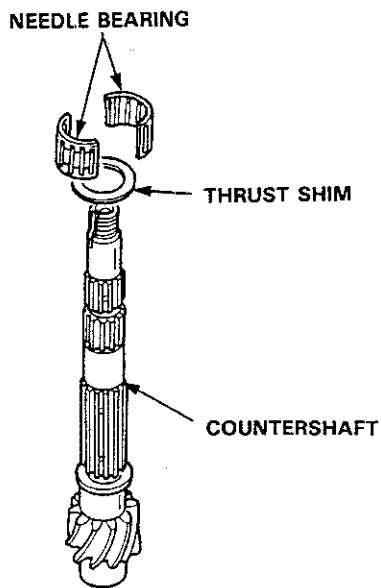

2. Assemble the parts below as shown

NOTE: Check that the fingers of the friction damper are securely set in the grooves of the 1st/2nd synchro hub.

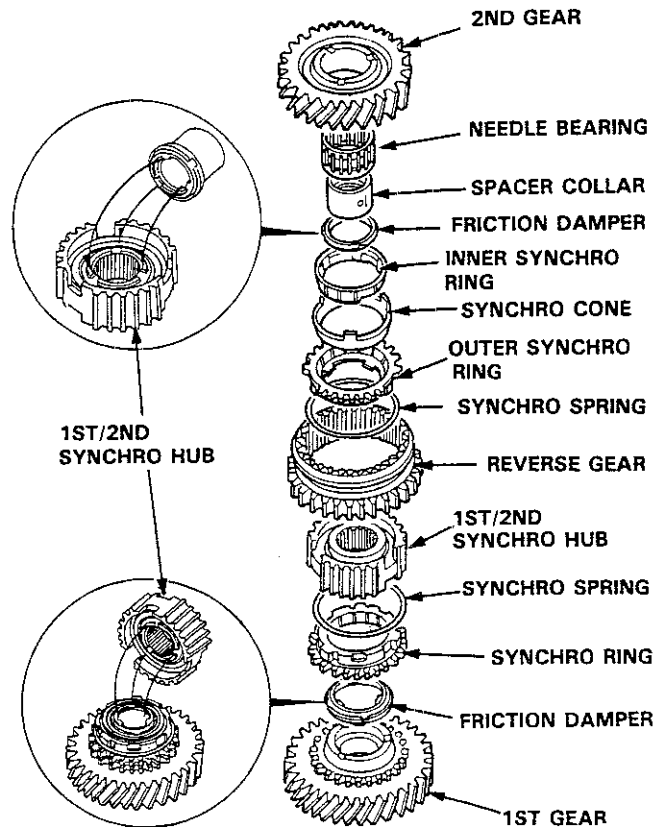

3. Place the parts assembled in step 2, then install the parts on the countershaft





4. Support the countershaft on a steel block as shown and install 4th gear using the special tools and a press.

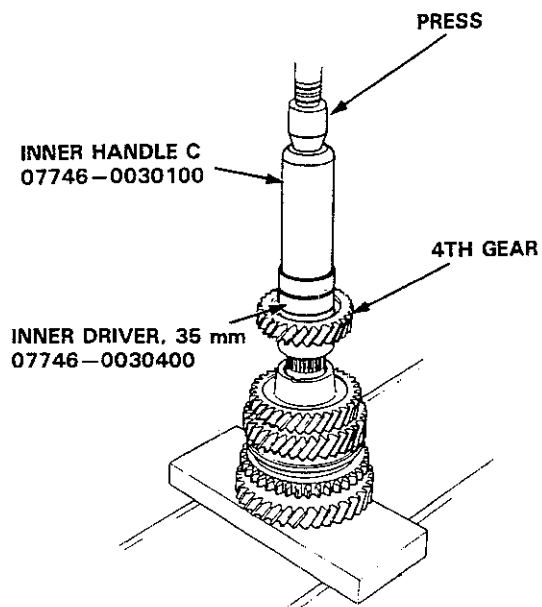

5. Install 5th gear using the special tools and a press as shown.

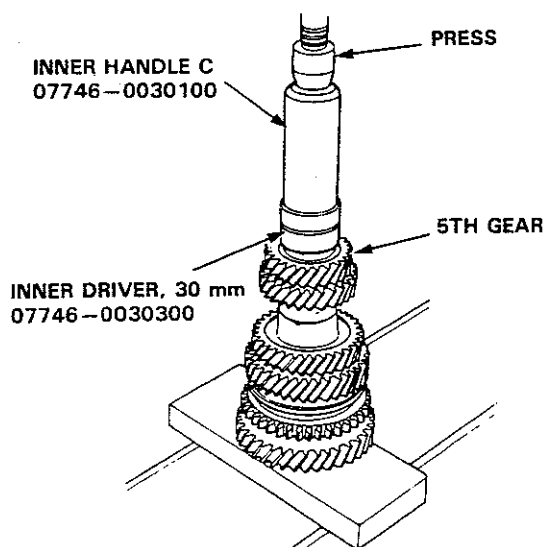

6. Install the needle bearing, then install the ball bearing using the special tools and a press as shown.

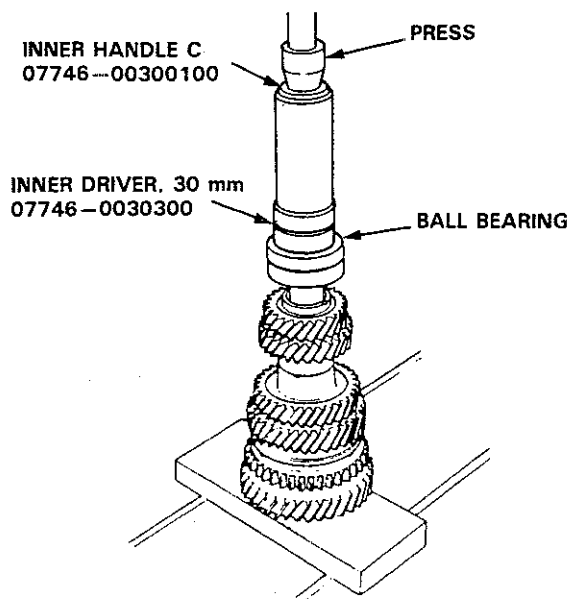

7. Install the spring washer, tighten the locknut, then stake the locknut tab into the groove.

**LOCK NUT**  
110→0→110 N·m  
(11→0→11 kg·m, 80 → 0 → 80 lb-ft)

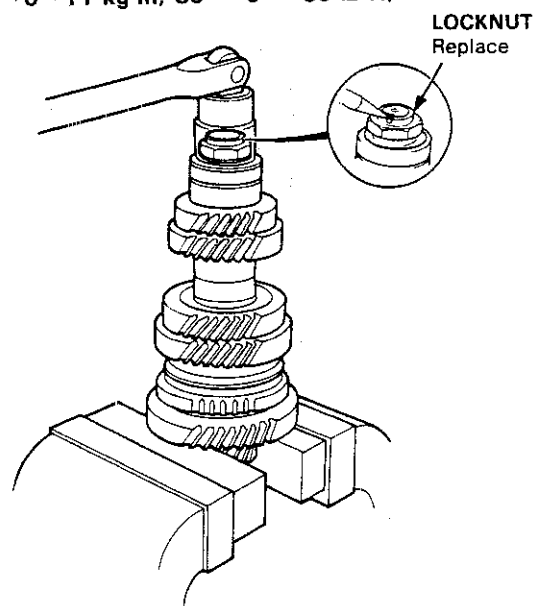

# Synchro Ring, Gear

## Inspection

1. Inspect the synchro ring and gear.

A : Inspect the inside of the synchro ring for wear.

B : Inspect the synchro sleeve teeth and matching teeth on the synchro ring for wear (rounded off).



C : Inspect the synchro sleeve teeth and matching teeth on the gear for wear (rounded off).



D : Inspect the gear hub thrust surface for wear.

E : Inspect the cone surface for wear and roughness.

F : Inspect the teeth on all gears for uneven wear, scoring, galling, and cracks

2. Coat the cone surface of the gear with oil and place the synchro ring on the matching gear. Rotate the ring, making sure that it does not slip

Measure the clearance between the ring and gear all the way around.

NOTE: Hold the ring against the gear evenly while measuring the clearance

### Ring-to-Gear Clearance

Standard: 0.85–1.1 mm  
(0.0335–0.0433 in)

Service Limit: 0.4 mm (0.0157 in)

### Double Cone Synchro-to-Gear Clearance

Standard:

A: (Outer Synchro Ring to Synchro Cone)  
0.5–1.0 mm (0.0197–0.0394 in)

B: (Synchro Cone to Gear)  
0.5–1.0 mm (0.0197–0.0394 in)

C: (Outer Synchro Ring to Gear)  
0.95–1.68 mm (0.0374–0.0661 in)

Service Limit:

A : 0.3 mm (0.0118 in)

B : 0.3 mm (0.0118 in)

C : 0.6 mm (0.0236 in)

If the clearance less than the service limit, replace the synchro ring and synchro cone

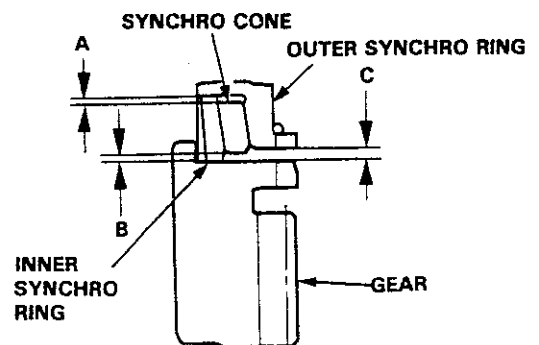
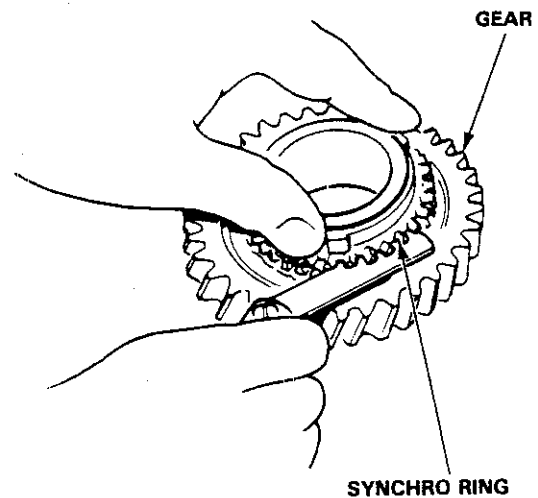
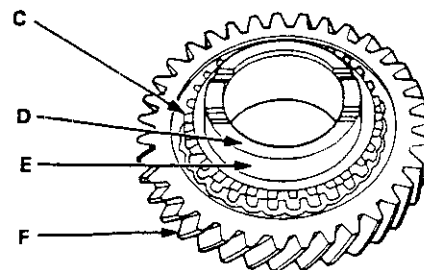
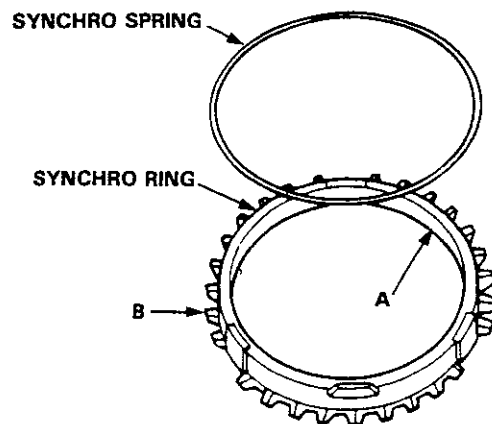



# Synchro Sleeve, Synchro Hub

## Inspection

1. Inspect gear teeth on all synchro hubs and sleeves for rounded off corners, which indicate wear.
2. Install each hub in its mating sleeve and check for freedom of movement.

NOTE: If replacement is required, always replace the synchro sleeve and hub as a set.

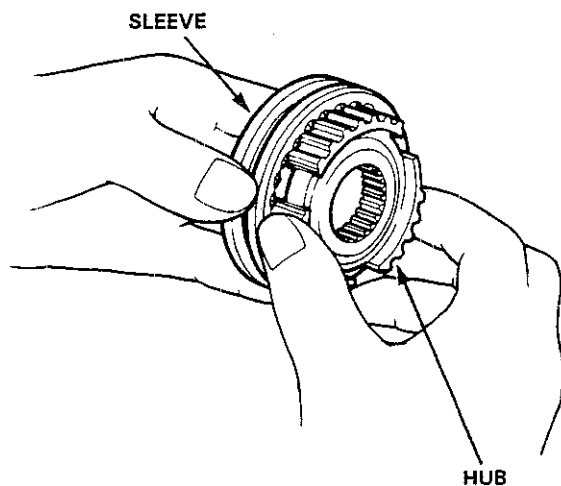

## Installation

Each synchro sleeve has three sets of longer teeth (120 degrees apart) that must be matched with the three sets of deeper grooves in the hub when assembled.

NOTE: If replacement is required, always replace the synchro sleeve and hub as a set.

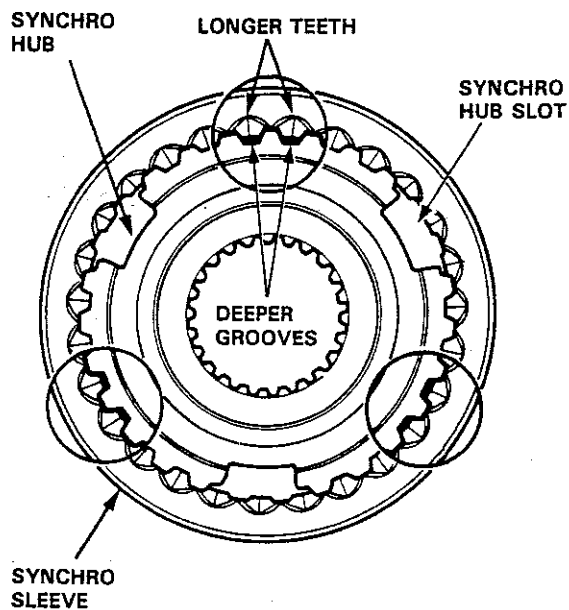

# Clutch Housing Bearing

## Replacement

### Mainshaft

- 1 Remove the ball bearing using the special tools.

ADJUSTABLE BEARING REMOVER SET  
07JAC-PH80000

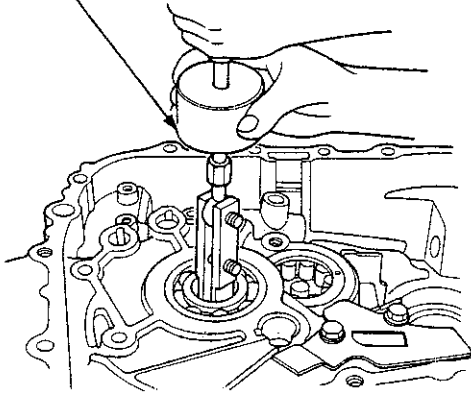

- 2 Remove the oil seal from the clutch housing.

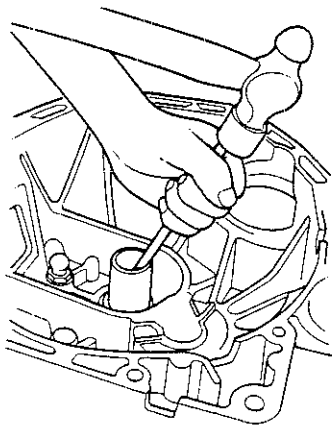

- 3 Drive the new oil seal into the clutch housing using the special tools.

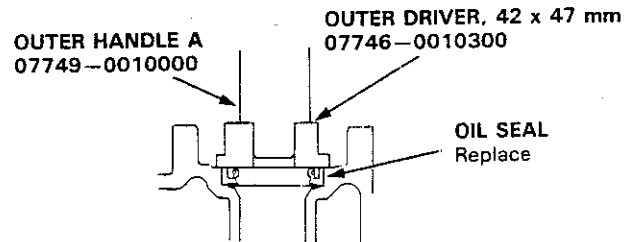
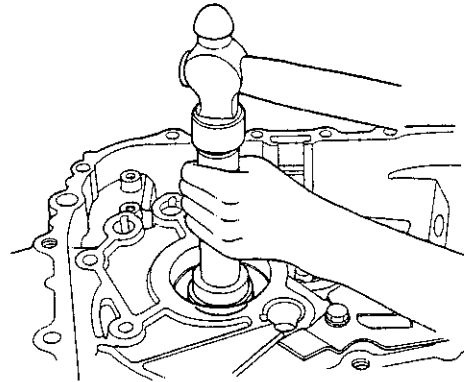

- 4 Drive the ball bearing into the clutch housing using the special tools.

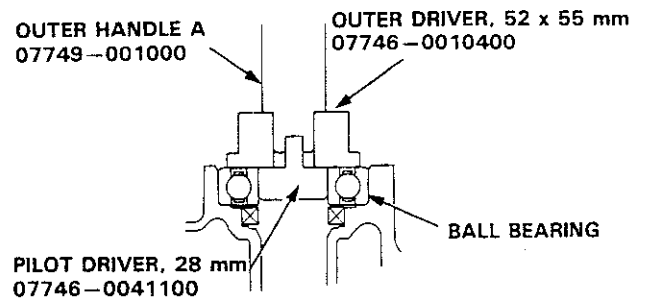
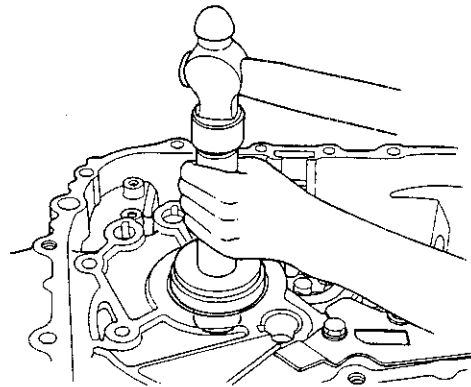



### Countershaft

1. Bend the tab on the lock washer down, then remove the bolt and bearing retainer plate

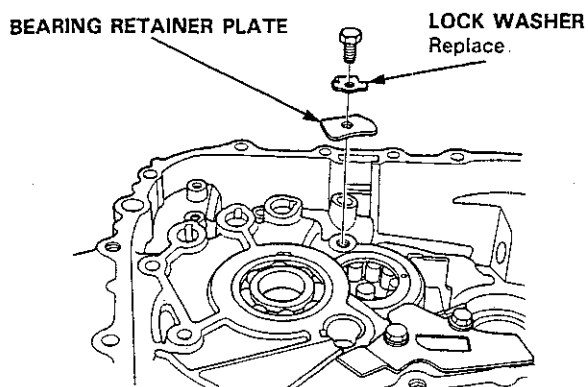

2. Remove the needle bearing using the special tools, and remove the oil guide plate

### ADJUSTABLE BEARING REMOVER SET 07JAC-PH80000

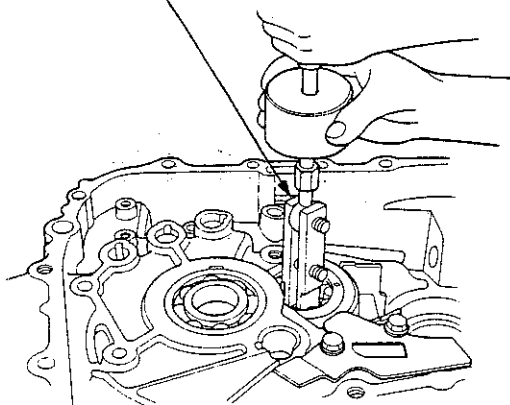

3. Install the oil guide plate, then drive the needle bearing into the clutch housing using the special tools.

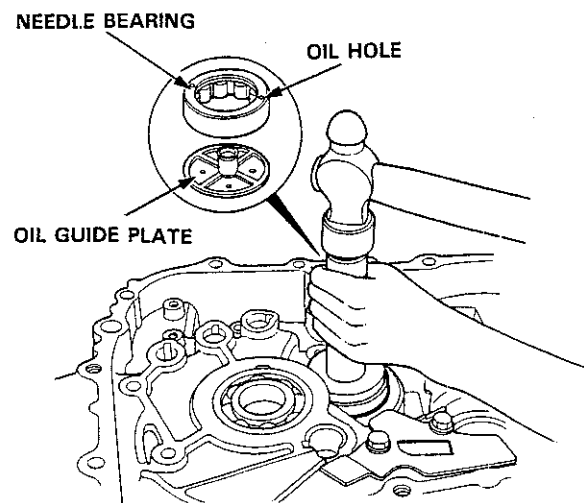

### OUTER HANDLE A 07749-0010000

### OUTER DRIVER, 52 x 55 mm 07746-0010400

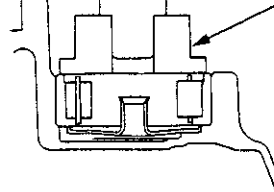

4. Install the bearing retainer plate and new lock washer, then bend the tab against the bolt head

8 x 10 mm  
15 N·m (1.5 kg·m, 11 lb·ft)

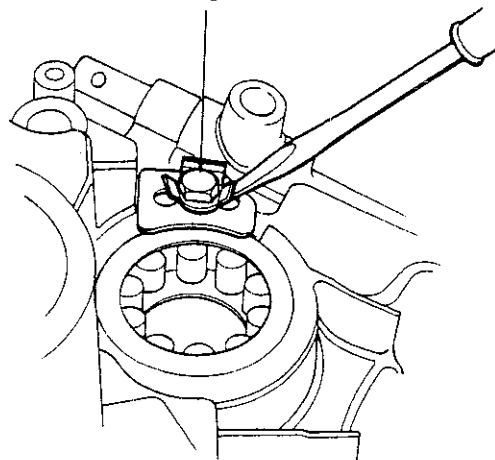

# Mainshaft Thrust Shim

## Adjustment

1. Remove the 72 mm thrust shim and oil guide plate from the transmission housing.

72 mm THRUST SHIM

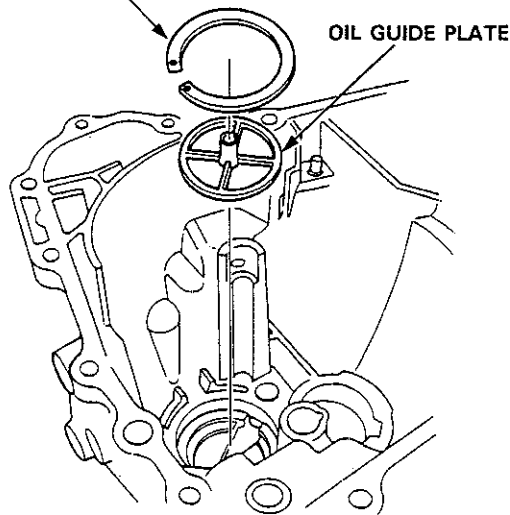

2. Install the 3rd/4th synchro hub, spacer collar, 5th synchro hub, collar, ball bearing, and 28 mm washer on the mainshaft. Install the assembly in the transmission housing.
3. Measure the distance (A) between the end of the transmission housing and 28 mm washer.

### NOTE:

- Use a straight edge and feeler gauge.
- Measure at three locations and average the readings.

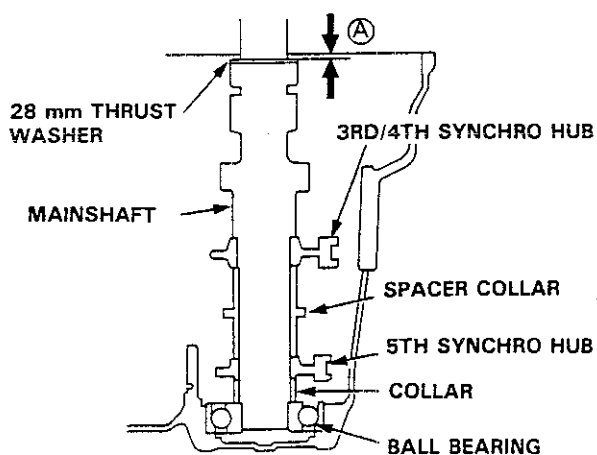

4. Measure the distance (B) between the surfaces of the clutch housing and bearing inner race.

### NOTE:

- Use a straight edge and feeler gauge.
- Measure at three locations and average the readings.

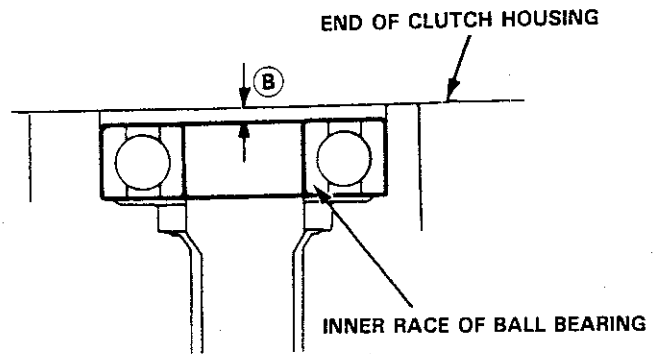

5. Select the proper shim on the basis of the following calculations:

NOTE: Do not use more than two shims.

(Basis Formula)

$$(A) + (B) - 1.00 = \text{shim thickness}$$

### Example of calculation:

$$\text{Distance (A) (2.05 mm) + Distance (B) (0.09 mm)} \\ = 2.14 \text{ mm. subtract the spring washer height} \\ (1.00 \text{ mm}) = \text{the required thrust shim (1.14 mm)}$$



### 72 mm Thrust Shim

	PART NUMBER	THICKNESS
A	23931-P21-000	0.60 mm (0.0236 in)
B	23932-P21-000	0.63 mm (0.0284 in)
C	23933-P21-000	0.66 mm (0.0260 in)
D	23934-P21-000	0.69 mm (0.0272 in)
E	23935-P21-000	0.72 mm (0.0283 in)
F	23936-P21-000	0.75 mm (0.0295 in)
G	23937-P21-000	0.78 mm (0.0307 in)
H	23938-P21-000	0.81 mm (0.0319 in)
I	23939-P21-000	0.84 mm (0.0331 in)
J	23940-P21-000	0.87 mm (0.0343 in)
K	23941-P21-000	0.90 mm (0.0354 in)
L	23942-P21-000	0.93 mm (0.0366 in)
M	23943-P21-000	0.96 mm (0.0378 in)
N	23944-P21-000	0.99 mm (0.0390 in)
O	23945-P21-000	1.02 mm (0.0402 in)
P	23946-P21-000	1.05 mm (0.0413 in)
Q	23947-P21-000	1.08 mm (0.0425 in)
R	23948-P21-000	1.11 mm (0.0437 in)
S	23949-P21-000	1.14 mm (0.0449 in)
T	23950-P21-000	1.17 mm (0.0461 in)
U	23951-P21-000	1.20 mm (0.0472 in)
V	23952-P21-000	1.23 mm (0.0484 in)
W	23953-P21-000	1.26 mm (0.0496 in)
X	23954-P21-000	1.29 mm (0.0508 in)
Y	23955-P21-000	1.32 mm (0.0520 in)
Z	23956-P21-000	1.35 mm (0.0531 in)
AA	23957-P21-000	1.38 mm (0.0543 in)
AB	23958-P21-000	1.41 mm (0.0555 in)
AC	23959-P21-000	1.44 mm (0.0567 in)
AD	23960-P21-000	1.47 mm (0.0579 in)
AE	23961-P21-000	1.50 mm (0.0591 in)
AF	23962-P21-000	1.53 mm (0.0602 in)
AG	23963-P21-000	1.56 mm (0.0614 in)
AH	23964-P21-000	1.59 mm (0.0626 in)
AI	23965-P21-000	1.62 mm (0.0638 in)
AJ	23966-P21-000	1.65 mm (0.0650 in)
AK	23967-P21-000	1.68 mm (0.0661 in)
AL	23968-P21-000	1.71 mm (0.0673 in)
AM	23969-P21-000	1.74 mm (0.0685 in)
AN	23970-P21-000	1.77 mm (0.0697 in)
AO	23971-P21-000	1.80 mm (0.0709 in)

6. Check the thrust clearance in the manner described below.

**NOTE:**

- Clean the thrust washer, spring washer and shim thoroughly before installation.
- Install the thrust washer, spring washer and shim properly

- a. Install the shim selected in the transmission housing
- b. Install the thrust washer and spring washer in the mainshaft

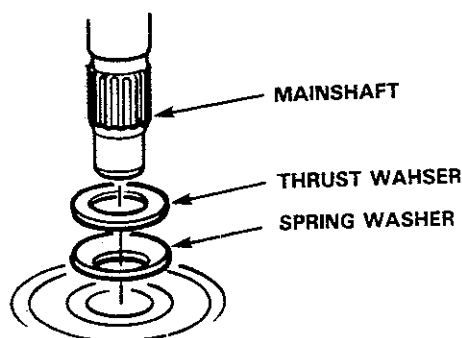

- c. Install the mainshaft in the clutch housing
- d. Place the transmission housing over the mainshaft and onto the clutch housing
- e. Tighten the clutch and transmission housings with several 8 mm bolts.
- f. Tap the mainshaft with a plastic hammer

7. Check the thrust clearance in the manner described below

**CAUTION:** Measurement should be made at room temperature.

- a. Slide the mainshaft base and the collar over the mainshaft

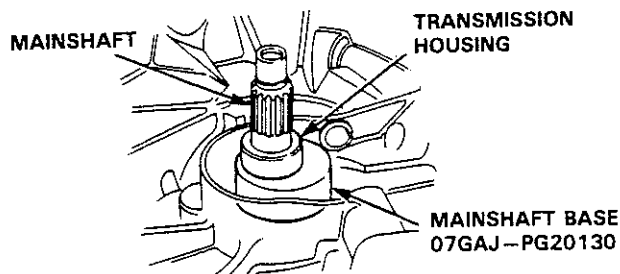

(cont'd)

# Mainshaft Thrust Shim

## Adjustment (cont'd)

b. Attach the mainshaft holder to the mainshaft as follows:

- Back-out the mainshaft holder bolt and loosen the two hex bolts.
- Fit the holder over the mainshaft so its lip is towards the transmission.
- Align the mainshaft holder's lip around the groove at the inside of the mainshaft splines, then tighten the hex bolts

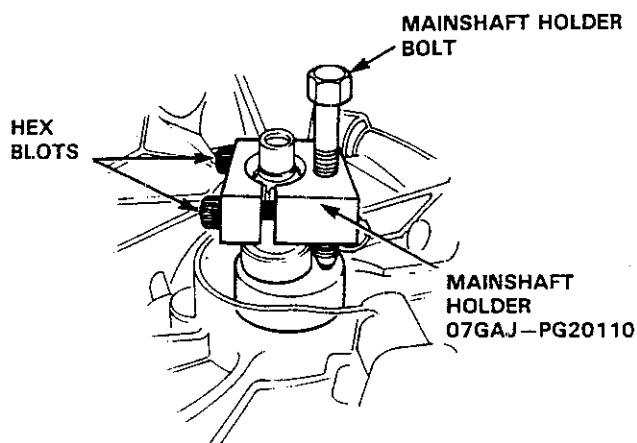

- c. Seat the mainshaft fully by tapping its end with a plastic hammer
- d. Thread the mainshaft holder bolt in until it just contacts the wide surface of the mainshaft base

e. Zero a dial gauge on the end of the mainshaft.

MAGNET STAND BASE  
07979-PJ40001

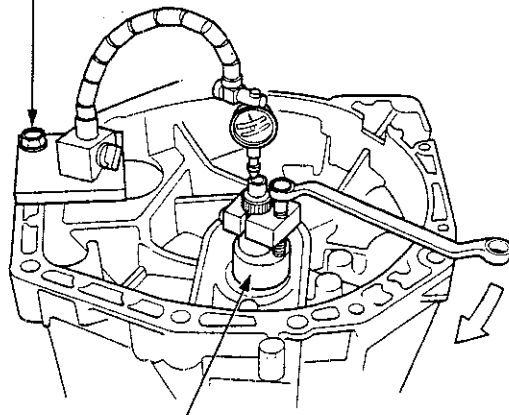

MAINSHAFT CLEARANCE INSPECTION TOOLS SET  
07GAJ-PG20102

- f. Turn the mainshaft holder bolt clockwise; stop turning when the dial gauge has reached its maximum movement. The reading on the dial gauge is the amount of mainshaft end play.

**CAUTION:** Turnig the shaft holder bolt more than 60 degrees after the needle of the dial gauge stops moving may damage the transmission.

- g. If the reading is within the standard, clearance is correct.  
It is not necessary to recheck the shim thickness.

Standard: 0.11–0.18 mm (0.004–0.007 in)





# Transmission

## Reassembly

1. Set the change piece on the clutch housing.
2. Insert the shift rod.
3. Install the steel ball, spring, and set bolt.
4. Install the change piece attaching bolt.

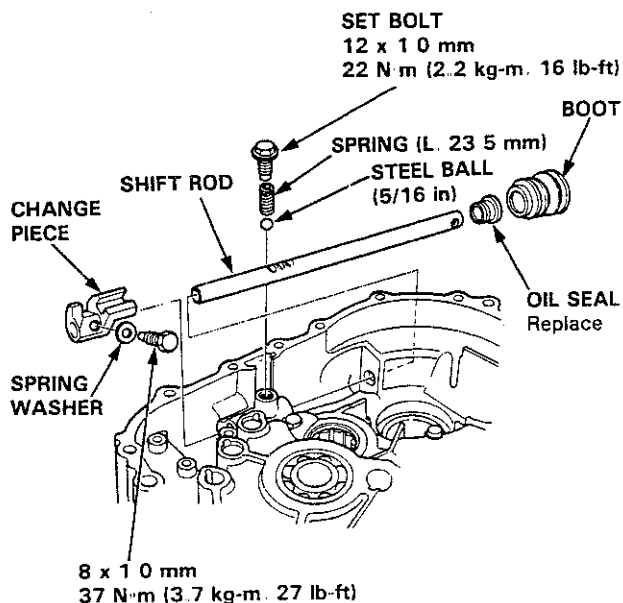

5. Install the chamber plate

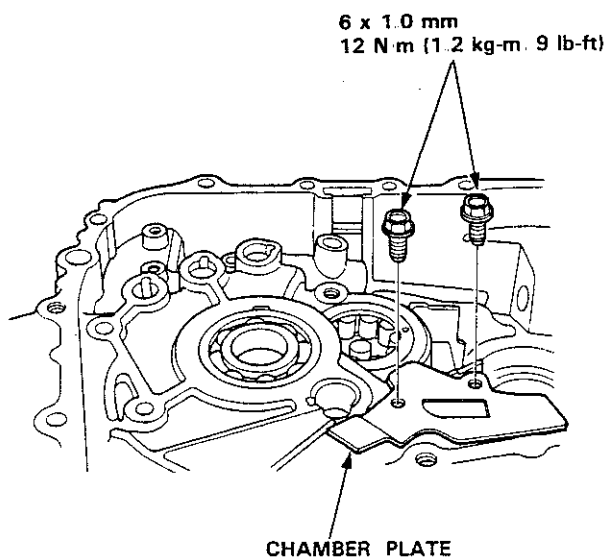

6. Install the differential assembly.

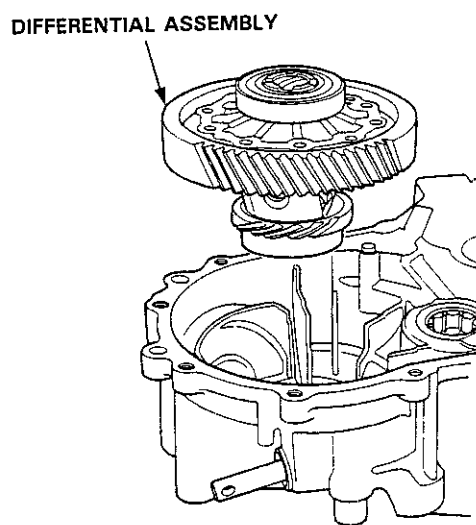

7. Set the 28 mm spring washer and washer
8. Install the mainshaft, countershaft, and shift fork assemblies

NOTE: Align the finger of the interlock and groove of the shift fork shaft.

### MAINSHAFT, COUNTERSHAFT, SHIFT FORK ASSEMBLES

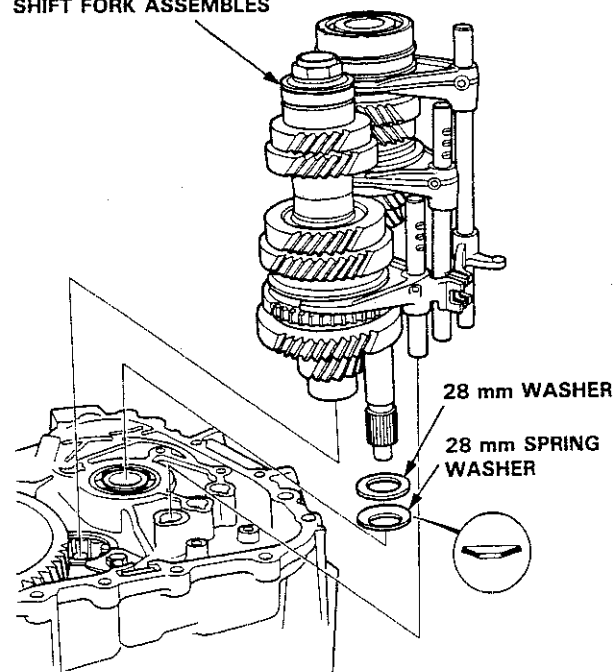

(cont'd)

# Transmission

## Reassembly (cont'd)

9. Install the change holder assembly.

6 x 1.0 mm  
15 N·m (1.5 kg·m,  
11 lb·ft)

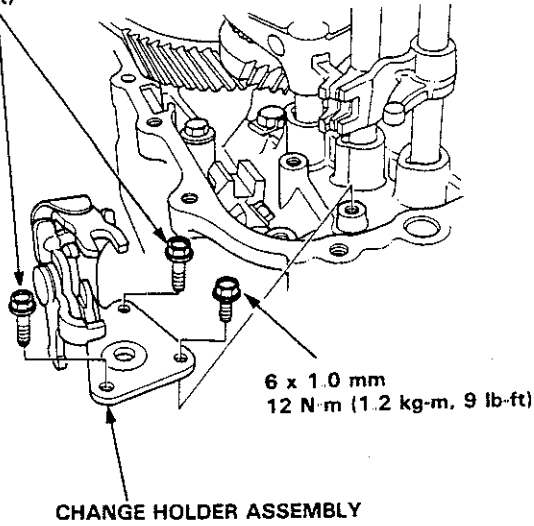

10. Install the shift piece and interlock, then install the shift piece shaft.

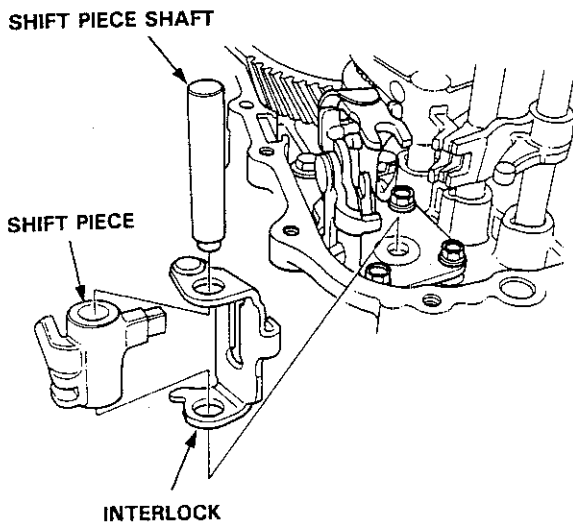

11. Measure the distance (A) with pressing the shift piece shaft. If it is not correct, check installation

Distance A: 11.9 – 12.3 mm (0.469 – 0.484 in)

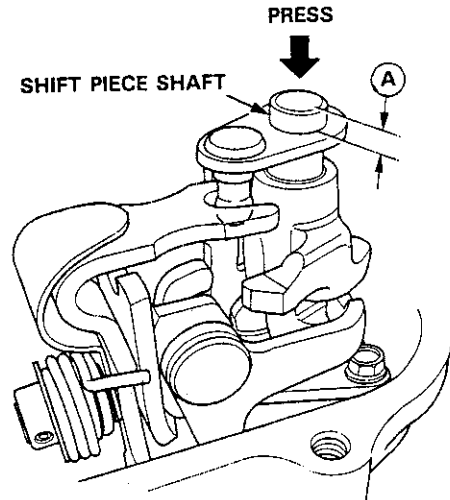

12. Shift the 3rd/4th shift fork to the 4th gear side then install the reverse idler gear and shaft.

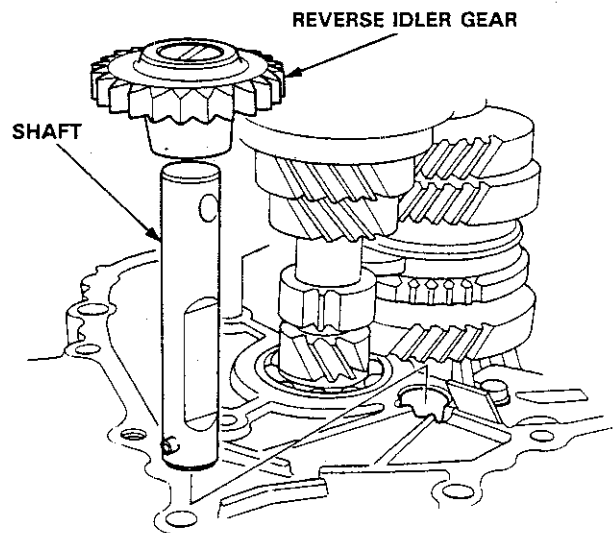



13. Install the reverse shift fork

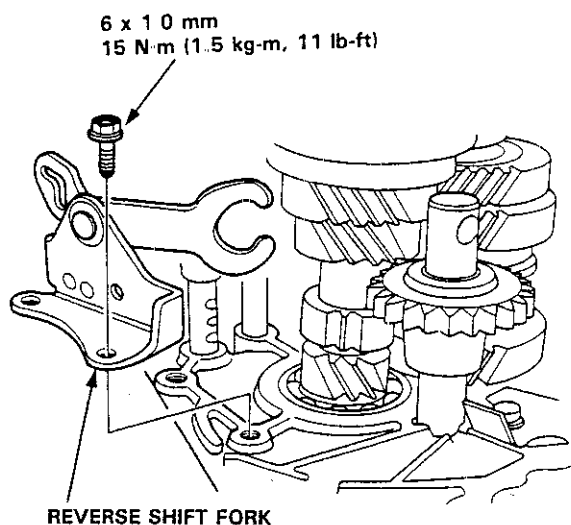

14. Install the oil guide plate and 72 mm thrust shim into the transmission housing.

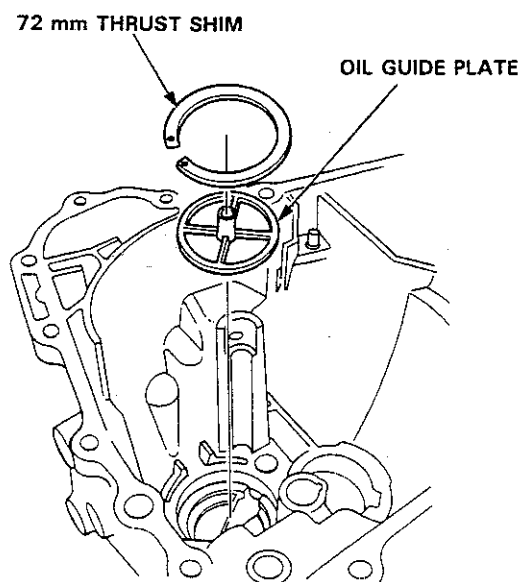

15. Install the oil gutter plate.

16. Bend the hook of the oil gutter plate, then install the 16 mm sealing bolt

NOTE: Apply liquid gasket (P/N OY740-99986) to the threads of the 16 mm sealing bolt.

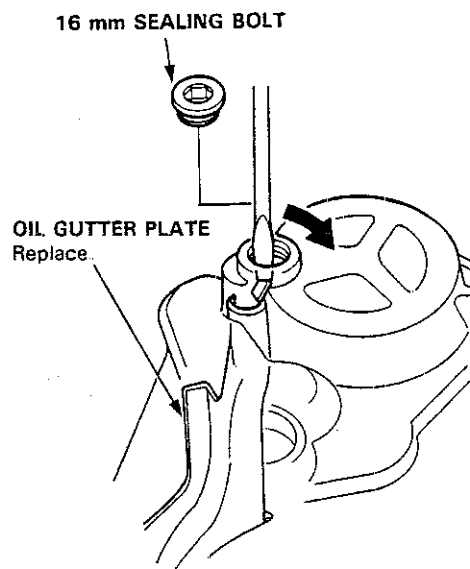

17. Apply liquid gasket to the transmission mating surface of the clutch housing.

NOTE: This transmission uses no gasket between the major housing; use Honda Genuine liquid gasket (P/N OY740-99986). Assemble the housing within 20 minutes after applying the liquid gasket and allow it to cure at least 30 minutes after assembly before filling it with oil

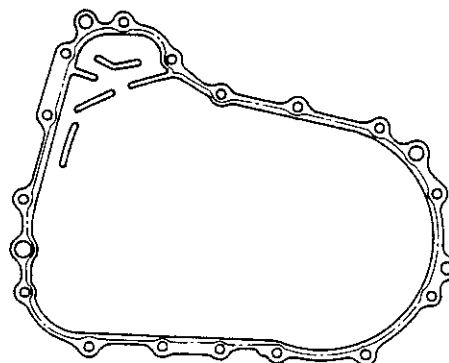

(cont'd)

# Transmission

## Reassembly (cont'd)

18. Install the 14 x 20 mm dowel pins.
19. Install the transmission housing by aligning the groove in the housing with the finger on the stopper ring.

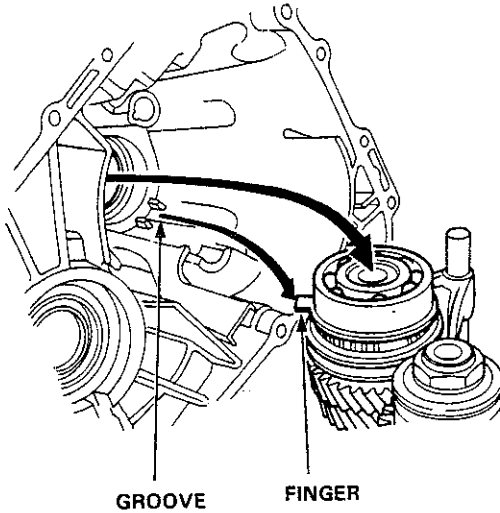

20. Lower the transmission housing with the snap ring expanded and set the snap ring in the groove of the countershaft bearing.

NOTE: Apply liquid gasket (P/N OY740-99986) to the threads of the 32 mm sealing bolt

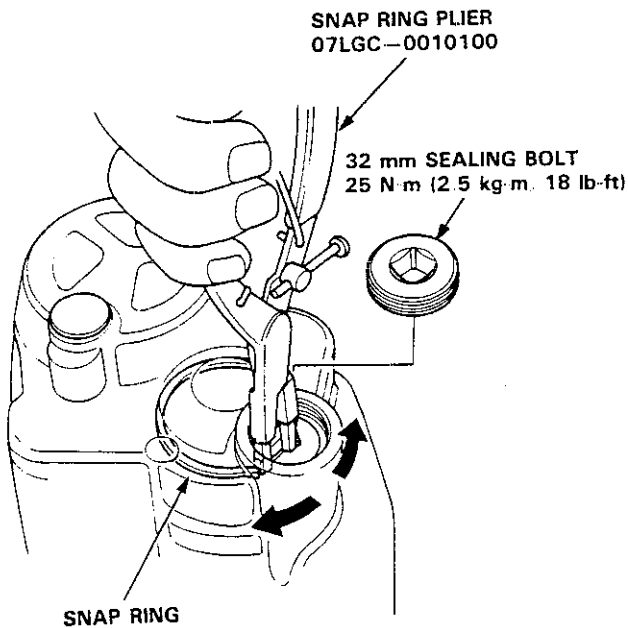

21. Check that the snap ring is securely seated in the groove of the countershaft bearing.

Dimension A as installed: 4.6-8.3 mm  
(0.181-0.327 in)

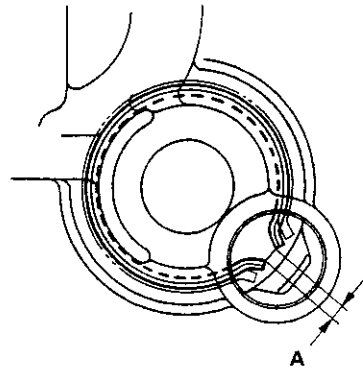

22. Tighten the transmission housing attaching bolts in the numbered sequence as shown

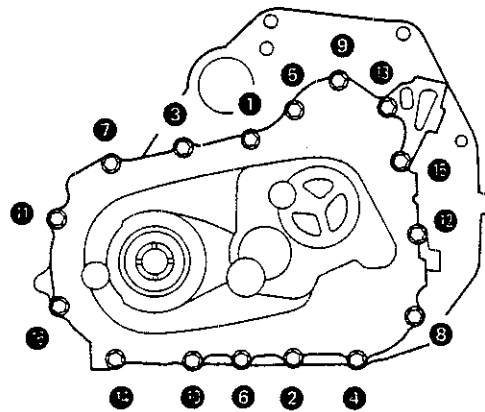

# Transmission Assembly



## Installation (cont'd)

23. Tighten the reverse idler gear shaft bolt.

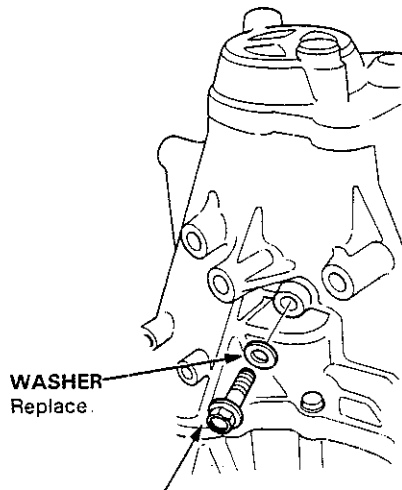

10 x 1 25 mm  
55 N·m (5.5 kg-m, 40 lb-ft)

24. Install the steel balls, springs, and set bolts.

25. Install the back-up light switch and transmission hanger B.

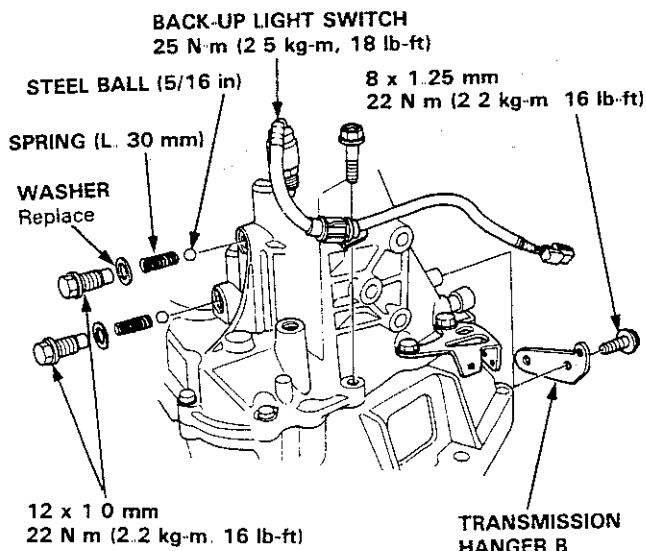

NOTE: Differences between the S20 model MT and Y21 model MT are covered on this page. Refer to page 13-37 for the information not covered on this page.

1. Install the transmission mounting bolts and transmission rear mount bolts.

12 x 1 25 mm  
60 N·m (6.0 kg-m, 43 lb-ft)

14 x 1 25 mm  
85 N·m (8.5 kg-m, 61 lb-ft)

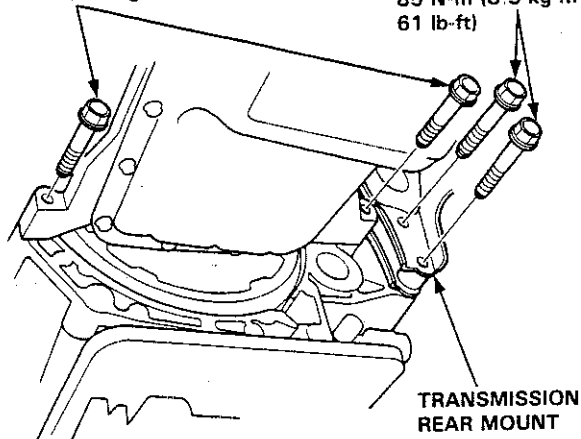

2. Install the change rod and change extension.

NOTE:

- Install the clip as shown
- Turn the boot hole down
- Make sure the boot is installed on the change rod

